

SPLC502B

132 x 65 Dot Matrix LCD Driver

MAR. 30, 2007

Version 1.0

Table of Contents

	<u>PAGE</u>
1. GENERAL DESCRIPTION	4
2. FEATURES	4
3. ORDERING INFORMATION	5
4. BLOCK DIAGRAM	5
5. SIGNAL DESCRIPTIONS	6
5.1. POWER SUPPLY PINS	6
5.2. LCD POWER SUPPLY CIRCUIT TERMINALS	6
5.3. SYSTEM BUS CONNECTION TERMINALS	7
5.4. LIQUID CRYSTAL DRIVE TERMINALS	9
5.5. TEST TERMINALS	9
6. FUNCTIONAL DESCRIPTIONS	10
6.1. THE MPU INTERFACE	10
6.2. THE CHIP SELECT	11
6.3. ACCESSING THE DISPLAY DATA RAM AND THE INTERNAL REGISTERS	11
6.4. THE BUSY FLAG	11
6.5. DISPLAY DATA RAM	12
6.6. THE DISPLAY DATA LATCH CIRCUIT	14
6.7. THE OSCILLATOR CIRCUIT	14
6.8. THE COMMON OUTPUT STATUS SELECT	14
6.9. DISPLAY TIMING GENERATOR CIRCUIT	14
6.10. THE LIQUID CRYSTAL DRIVER CIRCUITS	16
6.10. THE LIQUID CRYSTAL DRIVER CIRCUITS	16
6.11. THE POWER SUPPLY CIRCUITS	17
6.12. HIGH POWER MODE	20
6.13. THE INTERNAL POWER SUPPLY SHUTDOWN COMMAND SEQUENCE	20
6.14. REFERENCE CIRCUIT EXAMPLES	21
6.15. THE RESET CIRCUIT	23
7. COMMANDS	23
7.1. DISPLAY ON/OFF	24
7.2. DISPLAY START LINE SET	24
7.3. PAGE ADDRESS SET	24
7.4. COLUMN ADDRESS SET	25
7.5. STATUS READ	25
7.6. DISPLAY DATA WRITE	26
7.7. DISPLAY DATA READ	26
7.8. ADC SELECT (SEGMENT DRIVER DIRECTION SELECT)	26
7.9. DISPLAY NORMAL/REVERSE	26
7.10. DISPLAY ALL POINTS ON/OFF	27
7.11. LCD BIAS SET	27
7.12. READ/MODIFY/WRITE	27
7.13. END	28
7.14. RESET	29

7.15. COMMON OUTPUT MODE SELECT	29
7.16. POWER CONTROLLER SET	29
7.17. V0 VOLTAGE REGULATOR INTERNAL RESISTOR RATIO SET	30
7.18. THE ELECTRONIC VOLUME (DOUBLE BYTE COMMAND).....	30
7.19. STATIC INDICATOR (DOUBLE BYTE COMMAND).....	31
7.20. PAGE BLINKING (DOUBLE BYTE COMMAND).....	31
7.21. SET DRIVING MODE (DOUBLE BYTE COMMAND).....	32
7.22. POWER SAVE (COMPOUND COMMAND).....	33
7.23. NOP	34
7.24. TEST	34
7.25. OSCILLATOR FREQUENCY SELECTION	34
7.26. TABLE 13 TABLE OF SPLC502B COMMANDS.....	35
8. COMMAND DESCRIPTION	37
8.1. INSTRUCTION SETUP: REFERENCE (REFERENCE).....	37
9. ELECTRICAL SPECIFICATIONS	39
9.1. ABSOLUTE MAXIMUM RATINGS	39
9.2. DC CHARACTERISTICS	39
9.3. DISPLAY PATTERN CHECKER.....	40
9.4. DISPLAY PATTERN CHECKER.....	40
9.5. TIMING CHARACTERISTICS.....	42
9.6. THE MPU INTERFACE (REFERENCE EXAMPLES).....	48
9.7. CONNECTIONS BETWEEN LCD DRIVERS (REFERENCE EXAMPLE).....	50
9.8. CONNECTIONS BETWEEN LCD DRIVERS (REFERENCE EXAMPLES).....	51
10. VLCD VOLTAGE (VOLTAGE BETWEEN V0 TO VSS) RELATIONSHIP OF V0 VOLTAGE REGULATOR INTERNAL RESISTOR RATIO REGISTER AND ELECTRONIC VOLUME CONTROL REGISTER.....	52
11. CHIP INFORMATION	53
11.1. PAD ASSIGNMENT.....	53
11.2. PAD DIMENSION	53
11.3. BUMP CHARACTERISTIC	53
11.4. PAD LOCATIONS	54
11.5. COG ALIGN KEY COORDINATE	57
12. DISCLAIMER.....	58
13. REVISION HISTORY	59

132 x 65 DOT MATRIX LCD DRIVER

1. GENERAL DESCRIPTION

The SPLC502B, a single-chip dot matrix liquid crystal display drivers, is specially designed to connect directly with a microprocessor bus. The 8-bit parallel or serial display data sent from the microprocessor is stored in the internal display data RAM. It generates a liquid crystal drive signal independent of the microprocessor. Since the SPLC502B contains a 65 X 132 bits of display data RAM, a 1-to-1 correspondence between the liquid crystal panel pixels and the internal RAM bits, it is able to enable displays with a high degree of flexibility. The SPLC502B contains 65 common output circuits, 132 segment output circuits and therefore, a single chip can drive a 65 X 132 dot display (capable of displaying 8 columns X 4 rows of a 16 X 16 dot kanji font). In addition, the capacity of the display can also be extended through the use of master/slave structures between chips. The chips can save a great amount of power because no external operating clock is required for the display data RAM to read and write operations. Since each chip is equipped internally with a low-power liquid crystal driver power supply, resistors for liquid crystal driver power voltage adjustment and a display clock CR oscillator circuit, the SPLC502B can be used for creating the lowest power display system with the fewest components for high performance portable devices.

2. FEATURES

- Provide Reduced Capacitor of Follower (V1 ~ V4) function
- Direct display of RAM data through the display data RAM.
 - '1': Non-illuminated.
 - '0': Illuminated.
- RAM capacity.
 - 65 X 132 = 8580 bits.
- Display driver circuits.
 - SPLC502B: 65 common outputs and 132 segment outputs.
- Static drive circuit equipped internally for indicators.
 - (1 system, with variable flashing speed.)

- These chips not designed for resistance to light or Resistance to radiation.
- High-speed 8-bit MPU interface (capability to be connected directly to the both the 80X86 series MPUs and the 68000 series MPUs)/Serial interface are supported.
- Wide range of operating temperatures.
- CMOS process
- CR oscillator circuit equipped internally (External clock can also be input).
- Abundant command functions
 - Display data Read/Write, display ON/OFF, Normal/Reverse display mode, page address set, display start line set, column address set, status read, display all points ON/OFF, LCD bias set, electronic volume, read/modify/write, segment driver direction select, power saver, static indicator, common output status select, V0 voltage regulation internal resistor ratio set. Booster ratio set
- Low-power liquid crystal display power supply circuit equipped internally.
 - Booster circuit (with Boost ratios 2X/3X/4X/5X/6X, where the step-up voltage reference power supply can be input externally).
 - High-accuracy voltage adjustment circuit (Thermal gradient -0.05%/°C).
 - V0 voltage regulator resistors equipped internally, V1 to V4 voltage divider resistors equipped internally, electronic volume function equipped internally, voltage follower.
- Driving Mode register provided for different size panel loading.
- Extremely low power consumption.
 - Low operating power when the built-in power supply is used
- Power supply
 - Operable on the low 1.8 voltage
 - Logic power supply VDD - VSS = 1.8V to 3.6V
 - Boost reference voltage: VDD2 - VSS = 1.8V to 3.6V
 - Liquid crystal drive power supply (VLCD):V0 - VSS = 4V to 12V

Product Name	Duty	Bias	SED Dr	COM Dr	VREG Temperature Gradient	Shipping Forms
SPLC502B	1/65	1/9, 1/7	132	65	-0.05%/°C	Bare Chip with Gold Bump and TCP
	1/55	1/8, 1/6	132	55		
	1/49	1/8, 1/6	132	49		
	1/33	1/6, 1/5	132	33		

3. ORDERING INFORMATION

Product Number	Package Type
SPLC502B-C	Chip form with Gold Bump

4. BLOCK DIAGRAM

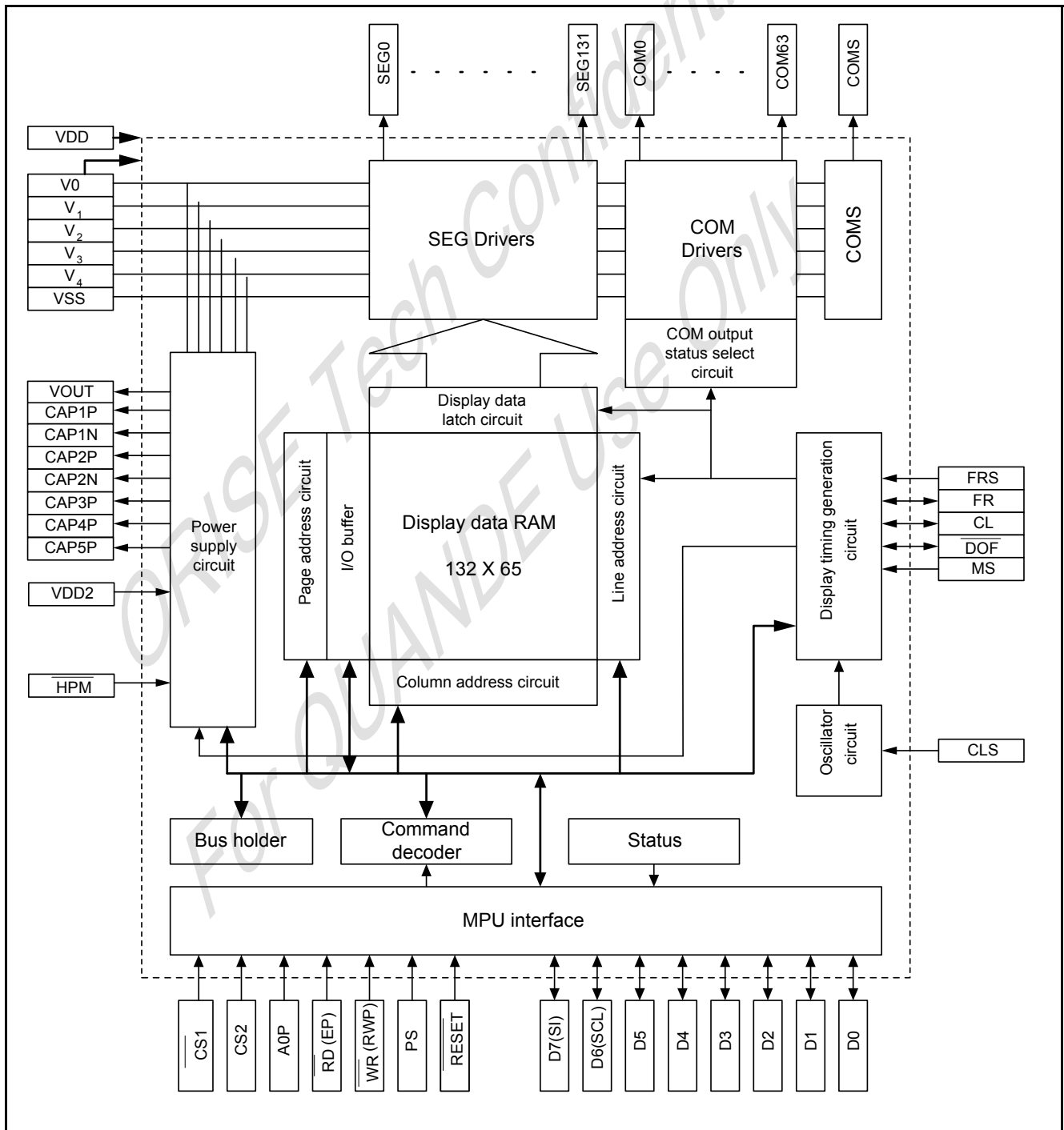

5. SIGNAL DESCRIPTIONS
5.1. Power Supply Pins

Mnemonic	PIN No.	Type	Description																									
VDD	9, 15 28 - 26 63 - 62 80	P	VDD Shared with MPU power supply terminal VCC																									
VSS	6 12 34 - 32 59 - 58 74	P	0V terminal connected to the system GND.																									
VDDA	31 - 29 61 - 60	P	A reference power supply for the step-up voltage circuit for the liquid crystal drive																									
VSSA	37 - 35 57 - 56	P	0V terminal connected to the system GND.																									
V ₀ , V ₁ , V ₂ , V ₃ , V ₄ ,	73 - 72 65 - 64 67 - 66 69 - 68 71 - 70	P	<p>A multi-level power supply for the liquid crystal drive. The voltage applied is determined by the liquid crystal cell, and is changed through the use of a resistive voltage divider or through changing the impedance using an op. amp. Voltage levels are determined based on VDD, and must maintain the relative magnitudes shown below.</p> $V_0 \geq V_1 \geq V_2 \geq V_3 \geq V_4 \geq VSS$ <p>Master operation: When the power supply turns ON, the internal power supply circuits generate the V₁ to V₄ voltages shown below. The voltage settings are selected by the LCD bias command.</p> <table border="1"> <thead> <tr> <th></th> <th>1/65 DUTY</th> <th>1/55 DUTY</th> <th>1/49 DUTY</th> <th>1/33 DUTY</th> </tr> </thead> <tbody> <tr> <td>V1</td> <td>8/9*V₀, 6/7*V₀</td> <td>7/8*V₀, 5/6*V₀</td> <td>7/8*V₀, 5/6*V₀</td> <td>5/6*V₀, 4/5*V₀</td> </tr> <tr> <td>V2</td> <td>7/9*V₀, 5/7*V₀</td> <td>6/8*V₀, 4/6*V₀</td> <td>6/8*V₀, 4/6*V₀</td> <td>4/6*V₀, 3/5*V₀</td> </tr> <tr> <td>V3</td> <td>2/9*V₀, 2/7*V₀</td> <td>2/8*V₀, 2/6*V₀</td> <td>2/8*V₀, 2/6*V₀</td> <td>2/6*V₀, 2/5*V₀</td> </tr> <tr> <td>V4</td> <td>1/9*V₀, 1/7*V₀</td> <td>1/8*V₀, 1/6*V₀</td> <td>1/8*V₀, 1/6*V₀</td> <td>1/6*V₀, 1/5*V₀</td> </tr> </tbody> </table>		1/65 DUTY	1/55 DUTY	1/49 DUTY	1/33 DUTY	V1	8/9*V ₀ , 6/7*V ₀	7/8*V ₀ , 5/6*V ₀	7/8*V ₀ , 5/6*V ₀	5/6*V ₀ , 4/5*V ₀	V2	7/9*V ₀ , 5/7*V ₀	6/8*V ₀ , 4/6*V ₀	6/8*V ₀ , 4/6*V ₀	4/6*V ₀ , 3/5*V ₀	V3	2/9*V ₀ , 2/7*V ₀	2/8*V ₀ , 2/6*V ₀	2/8*V ₀ , 2/6*V ₀	2/6*V ₀ , 2/5*V ₀	V4	1/9*V ₀ , 1/7*V ₀	1/8*V ₀ , 1/6*V ₀	1/8*V ₀ , 1/6*V ₀	1/6*V ₀ , 1/5*V ₀
	1/65 DUTY	1/55 DUTY	1/49 DUTY	1/33 DUTY																								
V1	8/9*V ₀ , 6/7*V ₀	7/8*V ₀ , 5/6*V ₀	7/8*V ₀ , 5/6*V ₀	5/6*V ₀ , 4/5*V ₀																								
V2	7/9*V ₀ , 5/7*V ₀	6/8*V ₀ , 4/6*V ₀	6/8*V ₀ , 4/6*V ₀	4/6*V ₀ , 3/5*V ₀																								
V3	2/9*V ₀ , 2/7*V ₀	2/8*V ₀ , 2/6*V ₀	2/8*V ₀ , 2/6*V ₀	2/6*V ₀ , 2/5*V ₀																								
V4	1/9*V ₀ , 1/7*V ₀	1/8*V ₀ , 1/6*V ₀	1/8*V ₀ , 1/6*V ₀	1/6*V ₀ , 1/5*V ₀																								

P: Power Supply

5.2. LCD Power Supply Circuit Terminals

Mnemonic	PIN No.	Type	Description
CAP1P	49-48	O	DC/DC voltage converter. A capacitor is connected between this terminal and the CAP1N terminal. The step-up voltage relationships are shown in Fig.7
CAP1N	47-46	O	DC/DC voltage converter. A capacitor is connected between this terminal and the CAP1P/CAP3P/CAP5P terminal. The step-up voltage relationships are shown in Fig.7
CAP2P	51-50	O	DC/DC voltage converter. A capacitor is connected between this terminal and the CAP2N terminal. The step-up voltage relationships are shown in Fig.7
CAP2N	53-52	O	DC/DC voltage converter. A capacitor is connected between this terminal and the CAP2P/CAP4P terminal. The step-up voltage relationships are shown in Fig.7
CAP3P	45-44	O	DC/DC voltage converter. A capacitor is connected between this terminal and the CAP1N terminal.
CAP4P	41,54,55	O	DC/DC voltage converter. A capacitor is connected between this terminal and the CAP2N terminal. The step-up voltage relationships are shown in Fig.7
CAP5P	43-42	O	DC/DC voltage converter. A capacitor is connected between this terminal and the CAP1N terminal. The step-up voltage relationships are shown in Fig.7

Mnemonic	PIN No.	Type	Description
V _{OUT}	40-38	O	DC/DC voltage converter. A capacitor is connected between this terminal and VSS.

5.3. System Bus Connection Terminals

Mnemonic	PIN No.	Type	Description															
DB7 - 0 (SI) (SCL)	23-16	I/O	This is an 8-bit bi-directional data bus that connects to an 8-bit or 16-bit standard MPU data bus. When the serial interface is selected (PS = 'L'), DB7 serves as the serial data input terminal (SI) and DB6 serves as the serial clock input terminal (SCL). At the same time, DB5 - 0 are set to high impedance. When the chip select is inactive, DB0 to DB7 are set to high impedance.															
A0P	11	I	This is connected to the least significant bit of the normal MPU address bus, and it determines whether the data bits are data or a command. A0P = 'H': Indicates DB7 - 0 is display data. A0P = 'L': Indicates DB7 - 0 is control data.															
RESET	10	I	When RESET is set to 'L', the settings are initialized. The RESET signal level performs the reset operation.															
CS1 CS2	7 8	I	This is the chip select signal. When CS1 = 'L' and CS2 = 'H', the chip select becomes active, and data/command I/O is enabled.															
RD (EP)	14	I	When connected to an 8080 MPU, this is LOW active. This pin is connected to the RD signal of the 8080 MPU, and the SPLC502B data bus is in an output status when this signal is 'L'. When connected to a 6800 Series MPU, this is HIGH active. This is the 68000 Series MPU enable clock input terminal.															
WR (RWP)	13	I	When connected to an 8080 MPU, this is LOW active. This terminal connects to the 8080 MPU WR signal. The signals on the data bus are latched at the rising edge of the WR signal. When connected to a 6800 Series MPU: This is the read/write control signal input terminal. When RWP = 'H': Read. When RWP = 'L': Write.															
C86	77	I	This is the MPU interface switch terminal. C86 = 'H': 6800 Series MPU interface. C86 = 'L': 8080 MPU interface.															
PS	78	I	This is the parallel data input/serial data input switch terminal. PS = 'H': Parallel data input. PS = 'L': Serial data input. The following applies depending on the PS status: <table border="1" data-bbox="528 1632 1299 1765"> <thead> <tr> <th>PS</th> <th>Data/Command</th> <th>Data</th> <th>Read/Write</th> <th>Serial Clock</th> </tr> </thead> <tbody> <tr> <td>'H'</td> <td>A0P</td> <td>DB0 to DB7</td> <td>RD, WR</td> <td>SCL (DB6)</td> </tr> <tr> <td>'L'</td> <td>A0P</td> <td>SI(DB7)</td> <td>Write only</td> <td>SCL (DB6)</td> </tr> </tbody> </table> When PS = 'L', DB0 to DB5 are high impedance. DB0 to DB5 may be 'H', 'L' or Open. RD (EP) and WR (RWP) are fixed to either 'H' or 'L'. With serial data input, RAM display data reading is not supported.	PS	Data/Command	Data	Read/Write	Serial Clock	'H'	A0P	DB0 to DB7	RD, WR	SCL (DB6)	'L'	A0P	SI(DB7)	Write only	SCL (DB6)
PS	Data/Command	Data	Read/Write	Serial Clock														
'H'	A0P	DB0 to DB7	RD, WR	SCL (DB6)														
'L'	A0P	SI(DB7)	Write only	SCL (DB6)														
CLS	76	I	Terminal to select whether to enable or disable the display clock internal oscillator circuit. CLS = 'H': Internal oscillator circuit is enabled. CLS = 'L': Internal oscillator circuit is disabled (requires external input). When CLS = 'L', input the display clock through the CL terminal.															
FR	3	I/O	This is the liquid crystal alternating current signal I/O terminal.															

Mnemonic	PIN No.	Type	Description																																								
			MS = 'H': Output MS = 'L': Input When the SPLC502B chip is used in master/slave mode, the various FR terminals must be connected.																																								
MS	75	I	This terminal selects the master/slave operation for the SPLC502B chips. Master operation outputs the timing signals that are required for the LCD display, while slave operation inputs the timing signals required for the liquid crystal display, synchronizing the liquid crystal display system. MS = 'H': Master operation MS = 'L': Slave operation The following is true depending on the MS and CLS status: <table border="1" data-bbox="523 741 1264 983"> <thead> <tr> <th>MS</th> <th>CLS</th> <th>Oscillator Circuit</th> <th>Power Supply Circuit</th> <th>CL</th> <th>FR</th> <th>FRS</th> <th>DOF</th> </tr> </thead> <tbody> <tr> <td>'H'</td> <td>'H'</td> <td>Enabled</td> <td>Enabled</td> <td>Output</td> <td>Output</td> <td>Output</td> <td>Output</td> </tr> <tr> <td></td> <td>'L'</td> <td>Disabled</td> <td>Enabled</td> <td>Input</td> <td>Output</td> <td>Output</td> <td>Output</td> </tr> <tr> <td>'L'</td> <td>'H'</td> <td>Disabled</td> <td>Disabled</td> <td>Input</td> <td>Input</td> <td>Output</td> <td>Input</td> </tr> <tr> <td></td> <td>'L'</td> <td>Disabled</td> <td>Disabled</td> <td>Input</td> <td>Input</td> <td>Output</td> <td>Input</td> </tr> </tbody> </table>	MS	CLS	Oscillator Circuit	Power Supply Circuit	CL	FR	FRS	DOF	'H'	'H'	Enabled	Enabled	Output	Output	Output	Output		'L'	Disabled	Enabled	Input	Output	Output	Output	'L'	'H'	Disabled	Disabled	Input	Input	Output	Input		'L'	Disabled	Disabled	Input	Input	Output	Input
MS	CLS	Oscillator Circuit	Power Supply Circuit	CL	FR	FRS	DOF																																				
'H'	'H'	Enabled	Enabled	Output	Output	Output	Output																																				
	'L'	Disabled	Enabled	Input	Output	Output	Output																																				
'L'	'H'	Disabled	Disabled	Input	Input	Output	Input																																				
	'L'	Disabled	Disabled	Input	Input	Output	Input																																				
CL	4	I/O	This is the display clock input terminal The following is true depending on the MS and CLS status. <table border="1" data-bbox="523 1077 810 1272"> <thead> <tr> <th>MS</th> <th>CLS</th> <th>CL</th> </tr> </thead> <tbody> <tr> <td>'H'</td> <td>'H'</td> <td>Output</td> </tr> <tr> <td></td> <td>'L'</td> <td>Input</td> </tr> <tr> <td>'L'</td> <td>'H'</td> <td>Input</td> </tr> <tr> <td></td> <td>'L'</td> <td>Input</td> </tr> </tbody> </table> When the SPLC502B chips are used in master/slave mode, the various CL terminals must be connected.	MS	CLS	CL	'H'	'H'	Output		'L'	Input	'L'	'H'	Input		'L'	Input																									
MS	CLS	CL																																									
'H'	'H'	Output																																									
	'L'	Input																																									
'L'	'H'	Input																																									
	'L'	Input																																									
DOF	5	I/O	This is the liquid crystal display blanking control terminal. MS = 'H': Output MS = 'L': Input When the SPLC502B chip is used in master/slave mode, the various DOF terminals must be connected.																																								
FRS	2	O	This is the output terminal for the static drive. This terminal is only enabled when the static indicator display is ON when in master operation mode, and is used in conjunction with the FR terminal.																																								
HPM	79	I	This is the power control terminal for the power supply circuit for liquid crystal drive. HPM = 'H': Normal mode. HPM = 'L': High power mode. This pin is enabled only when the master operation mode is selected. It is fixed to either 'H' or 'L' when the slave operation mode is selected. The detailed application circuit can refer 5.14.																																								
DSEL1-0	25-24	I	These pins can provide duty selection. <table border="1" data-bbox="523 1872 1182 2029"> <thead> <tr> <th>DSEL1</th> <th>DSEL0</th> <th>DUTY RATIO</th> <th>BIAS</th> </tr> </thead> <tbody> <tr> <td>1</td> <td>1</td> <td>1/65</td> <td>1/9 or 1/7</td> </tr> <tr> <td>1</td> <td>0</td> <td>1/55</td> <td>1/8 or 1/6</td> </tr> <tr> <td>0</td> <td>1</td> <td>1/49</td> <td>1/8 or 1/6</td> </tr> <tr> <td>0</td> <td>0</td> <td>1/33</td> <td>1/6 Or 1/5</td> </tr> </tbody> </table>	DSEL1	DSEL0	DUTY RATIO	BIAS	1	1	1/65	1/9 or 1/7	1	0	1/55	1/8 or 1/6	0	1	1/49	1/8 or 1/6	0	0	1/33	1/6 Or 1/5																				
DSEL1	DSEL0	DUTY RATIO	BIAS																																								
1	1	1/65	1/9 or 1/7																																								
1	0	1/55	1/8 or 1/6																																								
0	1	1/49	1/8 or 1/6																																								
0	0	1/33	1/6 Or 1/5																																								

5.4. Liquid Crystal Drive terminals

Mnemonic	PIN No.	Type	Description																										
SEG131 - 0	258-127	O	<p>These are the liquid crystal segment drive outputs. Through a combination of the contents of the display RAM and with the FR signal, a single level is selected from V₀, V₂, V₃, and VSS.</p> <table border="1"> <thead> <tr> <th rowspan="2">RAM DATA</th> <th rowspan="2">FR</th> <th colspan="2">Output Voltage</th> </tr> <tr> <th>Normal Display</th> <th>Reverse Display</th> </tr> </thead> <tbody> <tr> <td>H</td> <td>H</td> <td>V₀</td> <td>V₂</td> </tr> <tr> <td>H</td> <td>L</td> <td>VSS</td> <td>V₃</td> </tr> <tr> <td>L</td> <td>H</td> <td>V₂</td> <td>V₀</td> </tr> <tr> <td>L</td> <td>L</td> <td>V₃</td> <td>VSS</td> </tr> <tr> <td>Power save</td> <td>-</td> <td colspan="2">VSS</td> </tr> </tbody> </table>	RAM DATA	FR	Output Voltage		Normal Display	Reverse Display	H	H	V ₀	V ₂	H	L	VSS	V ₃	L	H	V ₂	V ₀	L	L	V ₃	VSS	Power save	-	VSS	
RAM DATA	FR	Output Voltage																											
		Normal Display	Reverse Display																										
H	H	V ₀	V ₂																										
H	L	VSS	V ₃																										
L	H	V ₂	V ₀																										
L	L	V ₃	VSS																										
Power save	-	VSS																											
COM31 - 0 COM32-63	94-125 259-290	O	<p>These are the liquid crystal common drive outputs.</p> <table border="1"> <thead> <tr> <th>Part No.</th> <th>COM</th> </tr> </thead> <tbody> <tr> <td>SPLC502</td> <td>COM63 -0</td> </tr> </tbody> </table> <p>Through a combination of the contents of the scan data and with the FR signal, a single level is selected from V₀, V₁, V₄, and Vss.</p> <table border="1"> <thead> <tr> <th>Scan Data</th> <th>FR</th> <th>Output Voltage</th> </tr> </thead> <tbody> <tr> <td>H</td> <td>H</td> <td>VSS</td> </tr> <tr> <td>H</td> <td>L</td> <td>V₀</td> </tr> <tr> <td>L</td> <td>H</td> <td>V₁</td> </tr> <tr> <td>L</td> <td>L</td> <td>V₄</td> </tr> <tr> <td>Power Save</td> <td>-</td> <td>VSS</td> </tr> </tbody> </table>	Part No.	COM	SPLC502	COM63 -0	Scan Data	FR	Output Voltage	H	H	VSS	H	L	V ₀	L	H	V ₁	L	L	V ₄	Power Save	-	VSS				
Part No.	COM																												
SPLC502	COM63 -0																												
Scan Data	FR	Output Voltage																											
H	H	VSS																											
H	L	V ₀																											
L	H	V ₁																											
L	L	V ₄																											
Power Save	-	VSS																											
COMS	126, 291	O	<p>These are the COM output terminals for the indicator. Both terminals output the same signal. Leave these pins open if they are not used. When in master/slave mode, the same signal is output by both master and slave.</p>																										

5.5. Test Terminals

Mnemonic	PIN No.	Type	Description
TEST	1	I	This is terminal for IC chip testing only, please tie to VSS.
TEST5, TEST6	81,82	O	These are terminals for IC chip testing only.
DUMY1~DUMY11	83~93	I	These are terminals for IC chip testing only.

6. FUNCTIONAL DESCRIPTIONS

6.1. The MPU Interface

6.1.1. Selecting the interface type

For SPLC502B, data transfers are accomplished through an 8-bit bi-directional data bus (DB7 - 0) or through a serial data input (SI). By selecting the PS terminal polarity to the 'H' or 'L', it is possible

to select either parallel data input or serial data input as shown in Table 1.

Table 1

PS	$\overline{\text{CS1}}$	CS2	A0P	$\overline{\text{RD}}$	$\overline{\text{WR}}$	C86	DB7	DB6	DB5 - 0
H: Parallel Input	$\overline{\text{CS1}}$	CS2	A0P	$\overline{\text{RD}}$	$\overline{\text{WR}}$	C86	DB7	DB6	DB5 - 0
L: Serial Input	$\overline{\text{CS1}}$	CS2	A0P	-	-	-	SI	SCL	(HiZ)

'-' indicates fixed to either 'H' or to 'L'

6.1.2. The parallel interface

When the parallel interface is selected (PS = 'H'), it is possible to connect directly to either an 8080-system MPU or a 6800 Series

MPU (as shown in Table 2) by selecting the C86 terminal to either 'H' or 'L'.

Table 2

C86	$\overline{\text{CS1}}$	CS2	A0P	$\overline{\text{RD}}$	$\overline{\text{WR}}$	DB7 - 0
H: 6800 Series MPU Bus	$\overline{\text{CS1}}$	CS2	A0P	EP	RWP	DB7 - 0
L: 8080 MPU Bus	$\overline{\text{CS1}}$	CS2	A0P	$\overline{\text{RD}}$	$\overline{\text{WR}}$	DB7 - 0

Data bus signals are recognized by a combination of A0P, $\overline{\text{RD}}$ (EP), $\overline{\text{WR}}$ (RWP) signals, shown in Table 3.

Table 3

Shared A0P	6800 Series WRP	8080 Series		Function
		$\overline{\text{RD}}$	$\overline{\text{WR}}$	
1	1	0	1	Read the display data
1	0	1	0	Write the display data
0	1	0	1	Read Status
0	0	1	0	Write control data (command)

6.1.3. The serial interface

When the serial interface is selected (PS = 'L') and when the chip is in active state ($\overline{\text{CS1}}$ = 'L' and CS2 = 'H'), the serial data input (SI) and the serial clock input (SCL) can be received. The serial data is read from the serial data input pin at the rising edge of the serial clocks DB7, DB6 through DB0 in order. The data is converted to 8-bit parallel data at the rising edge of the eighth serial clock.

The A0P input determines whether the serial data input is display data or command data; when A0P = 'H', the data is display data, and when A0P = 'L', the data is command data. The A0P input is read and used for detecting every 8th rising edge of the serial clock after the chip is active.

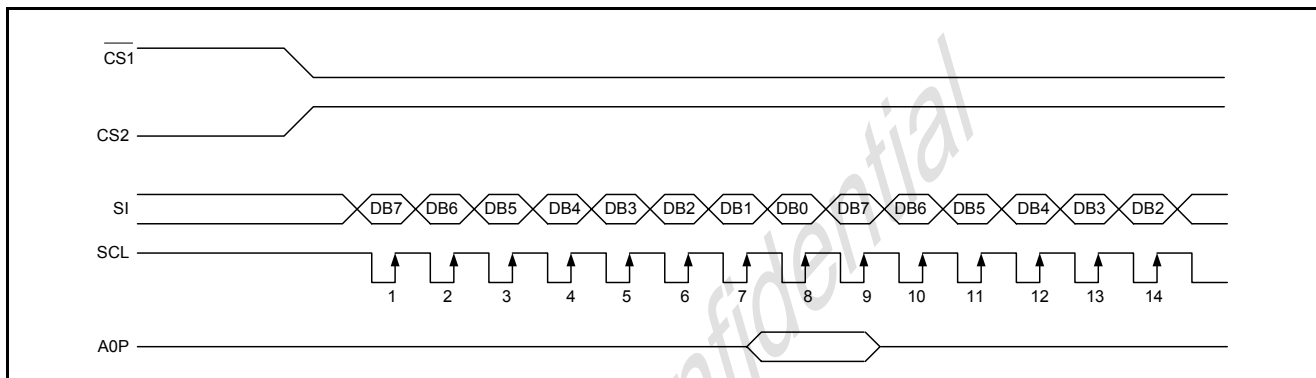

Figure 1: serial interface signal chart.

Note1: When the chip is not active, the shift registers and counter are reset to their initial states.

Note2: Reading is not acceptable in serial interface mode.

Note3: Caution is required on the SCL signal when it comes to line-end reflections and external noise. ORISE recommends that operation should be rechecked on the actual equipment.

6.2. The Chip Select

The SPLC502B have two chip-select-terminals: CS1 and CS2.

The MPU interface or the serial interface is enabled only when CS1 = 'L' and CS2 = 'H'.

When the chip select is inactive, DB7 - 0 enter into a high impedance state, and the A0P, RD, and WR inputs are inactive. When the serial interface is selected, the shift register and the counter are reset.

6.3. Accessing the Display Data RAM and the Internal Registers

Data transferring at a high speed is ensured since the MPU is required to satisfy the cycle time (t_{CYC}) requirement alone in accessing the SPLC502B. Wait time may not be considered. Also, in SPLC502B chips, each time data is sent from MPU. A type of pipeline process between LSIs is performed through the bus holder attached to the internal data bus. For example, when the MPU writes data to the display data RAM, once the data is stored in the bus holder, it is written to the display data RAM before the next data write cycle. Moreover, when the MPU reads the display data RAM, the first data read cycle (dummy) stores the read data in the bus holder, and then the data is read from the bus holder to the system bus at the next data read cycle. There is a certain restriction in the read sequence of the display data RAM. Note that data of the specified address is not generated by the read instruction issued immediately after the address setup. This data is generated in data read of the second time. Thus, a dummy read is required whenever the addresses setup or write cycle operation is conducted. This relationship is shown in Figure 2.

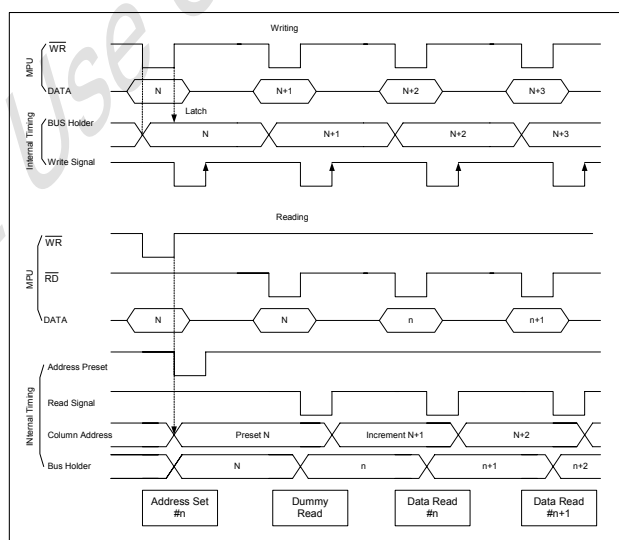

Figure2

6.4. The Busy Flag

When the busy flag is '1', it indicates that the SPLC502B is running internal processes. At this moment, no command aside from a status read will be received. The busy flag is outputted to DB7 pin with the read instruction. If the cycle time (t_{CYC}) is remained, it is not necessary to check for this flag before each command. This makes vast improvements in MPU processing capabilities possible.

6.5. Display Data RAM

6.5.1. Display data RAM

The display data RAM is a RAM that stores the dot data for the display. It has a 65 (8 page x 8 bit +1) x 132-bit structure. It is possible to access the desired bit by specifying the page address and the column address. Because, as is shown in Figure 3, the DB7 - 0 display data from the MPU corresponds to the liquid crystal display common direction, there are few constraints at the time of display data transfer when multiple SPLC502B chips are used. Therefore, display structures can be created easily and with a high degree of freedom.

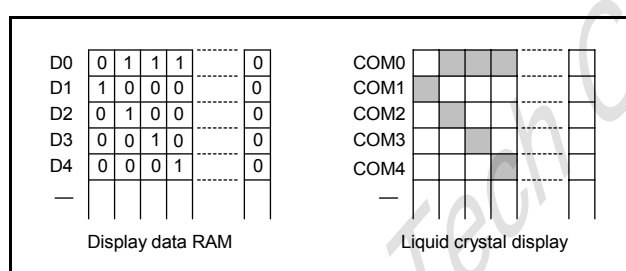

Figure 3

Moreover, reading from and writing to the display RAM in the MPU side is performed through the I/O buffer, which is an independent operation from signal reading for the liquid crystal driver. Consequently, even if the display data RAM is accessed asynchronously during liquid crystal display, it will not cause adverse effects on the display (such as flickering).

6.5.2. The page address circuit

As shown in Figure 4, page address of the display data RAM is specified through the Page Address Set Command. The page address must be specified again when changing pages to perform access. Page address 8 (DB3, DB2, DB1, DB0 = 1, 0, 0, 0) is the page for the RAM region used only by the indicators, and only display data DB0 is used.

6.5.3. The column addresses

As is shown in Figure 4, the display data RAM column address is specified by the Column Address Set command. The specified column address is incremented (+1) with each display data read/write command. This allows the MPU display data to be accessed continuously. Moreover, the increment of column addresses stops with 83H. Because the column address depends ON the page address, it is necessary to re-specify both the page address and the column address when moving, for example, from page 0 column 83H to page 1 column 00H. Furthermore, as is shown in Table 4, the ADC command (segment driver direction select command) can be used to reverse the relationship between the display data RAM column address and the segment output. Because of this, the constraints on the IC layout when the LCD module is assembled can be minimized.

Table 4

SEG Output	SEG0	SEG131
ADC '0'	0 (H) →	Column Address →83(H)
(DB0) '1'	83(H) ←	Column Address ← 0(H)

6.5.4. The line address circuit

The line address circuit, as shown in Figure 4, specifies the line address relating to the COM output when the contents of the display data RAM are displayed. Using the display start line address set command, which is normally the top line of the display can be specified. This is the COM0 output when the common output mode is normal and the COM63 output for SPLC502B when the common output mode is reversed. The display area is a 65-line area for the SPLC502B from the display start line address. If the line addresses are changed dynamically using the display start line address set command, screen scrolling, page swapping, ...etc. can be performed.

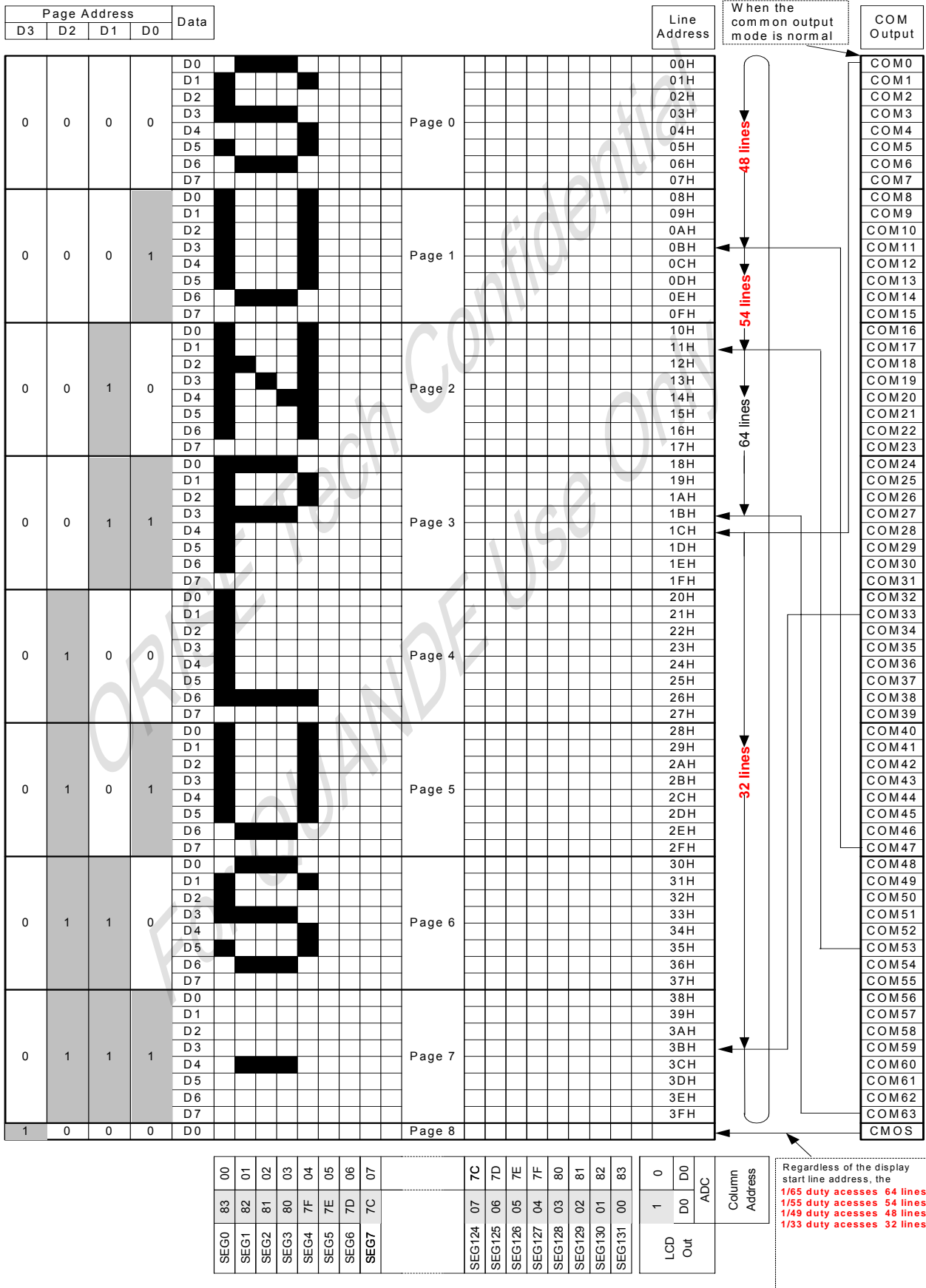

Figure 4

6.6. The Display Data Latch Circuit

The display data latch circuit temporarily stores the display data that is output to the liquid crystal driver circuit from the display data RAM. Because the display normal/reverse status, display ON/OFF status, and display all points ON/OFF commands control only the data within the latch, they do not change the data within the display data RAM itself.

6.7. The Oscillator Circuit

This is a CR-type oscillator that produces the display clock. The oscillator circuit is only enabled when MS = 'H' and CLS = 'H'. When CLS = 'L', the oscillation stops, and the display clock is input through the CL terminal.

6.8. The Common Output Status Select

In the SPLC502B chips, the COM output scan direction can be selected by the common output status select command (See Table 5.). Consequently, the constraints in IC layout at the time of LCD module assembly can be minimized.

Table 5

Status	COM Scan Direction			
	1/65 Duty	1/55 Duty	1/49 Duty	1/33 Duty
Normal	COM0 → COM63	COM0 → COM53	COM0 → COM47	COM0 → COM31
Reverse	COM63 → COM0	COM53 → COM0	COM47 → COM0	COM31 → COM0

Duty	Status	Common output pads							COMS
		COM [0:15]	COM [16:23]	COM [24:26]	COM [27:36]	COM [37:39]	COM [40:47]	COM [48:63]	
1/65	Normal	COM [0:63]							COMS
	Reverse	COM [63:0]							
1/55	Normal	COM [0:26]		NC	COM [27:53]				COMS
	Reverse	COM [53:27]		NC	COM [26:0]				
1/49	Normal	COM [0:23]		NC	COM [24:47]				COMS
	Reverse	COM [47:24]		NC	COM [23:0]				
1/33	Normal	COM [0:15]	NC				COM [16:31]		COMS
	Reverse	COM [31:16]	NC				COM [15:0]		

6.9. Display Timing Generator Circuit

The display timing generator circuit generates the timing signal to the line address circuit and the display data latch circuit using the display clock. The display data is latched into the display data latch circuit synchronized with the display clock, and is output to the data driver output terminal. Reading to the display data liquid crystal driver circuits is completely independent of accesses to the display data RAM by the MPU. Consequently, even if the display

data RAM is accessed asynchronously during liquid crystal display, there is absolutely no adverse effect (such as flickering) on the display. Moreover, the display timing generator circuit generates the common timing and the liquid crystal alternating current signal (FR) from the display clock. It generates a drive-wave form using a 2-frame alternating current drive method, as is shown in Figure 5, for the liquid crystal drive circuit.

Two-frame alternating current drive-wave form (SPLC502B)

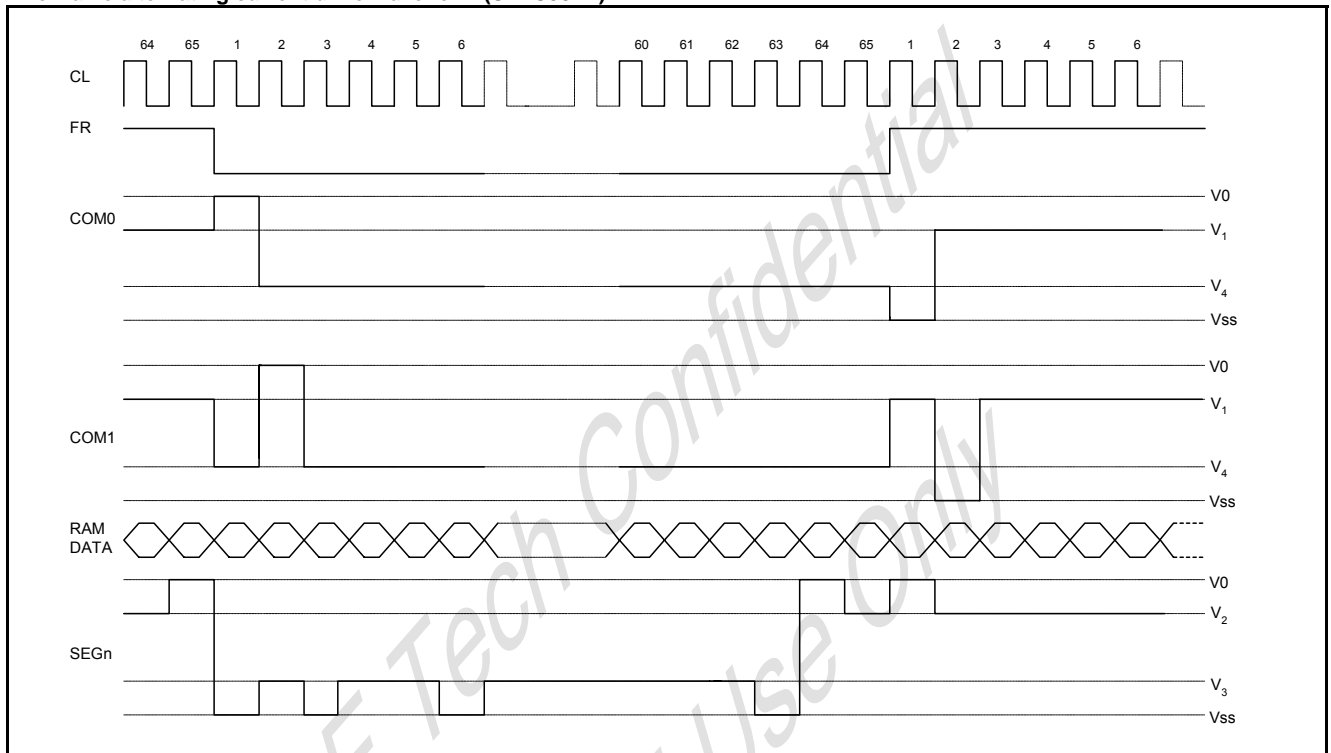

Figure 5

When multiple SPLC502B chips are used, the slave chips must be supplied the display timing signals (FR, CL, $\overline{\text{DOF}}$) from the master chip(s). Table 6 shows the status of the FR, CL, and $\overline{\text{DOF}}$ signals.

Table 6

Operating Mode	FR	CL	$\overline{\text{DOF}}$
Master (MS = 'H'): The internal oscillator circuit is enabled (CLS = 'H')	Output	Output	Output
The internal oscillator circuit is disabled (CLS = 'L')	Output	Input	Output

Operating Mode	FR	CL	$\overline{\text{DOF}}$
Slave (MS = 'L'): The internal oscillator circuit is enabled (CLS = 'H')	Input	Input	Input
The internal oscillator circuit is disabled (CLS = 'L')	Input	Input	Input

6.10. The Liquid Crystal Driver Circuits

These are a 197-channel (SPLC502B) that generates four voltage levels for driving the liquid crystal. The combination of the display data, the COM scan signals, and the FR signal produces the liquid

crystal drive voltage output. Figure 6 shows examples of the SEG and COM output waveform.

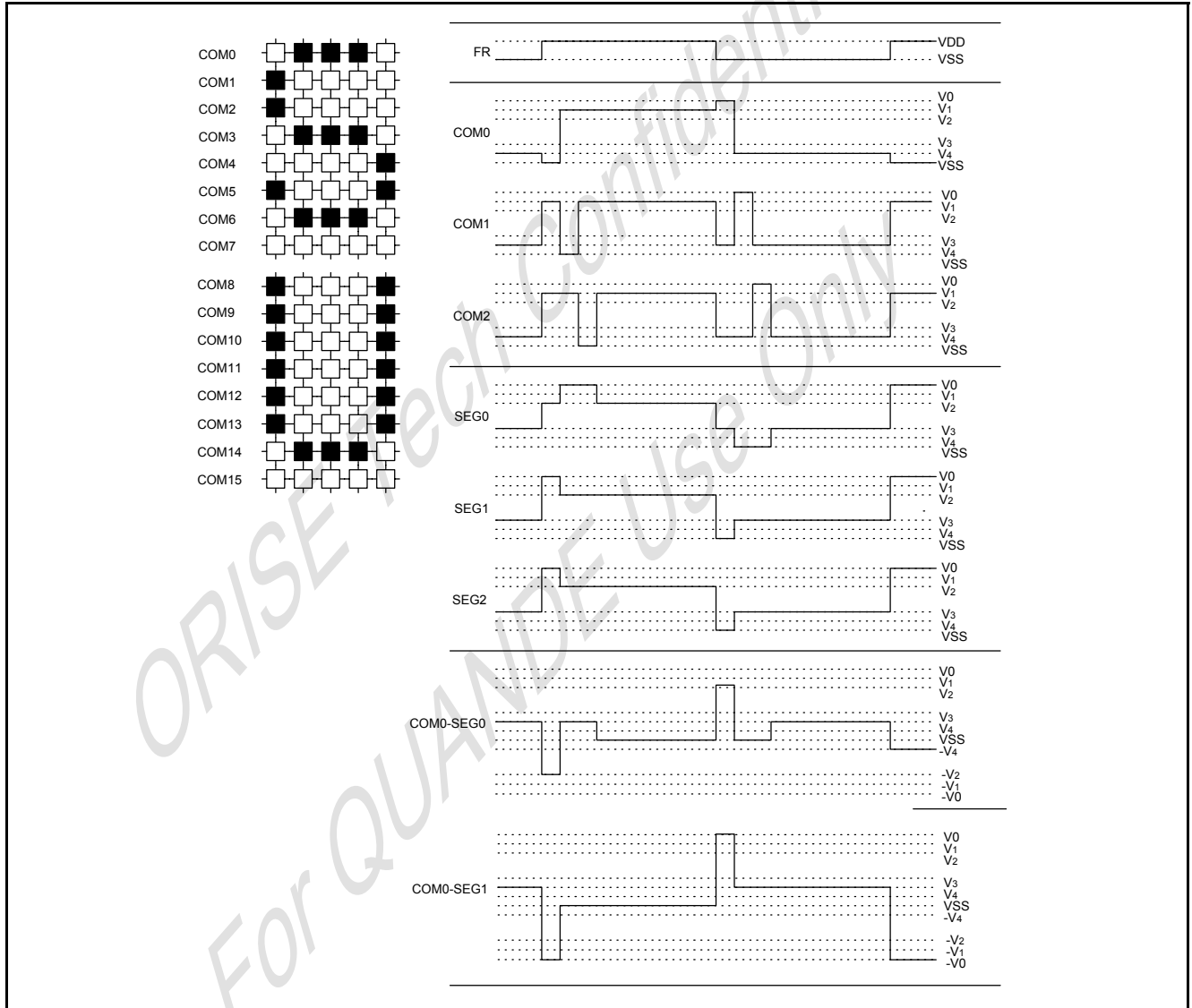

Figure 6

6.11. The Power Supply Circuits

The power supply circuits are low-power consumption power supply circuits that generate the voltage levels for the liquid crystal drivers. They comprise Booster circuits, voltage regulator circuits, and voltage follower circuits. They are only enabled in master operation. The power supply circuits can turn the Booster circuits, the voltage regulator circuits, and the voltage follower circuits ON or OFF independently through the use of the Power Control Set command. Consequently, it is possible to make an external power supply and the internal power supply function in parallel. Table 7 shows the Power Control Set Command 3-bit data control functions, and Table 8 shows reference combinations.

Table 7 The Control Details of Each Bit of the Power Control Set Command

Item	Status	
	'1'	'0'
DB2 Booster circuit control bit	ON	OFF
DB1 Voltage regulator circuit (V regulator circuit) control bit	ON	OFF
DB0 Voltage follower circuit (V/F circuit) control bit	ON	OFF

Table 8 Reference Combinations

Use Settings	DB0	DB1	DB0	Step-up circuit	V regulator circuit	V/F circuit	External voltage input	Step-up Voltage System Terminal
Only the internal power supply is used	1	1	1	O	O	O	VDD2	Used
Only the V regulator circuit and the V/F circuit are used	0	1	1	X	O	O	V _{OUT} , VDD2	Open
Only the V/F circuit is used	0	0	1	X	X	O	V ₀ , VDD2	Open
Only the external power supply is used	0	0	0	X	X	X	V ₀ to V ₄	Open

Note1: The 'step-up system terminals' refer CAP1P, CAP1N, CAP2P, CAP2N, and CAP3N.

Note2: While other combinations, not shown above, are also possible, these combinations are not recommended because they have no practical use.

6.11.1. The step-up voltage circuits

Using the step-up voltage circuits equipped within the SPLC502B chips, it is possible to product a 6 Times, 5 Times, Quad step-up, a Triple step-up, and a Double step-up of the VDD2 - VSS voltage levels.

6 Times step-up: Connect capacitor C1 between CAP1P and CAP1N, between CAP2P and CAP2N, between CAP1N and CAP3N, between CAP2N and CAP4P, between CAP1N and CAP5P, and between VOUT and VSS, to produce a voltage level in the positive direction at the VOUT terminal that is 6 times the voltage level between VDD2 and VSS.

5 Times step-up: Connect capacitor C1 between CAP1P and CAP1N, between CAP2P and CAP2N, between CAP1N and CAP3N, between CAP2N and CAP4P, between VOUT and VSS, short between CAP5P and VOUT, to produce a voltage level in the positive direction at the VOUT terminal that is 4 times the voltage level between VDD2 and VSS.

Quad step-up: Connect capacitor C1 between CAP1P and CAP1N, between CAP2P and CAP2N, between CAP1N and CAP3N, and between VOUT and VSS, to produce a voltage level in the positive direction at the VOUT terminal that is 4 times the voltage level between VDD2 and VSS.

Triple step-up: Connect capacitor C1 between CAP1P and CAP1N, between CAP2P and CAP2N and between VOUT and VSS, and short between CAP3P and VOUT, to produce a voltage level in the positive direction at the VOUT terminal that is 3 times the voltage difference between VDD2 and VSS.

Double step-up: Connect capacitor C1 between CAP1P and CAP1N, and between VOUT and VSS, leave CAP2N open, and short between CAP2P and VOUT, to produce a voltage in the positive direction at the VOUT terminal that is twice the voltage between VDD2 and VSS.

The step-up voltage relationships are shown in Figure 7.

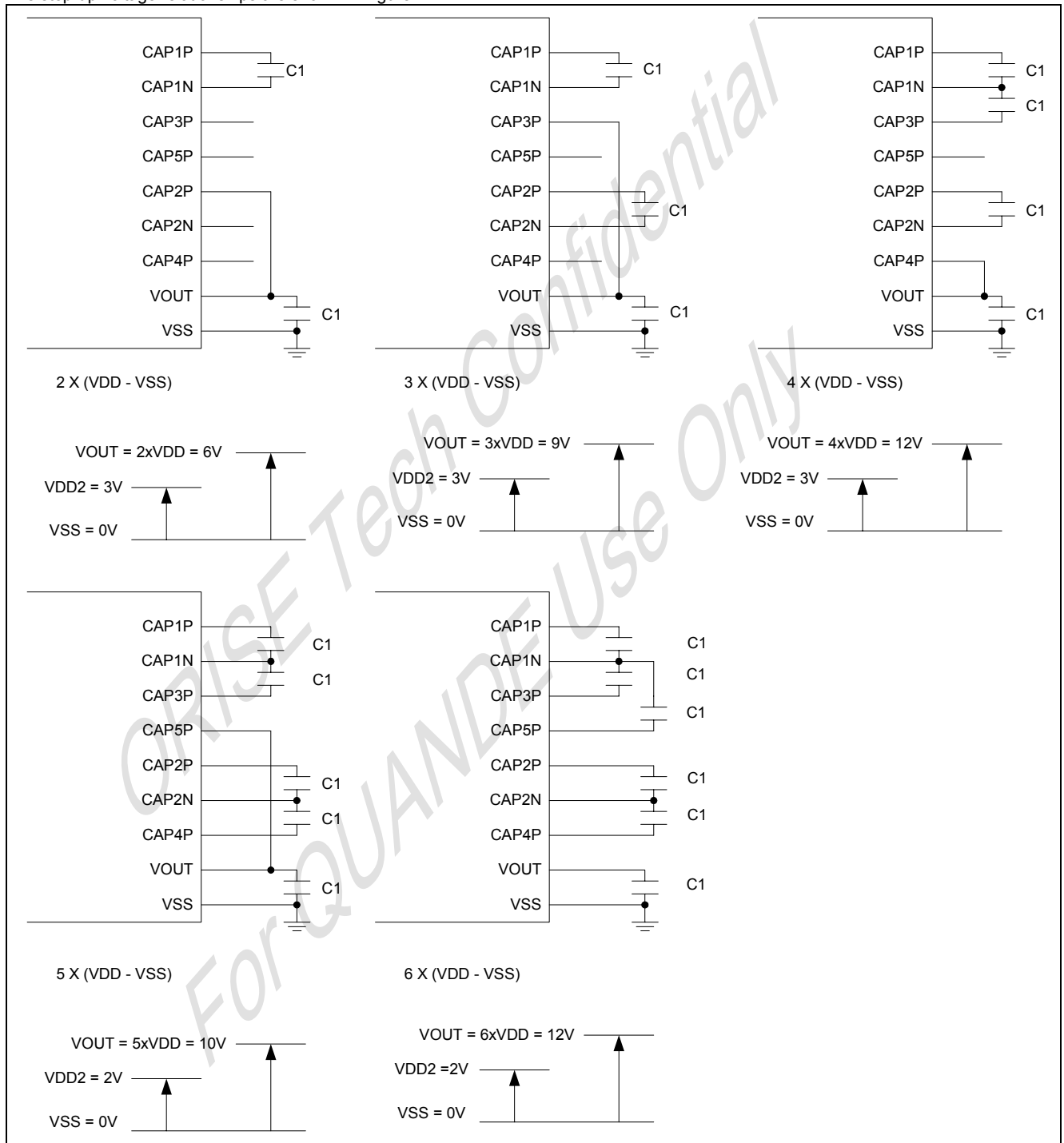

Figure 7

Note: The VDD2 voltage range must be set so that the VOUT terminal voltage does not exceed the absolute maximum rate.

The Recommended C1 capacitor is 1.0u~2.2u.

6.11.2. The voltage regulator circuit

The step-up voltage generated at V_{OUT} outputs the liquid crystal driver voltage V_0 through the voltage regulator circuit. For display quality issue, the condition $V_{OUT} \geq V_0 + 1.0V$ must be satisfied for all application condition. Because the SPLC502B chips have an internal high-accuracy fixed voltage power supply with a 64-level electronic volume function and internal resistors for the V_0 voltage regulator, systems can be constructed without having to include high-accuracy voltage regulator circuit components. Moreover, in the SPLC502B, thermal gradients have been prepared as V_{REG} approximately $-0.05\%/^{\circ}C$

6.11.2.1. When the V_0 voltage regulator internal resistors are used

Through the use of the V_0 voltage regulator internal resistors and the electronic volume function, the liquid crystal power supply voltage, V_0 , can be controlled by commands alone (without adding any external resistors), making it possible to adjust the liquid crystal display brightness. The V_0 voltage can be calculated using equation A-1 over the range where $|V_0| < |V_{OUT}|$.

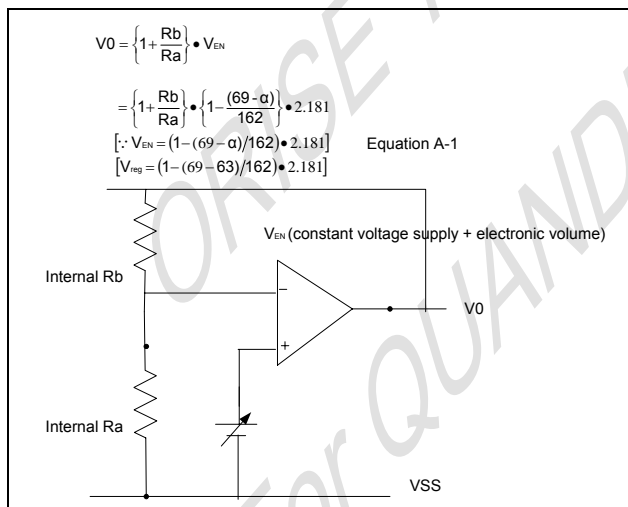

Figure 8

V_{REG} is the IC-internal fixed voltage supply, and its voltage at $T_A = 25^{\circ}C$ is as shown in Table 9.

Table 9

Equipment Type	Thermal Gradient	Units	VREG	Units
Internal Power Supply	-0.05	[%/ $^{\circ}C$]	2.1	[V]

α is set to 1 level of 64 possible levels by the electronic volume function depending on the data set in the 6-bit electronic volume register. Table 10 shows the value for depending on the electronic volume register settings.

Table 10

DB5	DB4	DB3	DB2	DB1	DB0	α
0	0	0	0	0	0	0
0	0	0	0	0	1	1
0	0	0	0	1	0	2
:	:	:	:	:	:	:
1	1	1	1	0	1	61
1	1	1	1	1	0	62
1	1	1	1	1	1	63

R_b/R_a is the V_0 voltage regulator internal resistor ratio, and can be set to 8 different levels through the V_0 voltage regulator internal resistor ratio set command. The $(1 + R_b/R_a)$ ratio assumes the values shown in Table 11 depending on the 3-bit data settings in the V_0 voltage regulator internal resistor ratio register.

V_0 voltage regulator internal resistance ratio register value and $(1 + R_b/R_a)$ ratio (Reference value)

Table 11

Register	SPLC502B		
	Equipment Type by Thermal Gradient [Units: %/ $^{\circ}C$]		
DB2 DB1 DB0	(1) -0.05		
0 0 0	3.0		
0 0 1	3.5		
0 1 0	4.0		
0 1 1	4.5		
1 0 0	5.0		
1 0 1	5.5		
1 1 0	6.0		
1 1 1	6.5		

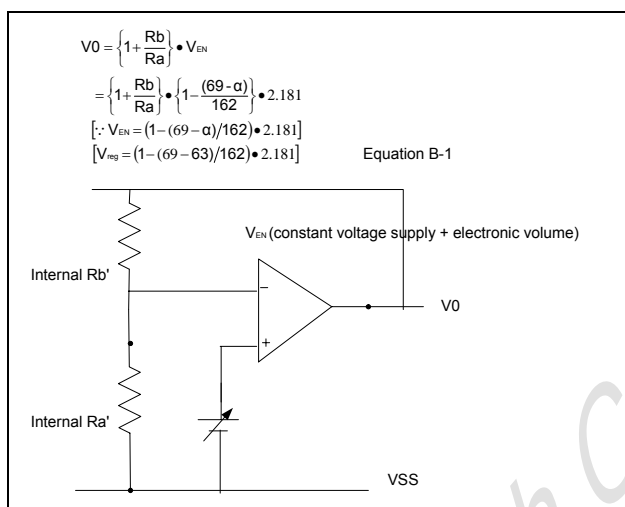
Figure 9

Note1: When the V0 voltage regulator internal resistors or the electronic volume function is used, it is necessary to at least set the voltage regulator circuit and the voltage follower circuit to an operating mode

The V0 voltage is produced by a resistive voltage divider within the IC, and can be produced at the V₁, V₂, V₃, and V₄ voltage levels required for liquid crystal driving. Moreover, when the voltage follower changes the impedance, it provides V₁, V₂, V₃ and V₄ to the liquid crystal drive circuit. 1/9 bias or 1/7 bias for SPLC502B can be selected.

6.12. High Power Mode

The power supply circuit equipped in the SPLC502B chips has very low power consumption (normal mode: HPM = 'H'). However, for LCDs or panels with large loads, this low-power power supply may cause display quality to degrade. When this occurs, setting the HPM terminal to 'L' (high power mode) can improve the quality of the display. We recommend that the display be checked on actual equipment to determine whether or not to use this mode. Moreover, if the improvement to the display is inadequate even

using the power control set commands. Moreover, it is necessary to provide a voltage from VOUT when the Booster circuit is OFF.

after high power mode has been set, it is necessary to add a liquid crystal drive power supply externally.

6.13. The Internal Power Supply Shutdown Command Sequence

The sequence shown in Figure 11 is recommended for shutting down the internal power supply. First place the power supply in power saver mode and then turn the power supply OFF.

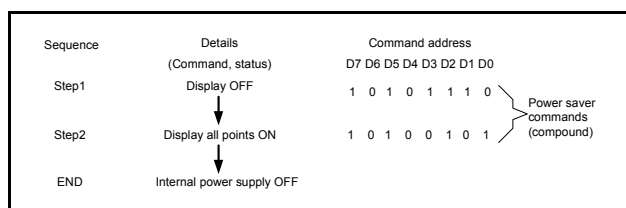
Figure 11

6.14. Reference Circuit Examples

Figure 12 shows reference circuit examples.

Note: The C3 capacitor of V1, V2, V3 and V4 may be used or not, depending on panel loading. If the panel loading is large, the C3 capacitor and High Power mode (HPM = 'L') are suggested. The Recommended C2 and C3 capacitor is 0.1u~4.7u.

6.14.1.1. When using all of the step-up circuit, voltage regulating circuit and V/F circuit

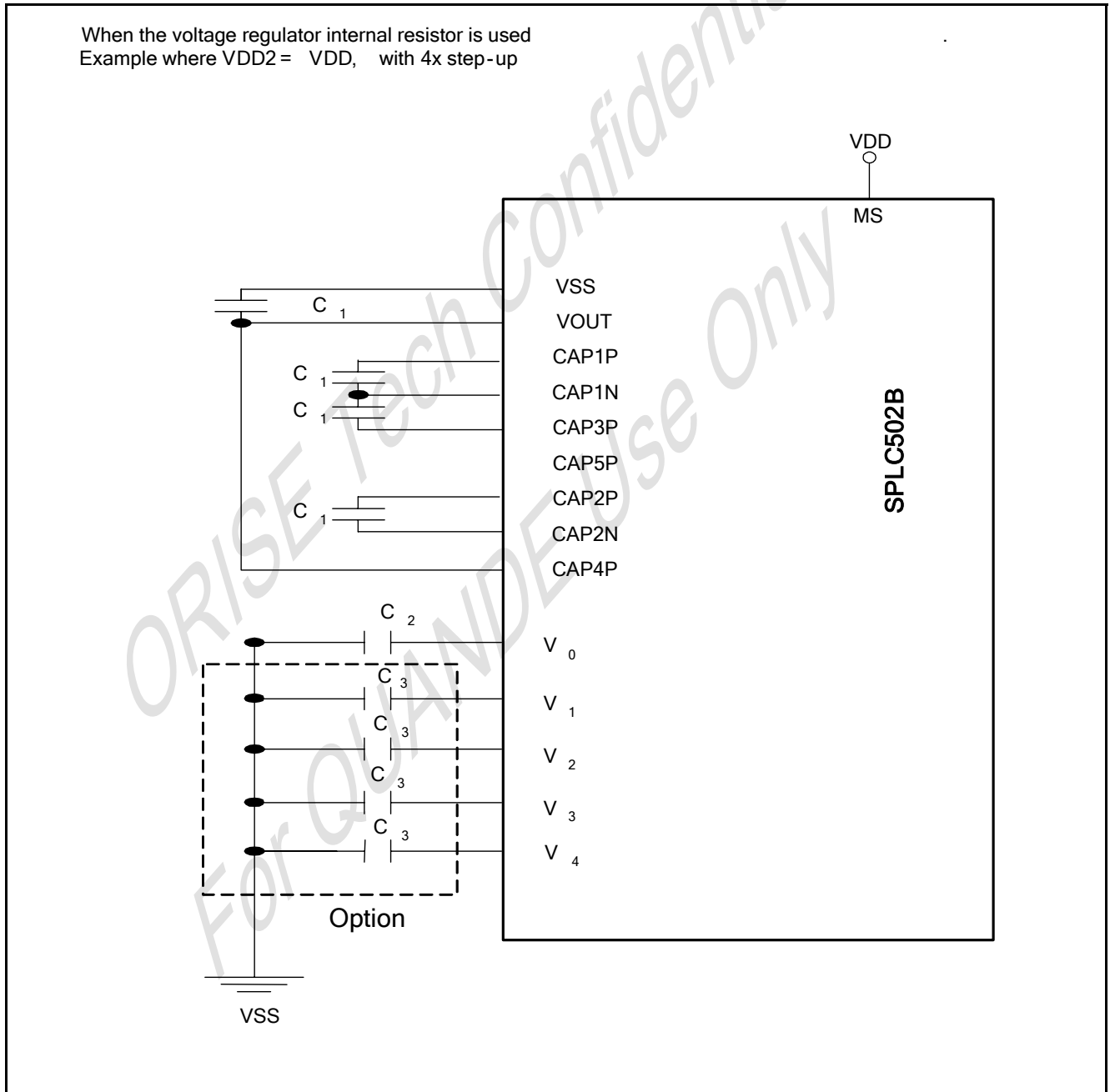

Figure 12

6.14.1.2. When the voltage regulator circuit and V/F circuit alone are used

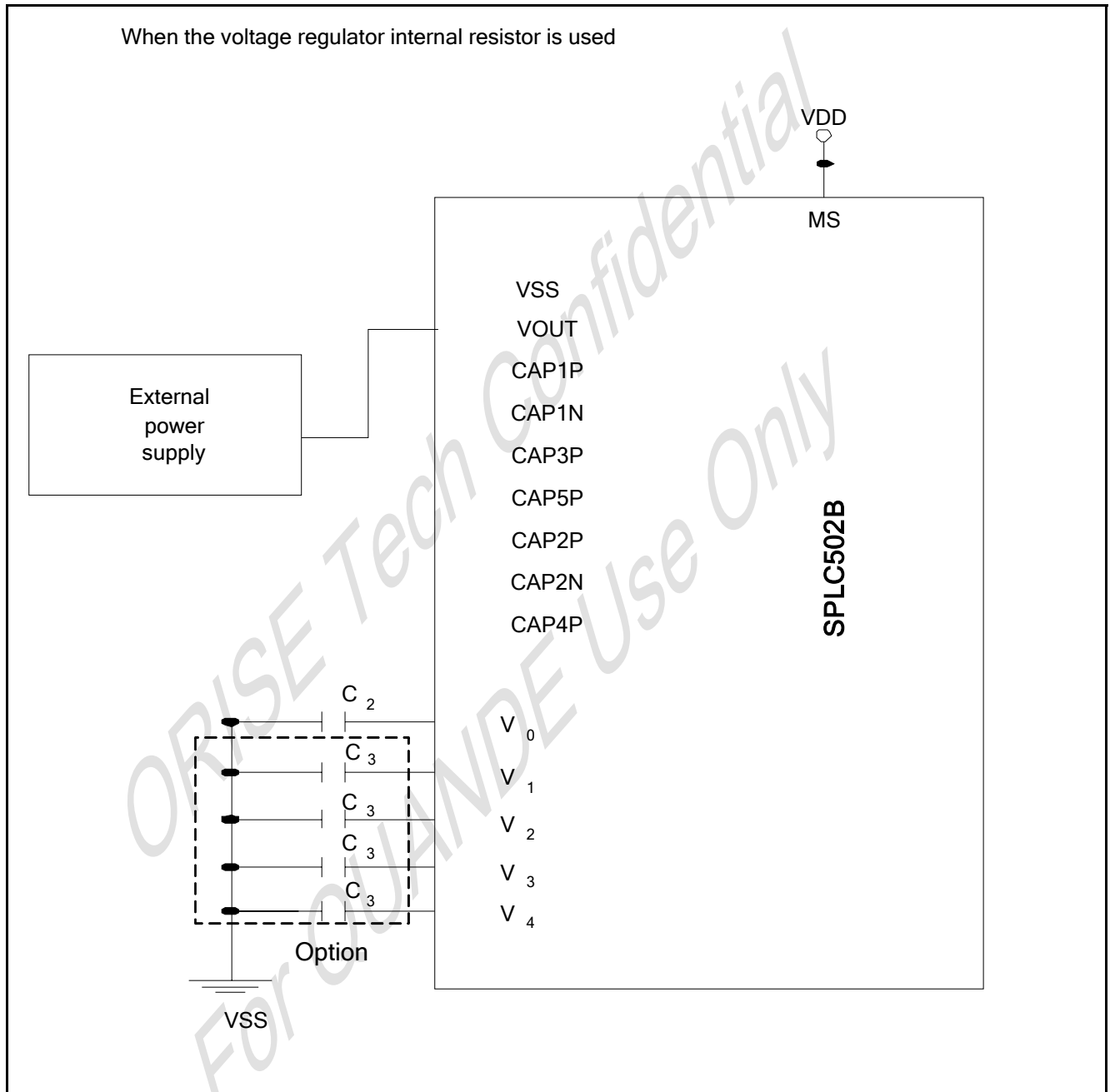

Figure 13

Item	Set Value	Units
C1	1.0 to 2.2	uF
C2	0.1 to 4.7	uF
C3	0.1 to 4.7	uF

6.15. The Reset Circuit

When the RESET input comes to the 'L' level, these LSIs return to the default state. Their default states are as follows:

- 1). Display OFF
- 2). Normal display
- 3). ADC select: Normal (ADC command DB0 = 'L')
- 4). Power control register: (DB2, DB1, DB0) = (0, 0, 0)
- 5). Serial interface internal register data clear
- 6). LCD power supply bias rate:
SPLC502B.....1/9 bias
- 7). All-indicator lamps-on OFF (All-indicator lamps ON/OFF command DB0 = 'L')
- 8). Power saving clear
- 9). V0 voltage regulator internal resistors, Ra and Rb, are connected.
- 10). Output conditions of SEG and COM terminals
SEG: VSS, COM: VSS
- 11). Read modify write OFF
- 12). Static indicator OFF
Static indicator register: (DB1, DB2) = (0, 0)
- 13). Display start line set to first line
- 14). Column address set to Address 0
- 15). Page address set to Page 0
- 16). Common output status normal
- 17). V0 voltage regulator internal resistor ratio set mode clear
- 18). Electronic volume register set mode clear
Electronic volume register: (DB5, DB4, DB3, DB2, DB1, DB0) = (1, 0, 0, 0, 0, 0)
- 19). Test mode clear
- 20). Driving mode register(DB0)=(0)

On the other hand, when the reset command is used, only above default settings from 11 to 19 are executed. When the power is turned on, the IC internal state becomes unstable, and it is necessary to initialize it using the RESET terminal. After the initialization, each input terminal should be controlled normally. Moreover, when the control signal from the MPU is in the high impedance, an over-current may flow to the IC. After applying a current, it is necessary to take proper measures to prevent the input terminal from getting into the high impedance state. If the internal liquid crystal power supply circuit is not used on SPLC502B, it is necessary that RESET is 'H' when the external liquid crystal power supply is turned on. This IC has the function to discharge V0 when RESET is 'L,' and the external power

supply short-circuits to VDD when RESET is 'L.'. While RESET is 'L,' the oscillator and the display timing generator stop, and the CL, FR, FRS and DOF terminals are fixed to 'H'. The terminals DB7 - 0 are not affected. The VDD level is output from the SEG and COM output terminals. It means that an internal resistor is connected between VDD and V0. When the internal liquid crystal power supply circuit is not used on other models of SPLC502B, it is necessary that RESET is 'L' when the external liquid crystal power supply is turned on. While RESET is 'L,' the oscillator works, but the display timing generator stops, and the CL, FR, FRS and DOF terminals are fixed to 'H'. The terminals DB7 - 0 are not affected.

7. COMMANDS

The SPLC502B chips identify the data bus signals by a combination of A0P, RD (EP), WR (RWP) signals. Command interpretation and execution do not depend on the external clock, but rather is performed through internal timing only, and thus the processing is fast enough that normally a busy check is not required.

In the 8080 MPU interface, commands are launched by inputting a low pulse to the RD terminal for reading, and inputting a low pulse to the WR terminal for writing. In the 6800 Series MPU interface, the interface is placed in a read mode when a 'H' signal is input to the RWP terminal. It is placed in a write mode when a 'L' signal is input to the RWP terminal. Then, the command is launched by inputting a high pulse to the EP terminal (See '10. Timing Characteristics' regarding the timing). Consequently, the 6800 Series MPU interface is different from the 80x86 Series MPU interface in that in the explanation of commands and the display commands the status read and display data read RD (EP) becomes '1(H)'. In the explanations below, the commands are explained using the 8080 Series MPU interface as the example. When the serial interface is selected, the data is inputted in the sequence starting from DB7.

<Explanation of Commands>

7.1. Display ON/OFF

This command turns the display ON and OFF.

A0P	EP	RWP	DB7	DB6	DB5	DB4	DB3	DB2	DB1	DB0	Setting
	RD	WR									
0	1	0	1	0	1	0	1	1	1	1	Display ON
										0	Display OFF

When the display OFF command is executed and when in the display all points ON mode, power saver mode is entered. See the section on the power saver for details.

7.2. Display Start Line Set

This command is used to specify the display start line address of the display data RAM shown in Figure 4. For further details, see the explanation of this function in 'The Line Address Circuit'.

A0P	EP	RWP	DB7	DB6	DB5	DB4	DB3	DB2	DB1	DB0	Line Address
	RD	WR									
0	1	0	0	1	0	0	0	0	0	0	0
					0	0	0	0	0	1	1
					0	0	0	0	1	0	2
								↓			↓
					1	1	1	1	1	0	62
					1	1	1	1	1	1	63

7.3. Page Address Set

This command specifies the page address corresponding to the low address when the MPU accesses the display data RAM (see Figure 4). Specifying the page address and column address enables to access a desired bit of the display data RAM.

Changing the page address does not accompany a change in the status display. See the page address circuit in the Function Description (page 12) for the detail.

A0P	EP	RWP	DB7	DB6	DB5	DB4	DB3	DB2	DB1	DB0	Page Address
	RD	WR									
0	1	0	1	0	1	1	0	0	0	0	0
							0	0	0	1	1
							0	0	1	0	2
									↓		↓
							0	1	1	1	7
							1	0	0	0	8

7.4. Column Address Set

This command specifies the column address of the display data RAM shown in Figure 4. The column address is split into two sections (the higher 4 bits and the lower 4 bits) when it is set (fundamentally, set continuously). Each time the display data RAM is accessed, the column address automatically incremented (+1),

making it possible for the MPU to continuously read from/write to the display data. The column address increment is topped at 83H. This does not change the page address continuously. See the function explanation in 'The Column Address Circuit' for details.

	EP		RWP		DB7	DB6	DB5	DB4	DB3	DB2	DB1	DB0	A7	A6	A5	A4	A3	A2	A1	A0	Column Address	
	A0P	RD	WR	WR																		
High bits →	0	1	0		0	0	0	1	A7	A6	A5	A4	0	0	0	0	0	0	0	0	0	0
Low bits →								0	A3	A2	A1	A0	0	0	0	0	0	0	0	1	1	1
													0	0	0	0	0	0	1	0		↓
													1	0	0	0	0	0	0	0		130
													1	0	0	0	0	0	1	1		131

7.5. Status Read

A0P	EP		RWP		DB7	DB6	DB5	DB4	DB3	DB2	DB1	DB0
	RD	WR	WR	WR								
0	0			1	BUSY	ADC	ON/OFF	RESET	0	0	0	0

BUSY	When BUSY = '1', it indicates that either processing is occurring internally or a reset condition is in process. While the chip does not accept commands until BUSY = '0', if the cycle time can be satisfied, there is no need to check for BUSY condition.
ADC	This shows the relationship between the column address and the segment driver. 0: Reverse (column address 131-n ↔ SEG n) 1: Normal (column address n ↔ SEG n) (The ADC command switches the polarity.)
ON/OFF	ON/OFF: indicates the display ON/OFF state. 0: Display ON 1: Display OFF (This display ON/OFF command switches the polarity.)
RESET	This indicates that the chip is in the process of initialization either because of a RESET signal or because of a reset command. 0: Operating state 1: Reset in progress

7.6. Display Data Write

This command writes 8-bit data to the specified display data RAM address. Since the column address is automatically incremented

by one after the write, the MPU can write the display data.

A0P	$\overline{\text{EP}}$ RD	$\overline{\text{RWP}}$ WR	DB7	DB6	DB5	DB4	DB3	DB2	DB1	DB0
1	1	0	Write data							

7.7. Display Data Read

This command reads 8-bit data from the specified display data RAM address. Since the column address is automatically incremented by one after the read, the CPU can continuously read multiple-word data. One dummy read is required immediately

after the column address being set. See the function explanation in "Display Data RAM" for the explanation of accessing the internal registers. When the serial interface is used, reading the display data becomes unavailable.

A0P	$\overline{\text{EP}}$ RD	$\overline{\text{RWP}}$ WR	DB7	DB6	DB5	DB4	DB3	DB2	DB1	DB0
1	0	1	Read Data							

7.8. ADC Select (Segment Driver Direction Select)

This command can reverse the correspondence between the display RAM data column address and the segment driver output. Thus, sequence of the segment driver output pins may be reversed by the command. See the column address circuit (page

12) for the detail. Increment of the column address (by '1') accompanying the reading or writing the display data is done according to the column address indicated in Figure 4.

A0P	$\overline{\text{EP}}$ RD	$\overline{\text{RWP}}$ WR	DB7	DB6	DB5	DB4	DB3	DB2	DB1	DB0	Setting
0	1	0	1	0	1	0	0	0	0	0	Normal
										1	Reverse

7.9. Display Normal/Reverse

This command can reverse the lit and unlit display without overwriting the contents of the display data RAM. When this is

done, the display data RAM contents are maintained.

A0P	$\overline{\text{EP}}$ RD	$\overline{\text{RWP}}$ WR	DB7	DB6	DB5	DB4	DB3	DB2	DB1	DB0	Setting
0	1	0	1	0	1	0	0	1	1	0	RAM Data 'H' LCD ON voltage (normal)
										1	RAM Data 'L' LCD ON voltage (reverse)

7.10. Display All Points ON/OFF

This command makes it possible to force all display points ON regardless of the content of the display data RAM. The contents of the display data RAM are maintained when this is done. This

command takes priority over the display normal/reverse command.

A0P	$\overline{\text{EP}}$ RD	$\overline{\text{RWP}}$ WR	DB7	DB6	DB5	DB4	DB3	DB2	DB1	DB0	Setting
0	1	0	1	0	1	0	0	1	0	0	Normal display mode
										1	Display all points ON

When the display is in an OFF mode, executing the display all points ON command will place the display in power save mode.

For more details, see the Power Save Section.

7.11. LCD Bias Set

This command selects the voltage bias ratio for the liquid crystal display.

A0P	$\overline{\text{EP}}$ RD	$\overline{\text{RWP}}$ WR	DB7	DB6	DB5	DB4	DB3	DB2	DB1	DB0	Select Status (Duty)			
											1/65	1/55	1/49	1/33
0	1	0	1	0	1	0	0	0	1	0	1/9 bias	1/8 bias	1/8 bias	1/6 bias
										1	1/7 bias	1/6 bias	1/6 bias	1/5 bias

7.12. Read/Modify/Write

This command is used paired with the 'END' command. Once this command has been inputted, the display data read command does not change the column address, but only the display data write command increment (+1) the column address. This mode remains until the END command is inputted. When the END

command is inputted, the column address returns to the address at when the read/modify/write command was entered. This function makes it possible to reduce the load on the MPU when there is repeating data changes in a specified display region, such as when there is a blanking cursor.

A0P	$\overline{\text{EP}}$ RD	$\overline{\text{RWP}}$ WR	DB7	DB6	DB5	DB4	DB3	DB2	DB1	DB0
0	1	0	1	1	1	0	0	0	0	0

Note: Even in read/modify/write mode, other commands aside from display data read/write commands can also be used. However, the column address set command cannot be used.

7.12.1. The sequence for cursor display

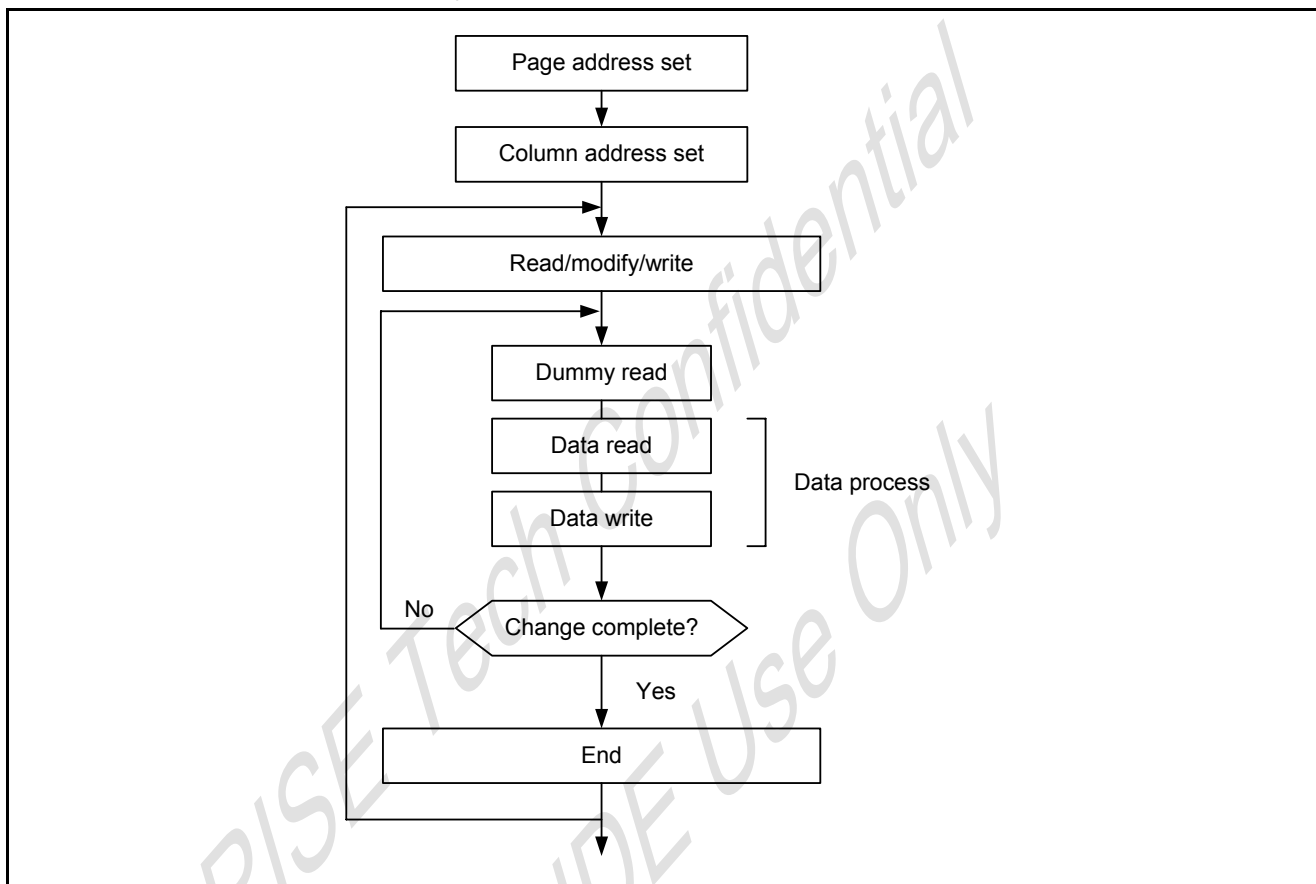

Figure 15

7.13. END

This command releases the read / modify / write mode, and returns the column address to the address at when the mode was entered.

A0P	EP RD	RWP WR	DB7	DB6	DB5	DB4	DB3	DB2	DB1	DB0
0	1	0	1	1	1	0	1	1	1	0

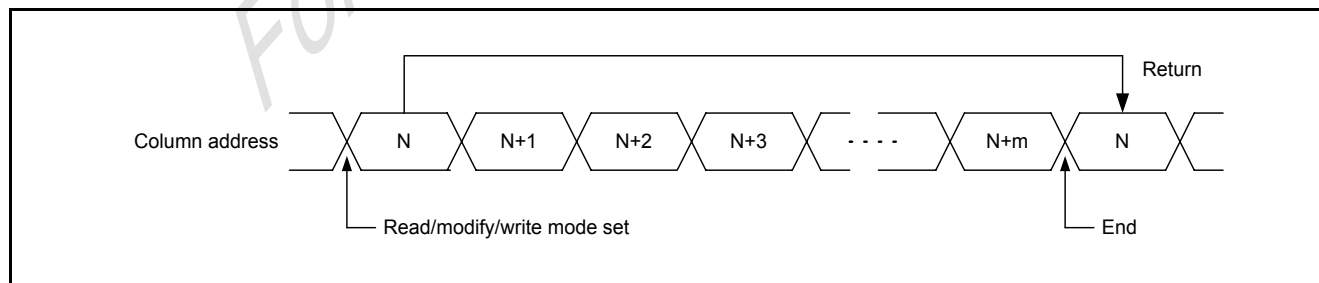

Figure 16

7.14. RESET

This command initializes the display start line, the column address, the page address, the common output mode, the V0 voltage regulator internal resistor ratio, the electronic volume, and the static indicator are reset, and the read/modify/write mode and test

mode are released. There is no impact on the display data RAM. See the function explanation in "Reset" for details. The reset operation is performed after the reset command is entered.

A0P	$\overline{\text{EP}}$ RD	$\overline{\text{RWP}}$ WR	DB7	DB6	DB5	DB4	DB3	DB2	DB1	DB0
0	1	0	1	1	1	0	0	0	1	0

The initialization must be done through applying a reset signal to the RESET terminal when the power supply is applied.

7.15. Common Output Mode Select

This command can select the scan direction of the COM output terminal. For details, see the function explanation in "Common

Output Mode Select Circuit".

A0P	$\overline{\text{EP}}$ RD	$\overline{\text{RWP}}$ WR	DB7	DB6	DB5	DB4	DB3	DB2	DB1	DB0	Select Status SPLC502B
0	1	0	1	1	0	0	0	*	*	*	Normal
							1				Reverse

Note: *Disabled bit

7.16. Power Controller Set

This command sets the power supply circuit functions. See the function explanation in "The Power Supply Circuit" for more details.

A0P	$\overline{\text{EP}}$ RD	$\overline{\text{RWP}}$ WR	DB7	DB6	DB5	DB4	DB3	DB2	DB1	DB0	Selected Mode
0	1	0	0	0	1	0	1	0			Booster circuit: OFF
								1			Booster circuit: ON
									0		Voltage regulator circuit :OFF
									1		Voltage regulator circuit: ON
										0	Voltage follower circuit: OFF
										1	Voltage follower circuit: ON

Note: Display off command masks the power control circuits

7.17. V0 Voltage Regulator Internal Resistor Ratio Set

This command sets the V0 voltage regulator internal resistor ratio. For details, see the function explanation in “The Power Supply Circuits”.

A0P	EP RD	RWP WR	DB7	DB6	DB5	DB4	DB3	DB2	DB1	DB0	Setting
0	1	0	0	0	1	0	0	0	0	0	Small
								0	0	1	
								0	1	0	
									↓		↓
								1	1	0	
								1	1	1	Large

7.18. The Electronic Volume (Double Byte Command)

This command makes it possible to adjust the brightness of the liquid crystal display by controlling the liquid crystal drive voltage V0 through the output from the voltage regulator circuits of the internal liquid crystal power supply. This command is a two bytes command used as a pair with the electronic volume mode set command and the electronic volume register set command, and both commands must be issued one after the other.

7.18.1. The electronic volume mode set

When this command is input, the electronic volume register set command becomes enabled. Once the electronic volume mode has been set, no other command except for the electronic volume register set command can be used. Once the electronic volume register set command has been used to set data into the register, the electronic volume mode is released.

A0P	EP RD	RWP WR	DB7	DB6	DB5	DB4	DB3	DB2	DB1	DB0
0	1	0	1	0	0	0	0	0	0	1

7.18.2. Electronic volume register set

By using this command to set six bits of data to the electronic volume register, the liquid crystal driving voltage, V0, assumes one of the 64 voltage levels. When this command is input, the

electronic volume mode is released after the electronic volume register has been set.

A0P	EP RD	RWP WR	DB7	DB6	DB5	DB4	DB3	DB2	DB1	DB0	V0
0	1	0	*	*	0	0	0	0	0	1	Small
0	1	0	*	*	0	0	0	0	1	0	
0	1	0	*	*	0	0	0	0	1	1	
							↓				↓
0	1	0	*	*	1	1	1	1	1	0	
0	1	0	*	*	1	1	1	1	1	1	Large

Note: *Inactive bit

7.18.3. The electronic volume register set sequence

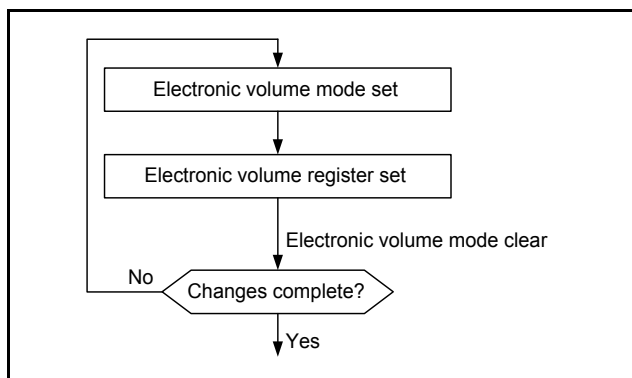

Figure 17

electrodes is connected to the FR terminal, and the other is connected to the FRS terminal. A different pattern is recommended for the static indicator electrodes than for the dynamic drive electrodes. If the pattern is too close, it can result in deterioration of the liquid crystal and of the electrodes. The static indicator ON command is a double byte command paired with the static indicator register set command, and thus one must execute one after the other. The static indicator OFF command is a single byte command.

7.19. Static Indicator (Double Byte Command)

This command controls the static drive system indicator display. The static indicator display is controlled by this command only, and is independent from other display control commands. This is used when one of the static indicator liquid crystal drive

7.19.1. Static indicator ON/OFF

When the static indicator ON command is entered, the static indicator register set command is enabled. Once the static indicator ON command is entered, no other command aside from the static indicator register set command can be used. This mode is cleared when data is set in the register by the static indicator register set command.

A0P	EP RD	RWP WR	DB7	DB6	DB5	DB4	DB3	DB2	DB1	DB0	Static Indicator
0	1	0	1	0	1	0	1	1	0	0	OFF
										1	ON

7.19.2. Static indicator register set

This command sets two bits of data into the static indicator register, and is used to set the static indicator into a blinking mode.

A0P	EP RD	RWP WR	DB7	DB6	DB5	DB4	DB3	DB2	DB1	DB0	Static Indicator
0	1	0	*	*	*	*	*	*	0	0	OFF
			*	*	*	*	*	*	0	1	ON (blinking at approximately one second intervals)
			*	*	*	*	*	*	1	0	ON (blinking at approximately 0.5 second intervals)
			*	*	*	*	*	*	1	1	ON (constantly on)

Note: *Disabled bit

7.20. Page Blinking (Double Byte Command)

7.20.1. The page blinking mode set

A0P	EP RD	RWP WR	DB7	DB6	DB5	DB4	DB3	DB2	DB1	DB0
0	1	0	1	1	0	1	0	1	0	1

7.20.2. Page blinking register set

Set either bit to '1' will set corresponding PAGE0 - PAGE7 to blink.

A0P	EP		DB7 DB6 DB5 DB4 DB3 DB2 DB1 DB0								Blinking Page	
	RD	WR										
0	1	0	1	0	0	0	0	0	0	0	0	PAGE 7 blink
			0	1	0	0	0	0	0	0	0	PAGE 6 blink
			0	0	1	0	0	0	0	0	0	PAGE 5 blink
			0	0	0	0	0	0	0	0	1	PAGE 0 blink

7.20.3. Page blinking indicator register set sequence

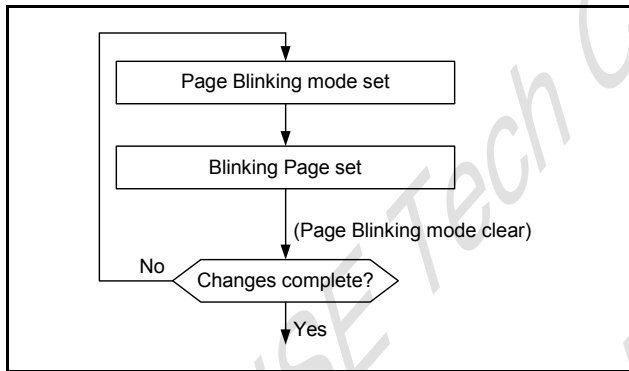

Figure 18

7.21. Set Driving Mode (Double Byte Command)

This command makes it possible to increase the V0 voltage stability by instruction command for using different liquid crystal panel. User can select the appropriate mode for their liquid crystal panel and display pattern. The V0 voltage stability is Mode2>Mode1(Default), and so as the current consumption.

7.21.1. The driving mode set

A0P	EP		DB7 DB6 DB5 DB4 DB3 DB2 DB1 DB0							
	RD	WR								
0	1	0	1	1	0	1	0	0	1	0

7.21.2. Mode selection register set

A0P	EP		DB7 DB6 DB5 DB4 DB3 DB2 DB1 DB0								Driving Duty Selection
	RD	WR									
0	1	0	0	0	0	0	0	0	0	0	Mode 1
			0	0	0	0	0	0	0	1	Mode 2

Note1: DB7 – DB1 7 bits must fill 0.

Note2: Mode1 DB0=0 is default.

Note3: Driving capability : MODE2 > MODE1.

7.22. Power Save (Compound Command)

When the display all points ON is performed while the display is in the OFF mode, the power saver mode is entered and therefore, it reduces a great amount of power. The power saver mode has two different modes: the sleep mode and the standby mode. When the static indicator is OFF, the sleep mode is entered. When the static indicator is ON, the standby mode is entered. In the sleep mode and standby mode, the display data is saved as is the operating mode that was in effect before the power saver mode was initiated, and the MPU is still able to access the display data RAM. Refer to figure 19 for power save off sequence.

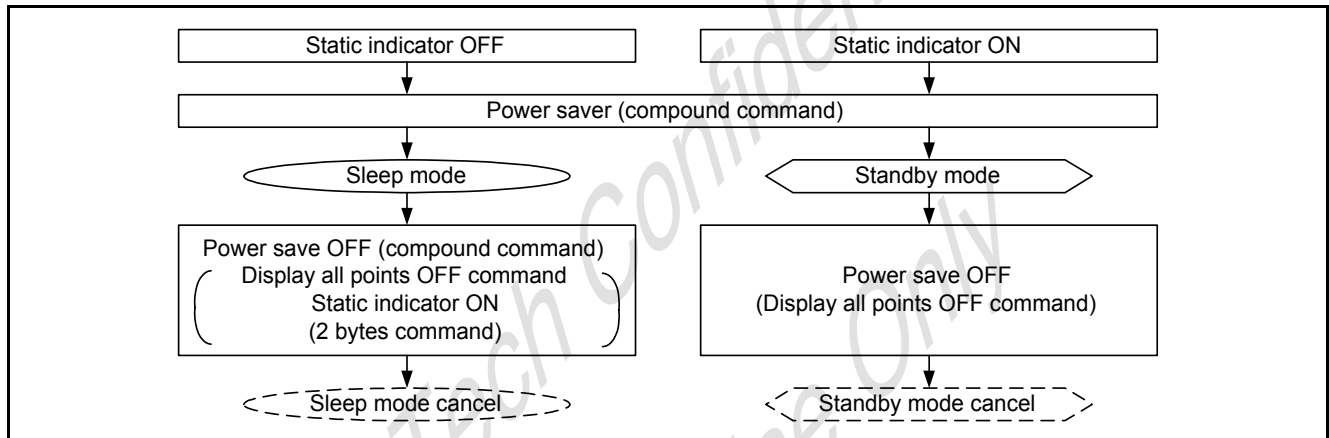

Figure 19

7.22.1. Sleep mode

This stops all operations in the LCD display system, and as long as there are no accesses from the MPU, the consumption current is reduced to a value close to the static current. The internal modes during sleep mode are as follows:

- 1). The oscillator circuit and the LCD power supply circuit are halted.
- 2). All liquid crystal drive circuits are halted, and the segment in common drive outputs output a VSS level.

7.22.2. Standby mode

The duty LCD display system operations are halted and only the static drive system for the indicator continues to operate, providing the minimum required consumption current for the static drive. The internal modes are in the following states during standby mode.

- 1). The LCD power supply circuits are halted. The oscillator circuit continues to operate.
- 2). The duty drive system liquid crystal drive circuits are halted and the segment and common driver outputs a VSS level. The static drive system does not operate.

When a reset command is performed while in standby mode, the system enters sleep mode.

Note1: When an external power supply is used, it is recommended that the functions of the external power supply circuit should be stopped when the power saver mode is started. For example, when the various levels of liquid crystal drive voltage are provided by external resistive voltage dividers, it is recommended that a circuit be added in order to cut the electrical current flowing through the resistive voltage divider circuit when the power saver mode is in effect. The SPLC502B chips have a liquid crystal display blanking control terminal DOF. This terminal enters a 'L' state when the power saver mode is launched. Using the output of DOF, it is possible to stop the function of an external power supply circuit.

Note2: When the master is turned on, the oscillator circuit is operable immediately after the power on.

7.23. NOP

Non-Operation Command

A0P	EP RD	RWP WR	DB7	DB6	DB5	DB4	DB3	DB2	DB1	DB0
0	1	0	1	1	1	0	0	0	1	1

7.24. TEST

This is a command for IC chip testing. Please do not use it. If applying a 'L' signal to the $\overline{\text{RESET}}$ input by the reset command the test command is used by accident, it can be cleared by or by using a NOP.

A0P	EP RD	RWP WR	DB7	DB6	DB5	DB4	DB3	DB2	DB1	DB0
0	1	0	1	1	1	1	*	*	*	*
0	1	0	1	1	0	1	0	0	1	0
0	1	0	1	1	0	1	0	1	0	0

Note: The SPLC502B chips maintain their operating modes until some conditions occurred to change them. Consequently, excessive external noise, etc., can change the internal modes of the SPLC502B chip. Thus, in the packaging and system design, it is necessary to suppress the noise or take measurement to prevent the noise from influencing the chip. Moreover, it is recommended that the operating modes be refreshed periodically to prevent the effects.

7.25. Oscillator Frequency selection

This is a command for Oscillator frequency selection of Driver IC.

A0P	EP RD	RWP WR	DB7	DB6	DB5	DB4	DB3	DB2	DB1	DB0	Static Indicator
0	1	0	1	1	1	0	0	1	0	0	20KHz/ 33KHz (default)
											16.4KHz/ 27.06KHz

7.26. Table 13 Table of SPLC502B Commands

Command	Command Code										Function	
	A0P	RD	WR	DB7	DB6	DB5	DB4	DB3	DB2	DB1		DB0
1). Display ON/OFF	0	1	0	1	0	1	0	1	1	1	0	LCD display ON/OFF 0: OFF, 1: ON
2). Display start line set	0	1	0	0	1	Display start address					Sets the display RAM display start line address	
3). Page address set	0	1	0	1	0	1	1	Page address				Sets the display RAM page address
4). Column address set upper bit	0	1	0	0	0	0	1	Most significant column address				Sets the most significant 4 bits of the display RAM column address.
Column address set lower bit	0	1	0	0	0	0	0	Least significant column address				Set the least significant 4 bits of the display RAM column address.
5). Status read	0	0	1	Status				0	0	0	0	Reads the status data
6). Display data write	1	1	0	Write data							Writes to the display RAM	
7). Display data read	1	0	1	Read data							Reads from the display RAM	
8). ADC select	0	1	0	1	0	1	0	0	0	0	0	Sets the display RAM address SEG output correspondence 0: normal, 1:reverse
9). Display normal/reverse	0	1	0	1	0	1	0	0	1	1	0	Sets the LCD display normal/ reverse 0: normal, 1:reverse
10). Display all points ON/OFF	0	1	0	1	0	1	0	0	1	0	0	Display all points 0: normal display 1: all points ON
11). LCD bias set	0	1	0	1	0	1	0	0	0	1	0	Sets the LCD driver voltage bias ratio SPLC502B.....0:1/9, 1:1/7
12). Read/modify/write	0	1	0	1	1	1	0	0	0	0	0	Column address increment At write: +1 At read: 0
13). End	0	1	0	1	1	1	0	1	1	1	0	Clear read/modify/write
14). Reset	0	1	0	1	1	1	0	0	0	1	0	Internal reset
15). Common output mode select	0	1	0	1	1	0	0	0	*	*	*	Select COM output scan direction 0: normal direction, 1: reverse direction
16). Power control set	0	1	0	0	0	1	0	1	Operating mode			Select internal power supply operating mode
17). V0 voltage regulator internal resistor ratio set	0	1	0	0	0	1	0	0	Resistor ratio			Select internal resistor ratio (Rb/Ra) mode
18). Electronic volume mode set	0	1	0	1	0	0	0	0	0	0	1	Set the V0 output voltage electronic volume register
Electronic volume register set	0	1	0	*	*	Electronic volume value						

Command	Command Code											Function
	AOP	RD	WR	DB7	DB6	DB5	DB4	DB3	DB2	DB1	DB0	
19). Static indicator ON/OFF	0	1	0	1	0	1	0	1	1	0	0	0: OFF, 1: ON
Static indicator Register set				*	*	*	*	*	*	Mode	1	Set the flashing mode
20). Page Blink	0	1	0	1	1	0	1	0	1	0	1	P7 - 0: 1 - blinking page 0 - no blinking, normal display
Page selection	0	1	0	P7	P6	P5	P4	P3	P2	P1	P0	
21). Driving Mode Set	0	1	0	1	1	0	1	0	0	1	0	Set the driving mode register
Mode selection	0	1	0	0	0	0	0	0	0	0	D0	Driving capability (D0): (1)>(0)
22). Power saver												Display OFF and display all points ON compound command
23). NOP	0	1	0	1	1	1	0	0	0	1	1	Command for non-operation
24). Test	0	1	0	1	1	1	1	*	*	*	*	Command for IC test. Do not use this command
				1	1	0	1	0	1	0	0	
25). Oscillator Frequency selection	0	1	0	1	1	1	0	0	1	0	0	20KHz/33KHz (Default)
											1	16.4KHz/ 27.06KHz

8. COMMAND DESCRIPTION

8.1. Instruction Setup: Reference (Reference)

8.1.1. Initialization

Note: When the power is applied, LCD driving non-selective potentials V₂ and V₃ (SEG pin) and V₁ and V₄ (COM pin) are output through the LCD driving output pins SEG and COM. When electric charge is remaining in the smoothing capacitor connecting between the LCD driving voltage output pins (V₀ . .) and the VDD pin, the picture on the display may become totally dark instantaneously when the power is turned on. To avoid occurrence of such a failure, we recommend the following flow when turning on the power.

1). When the built-in power is being used immediately after turning on the power:

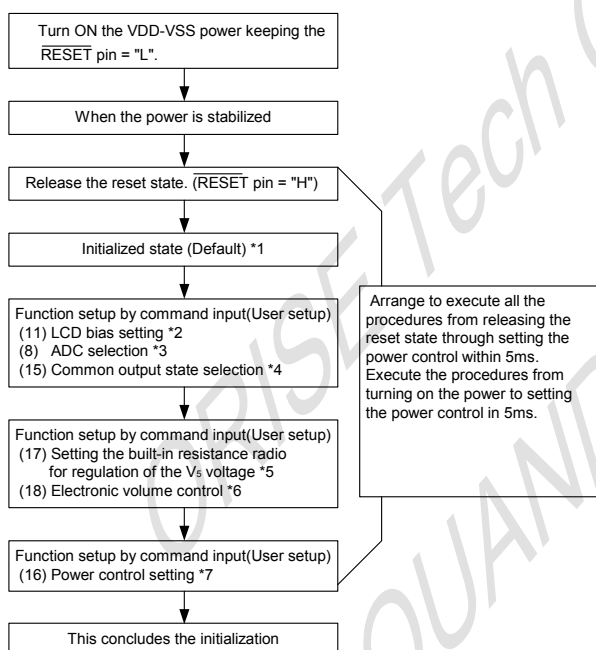

Figure 20

Note1: The target time of 5ms varied depending on the panel characteristics and the capacitance of the smoothing capacitor. Therefore, we suggest users to conduct an operation check using the actual equipment.

Note2: Refer to respective sections or paragraphs listed below.

- *1:Description of functions; Reset circuit
- *2:Command description; LCD bias setting
- *3:Command description; ADC selection
- *4:Command description; Common output state selection
- *5:Description of functions; Power circuit & Command description; Setting the built-in resistance ratio for regulation of the V₀ voltage
- *6:Description of functions; Power circuit & Command description; Electronic volume control
- *7:Description of functions; Power circuit & Command description; Power control setting.

2). When the built-in power is not being used immediately after turning on the power:

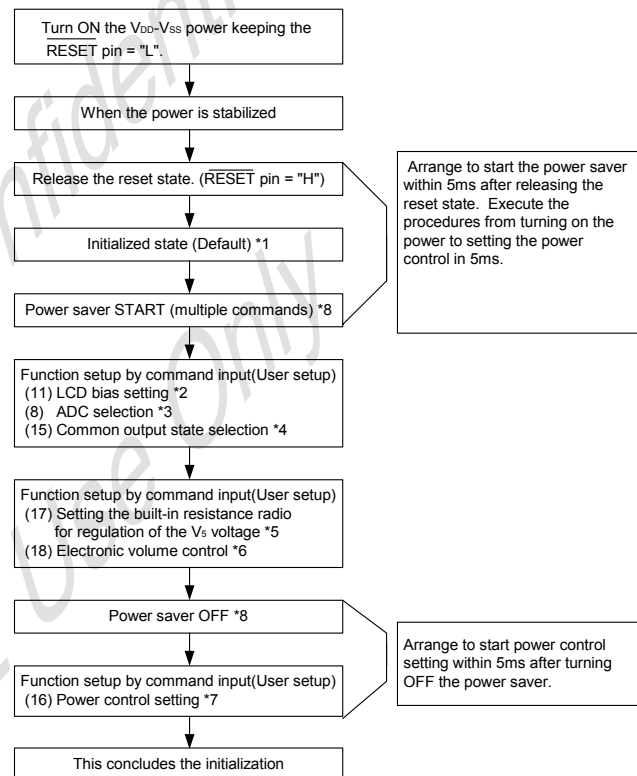

Figure 21

Note1: The target time of 5ms varied depending on the panel characteristics and the capacitance of the smoothing capacitor. Therefore, we suggest users to conduct an operation check using the actual equipment.

Note2: Refer to respective sections or paragraphs listed below.

- *1:Description of functions; Resetting circuit
- *2:Command description; LCD bias setting
- *3:Command description; ADC selection
- *4:Command description; Common output state selection
- *5:Description of functions; Power circuit & Command description; Setting the built-in resistance ratio for regulation of the V₀ voltage
- *6:Description of functions; Power circuit & Command description; Electronic volume control
- *7:Description of functions; Power circuit & Command description; Power control setting
- *8:The power saver ON state can either be in sleep state or stand-by state. Command description; Power saver START (multiple commands)

8.1.2. Data display

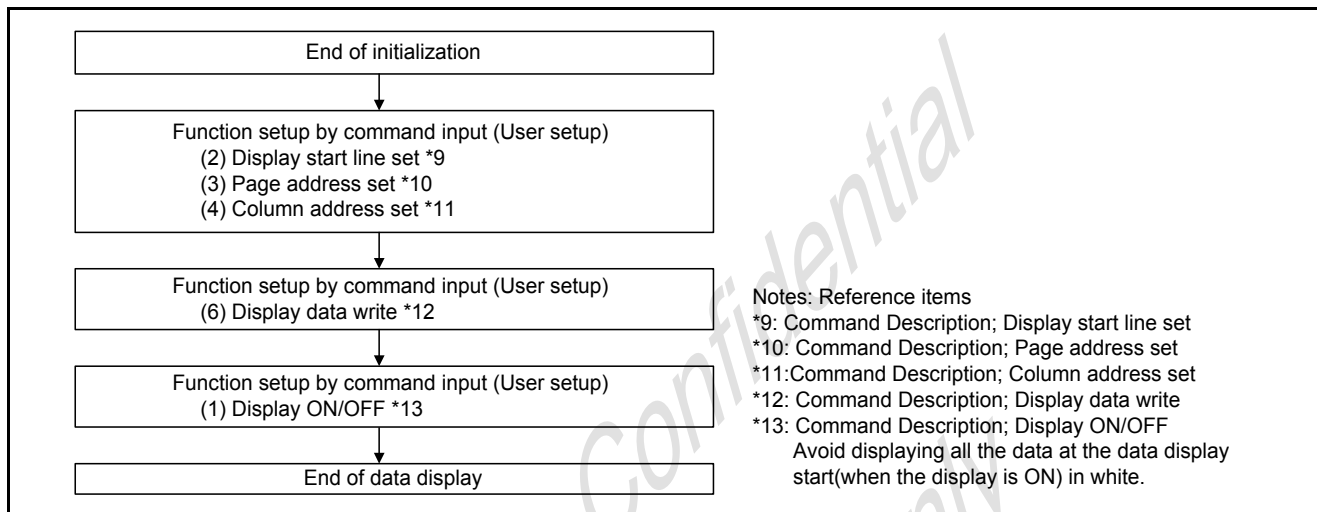

Figure 22

8.1.3. Power OFF *14

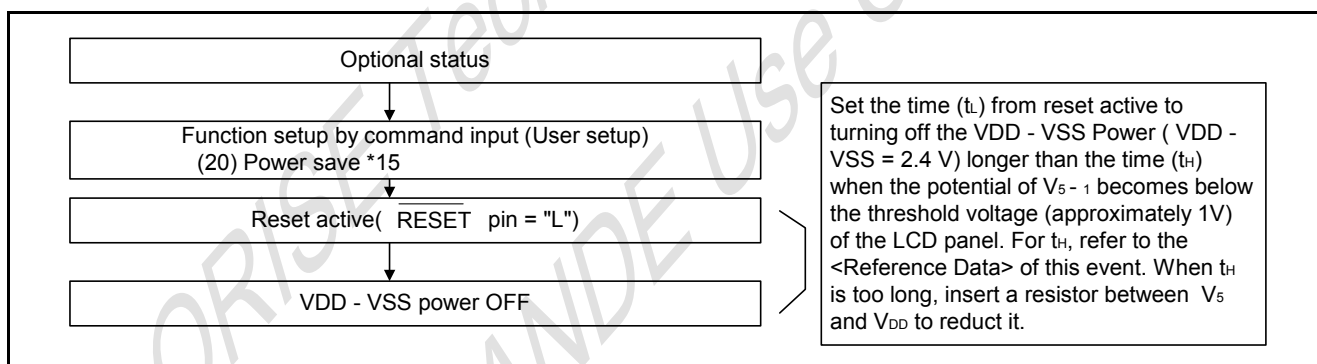

Figure 23

Note: Reference items

*14: The logic circuit of this IC's power supply VDD - VSS controls the driver of the LCD power supply V0. Therefore, if the power supply VDD - VSS is cut off when the LCD power supply V0 has still any residual voltage, the driver (COM. SEG) may output any uncontrolled voltage. When turning off the power, observe the following basic procedures:

- After turning off the internal power supply, make sure that the potential V_{0-1} has become below the threshold voltage of the LCD panel, and then turn off this IC's power supply (VDD - VSS).

Refer to "6. Description of Function, Power Circuit" for more information.

*15: After inputting the power save command, be sure to reset the function using the RESET terminal until the power supply VDD - VSS is turned off. Refer to "7. Command Description, (20) Power Save" for more information.

9. ELECTRICAL SPECIFICATIONS

9.1. Absolute Maximum Ratings

(Unless otherwise noted, VSS = 0V)

Parameter		Symbol	Conditions	Unit
Power Supply Voltage		VDD	-0.3 to + 3.6	V
Power supply voltage (2) (VDD standard)	With Triple step-up	VDD2	-0.3 to + 3.6	V
	With Quad step-up		-0.3 to + 3.6	
			-0.3 to + 3.0	
Power supply voltage (3) (VDD standard)		V ₀ , V _{LCD}	-0.3 to + 12	V
Power supply voltage (4) (VDD standard)		V ₁ , V ₂ , V ₃ , V ₄	-0.3 to V ₀	V
Input voltage		V _{IN}	-0.3 to VDD +0.3	V
Output voltage		V _O	-0.3 to VDD +0.3	V
Operating temperature		T _{OPR}	-20 to +75	°C
Storage temperature	Bare chip	T _{STR}	-55 to +125	°C

Notes and Cautions:

- The VDD2, V₀ to V₄ and V_{OUT} are relative to the VSS = 0V reference.
- Insure that the voltage levels of V₀, V₁, V₂, V₃, and V₄ are always such that V₀ ≥ V₁ ≥ V₂ ≥ V₃ ≥ V₄ ≥ VSS(GND)
- Permanent damage to the LSI may result if the LSI is used outside of the absolute maximum ratings. Moreover, it is recommended that in normal operation the chip be used at the electrical characteristic conditions, and use of the LSI outside of these conditions may not only result in malfunctions of the LSI, but may have a negative impact on the LSI reliability as well.

9.2. DC Characteristics

(Unless otherwise specified, VSS = 0V, VDD = 3.0V±10%, T_A = -20 to 75°C)

Item	Symbol	Condition	Rating			Units	Applicable PIN	
			Min.	Typ.	Max.			
Operating Voltage (1)	Recommended Voltage	VDD	1.8	-	3.6	V	VDD*1	
Operating Voltage (2)	Recommended Voltage	VDD2 (Relative to VSS)	1.8	-	3.6	V	VDD2	
Operating Voltage (3)	Possible Operating Voltage	V ₀ (Relative to VSS)	4.0	-	12.0	V	V ₀ *2	
High-level Input Voltage	V _{IHC}		0.8 x VDD	-	VDD	V	*3	
Low-level Input Voltage	V _{ILC}		VSS	-	0.2 x VDD	V	*3	
High-level output Voltage	V _{OHC}	I _{OH} = -0.5mA	0.8 x VDD	-	VDD	V	*4	
Low-level output Voltage	V _{OLC}	I _{OL} = 0.5mA	VSS	-	0.2 x VDD	V	*4	
Input leakage current	I _{LI}	V _{IN} = VDD or VSS	-1.0	-	1.0	μA	*5	
Output leakage current	I _{LO}		-3.0	-	3.0	μA	*6	
Liquid Crystal Driver ON Resistance	R _{ON}	T _A = 25°C	V ₀ = 12V	-	2.0	3.5	KΩ	SEg _n
		(Relative To VSS)	V ₀ = 8.0V	-	3.2	5.4	KΩ	COM _n *7
Static Consumption Current	I _{SSQ}		-	0.01	5.0	μA	VDD, VDD2	
Output Leakage Current	I _{OQ}	V ₀ = 12V (Relative to VSS)	-	0.01	15	μA	V ₀	
Input Terminal Capacitance		C _{IN}	T _A = 25°C f = 1.0MHz	-	5.0	8.0	pF	
Oscillator Frequency	Internal Oscillator	f _{OSC}	1/65 duty T _A = 25°C	17	20	23	KHz	*8
	External Input	f _{CL}	1/33 duty	17	20	23	KHz	CL
	Internal Oscillator	f _{OSC}	1/55 duty T _A = 25°C	28	33	38	KHz	*8
	External Input	f _{CL}	1/49 duty	28	33	38	KHz	CL

Item	Symbol	Condition		Rating			Units	Application PIN	
				Min.	Typ.	Max.			
Internal Power	Input Voltage	VDD2	With Triple (Relative to VSS)		1.8	-	4.0	V	VDD2
		VDD2	With Quad (Relative to VSS)		1.8	-	3.0	V	VDD2
	Supply Setup-up output voltage Circuit	V _{OUT}	(Relative to VSS)		-	-	13.0	V	V _{OUT}
	Voltage regulator Circuit Operating Voltage	V _{OUT}	(Relative to VSS)		4.0	-	13.0	V	V _{OUT}
	Voltage Follower Circuit Operating Voltage	V _O	(Relative to VSS)		4.0	-	12.0	V	V _O *9
Base Voltage	V _{REG0}	T _A = 25°C (Relative to VSS)	-0.05%/°C	2.08	2.1	2.12	V	*10	

9.3. Display Pattern Checker

(T_A = -20 to 75°C)

Item	Symbol	Condition		Rating			Units	Notes
				Min.	Typ.	Max.		
SPLC502B	I _{DD(1+2)}	VDD = 3.0V, V _O - VSS = 11V		-	20	25	μA	*11

Dynamic Consumption Current (1+2), During Display, with the Internal Power Supply OFF.
 Current consumed by total ICs when an external power supply is used.

9.4. Display Pattern Checker

(T_A = -20 to 75°C)

Item	Symbol	Condition		Rating			Units	Notes
				Min.	Typ.	Max.		
SPLC502B	I _{DD(1+2)}	VDD = 3.0V, Quad step-up voltage. V _O = 11.0V	Normal Mode	-	130	160	μA	*11

Dynamic Consumption Current (1+2), During Display, with the Internal Power Supply ON

Item	Symbol	Condition		Rating			Units	Notes
				Min.	Typ.	Max.		
Sleep Mode SPLC502B	I _{DDs1}	-		-	0.01	5.0	μA	

Item		f _{CL}	f _{FR}
1/65 DUTY *8	When the internal oscillator circuit is used (20KHz)	f _{OSC} / 4	f _{OSC} / (4 * 65)
	When the internal oscillator circuit is not used	External input (f _{CL})	f _{CL} / 260
1/55 DUTY *8	When the internal oscillator circuit is used (33KHz)	f _{OSC} / 8	f _{OSC} / (8 * 55)
	When the internal oscillator circuit is not used	External input (f _{CL})	f _{CL} / 220
1/49 DUTY *8	When the internal oscillator circuit is used (33KHz)	f _{OSC} / 8	f _{OSC} / (8 * 49)
	When the internal oscillator circuit is not used	External input (f _{CL})	f _{CL} / 196
1/33 DUTY *8	When the internal oscillator circuit is used (20KHz)	f _{OSC} / 8	f _{OSC} / (8 * 33)
	When the internal oscillator circuit is not used	External input (f _{CL})	f _{CL} / 264

References for items marked with *

- *1 While a broad range of operating voltages is guaranteed, performance cannot be guaranteed if there are sudden fluctuations to the voltage while the MPU is being accessed.
- *2 The operating voltage range for the VDD system and the V0 system is applied when the external power supply is being used.
- *3 The A0P, DB0 to DB5, DB6 (SCL), DB7 (SI), RD (EP), WR (RWP), CS1, CS2, CLS, CL, FR, MS, C86, PS, DOF, RES, and HPM terminals.
- *4 The DB0 to DB7, FR, FRS, DOF, and CL terminals.
- *5 The A0P, RD (EP), WR (RWP), CS1, CS2, CLS, MS, C86, PS, RES, and HPM terminals.

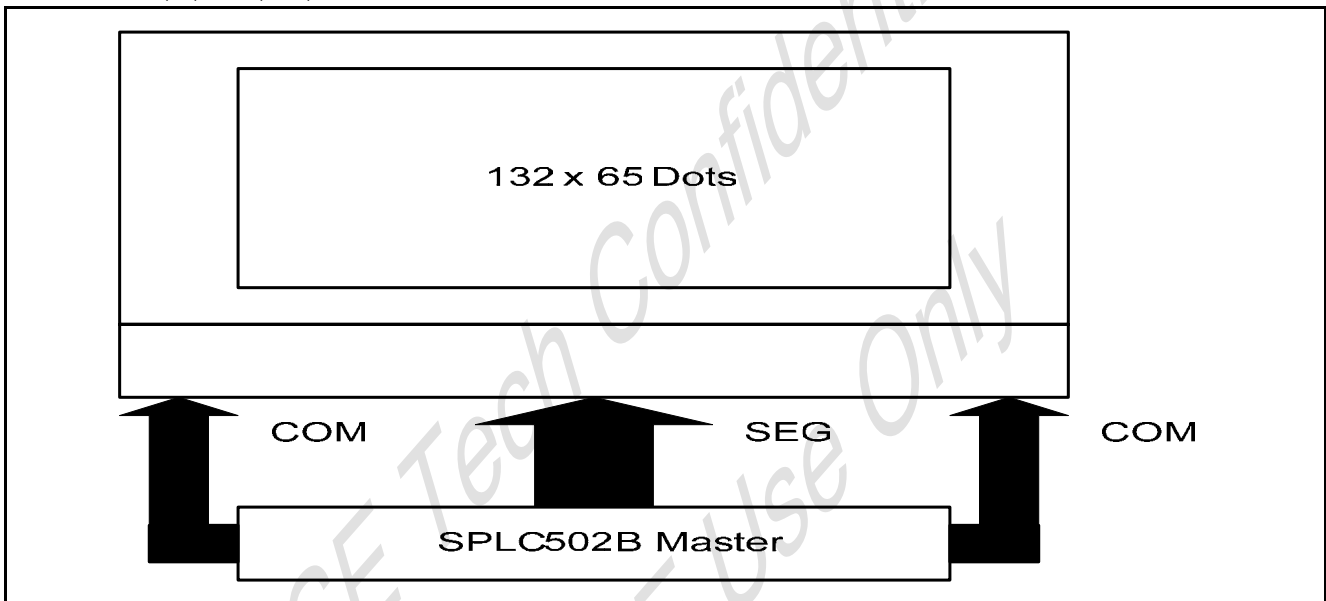

- *6 Applies when the DB0 to DB5, DB6 (SCL), DB7 (SI), CL, FR, and DOF terminals are in a high impedance state.
- *7 These are the resistance values for when a 0.1V voltage is applied between the output terminal SEG_n or COM_n and the various power supply terminals (V₁, V₂, V₃, and V₄). These are specified for the operating voltage (3) range.
 $R_{ON} = 0.1V / \Delta I$ (Where ΔI is the current that flows when 0.1V is applied while the power supply is ON.)
- *8 The relationship between the oscillator frequency and the frame rate frequency.
- *9 The V0 voltage regulator circuit regulates within the operating voltage range of the voltage follower.
- *10 This is the internal voltage reference supply for the V0 voltage regulator circuit. In the SPLC502B, the temperature range can come in three types as VREG options: (1) approximately $-0.05\%/C$.
- *11 It indicates the current consumed on ICs alone when the internal oscillator circuit and display are turned on.
 The SPLC502B is 1/9 biased. Does not include the current due to the LCD panel capacity and wiring capacity. Applicable only when there is no access from the MPU.
 V₁~V₄ without capacitor.
- *12 It is the value on a model having the V_{REG} option temperature gradient is $-0.05\%/C$ when the V0 voltage regulator internal resistor is used.

9.5. Timing Characteristics

9.5.1. System bus read/write characteristics 1 (For the 8080 Series MPU)

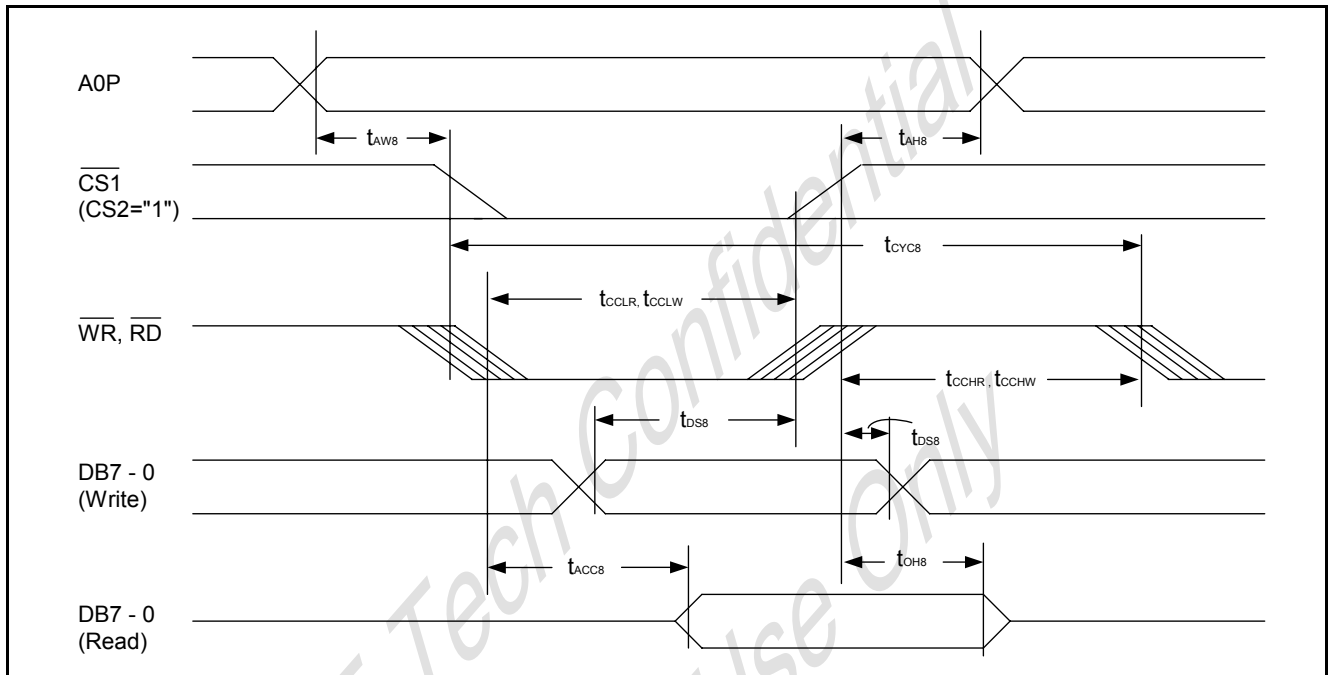

(VDD = 3.3V to 3.6V, T_A = -20 to 75°C)

Item	Signal	Symbol	Condition	Rating		Units
				Min.	Max.	
Address hold time	A0P	t _{AH8}		0	-	ns
Address setup time	A0P	t _{AW8}		0	-	ns
System cycle time	A0P	t _{CYC8}		240	-	ns
Control L pulse width (WR)	WR	t _{CCLW}		80	-	ns
Control L pulse width (RD)	RD	t _{CCLR}		80	-	ns
Control H pulse width (WR)	WR	t _{CCHW}		80	-	ns
Control H pulse width (RD)	RD	t _{CCHR}		80	-	ns
Data setup time	DB7 - 0	t _{DS8}		30	-	ns
Address hold time		t _{DH8}		10	-	ns
RD access time		t _{ACC8}	C _L = 100pF	-	70	ns
Output disable time		t _{OH8}		5.0	50	ns

(VDD = 2.7V to 3.3V, T_A = -20 to 75°C)

Item	Signal	Symbol	Condition	Rating		Units	
				Min.	Max.		
Address hold time	A0P	t _{AH8}		0	-	ns	
Address setup time		t _{AW8}		0	-	ns	
System cycle time	A0P	t _{CYC8}		400	-	ns	
Control L pulse width (<u>WR</u>)	<u>WR</u>	t _{CCLW}		100	-	ns	
Control L pulse width (<u>RD</u>)	<u>RD</u>	t _{CCLR}		100	-	ns	
Control H pulse width (<u>WR</u>)	<u>WR</u>	t _{CCHW}		100	-	ns	
Control H pulse width (<u>RD</u>)	<u>RD</u>	t _{CCHR}		100	-	ns	
Data setup time	DB7 - 0	t _{DS8}		40	-	ns	
Address hold time		t _{DH8}		15	-	ns	
RD access time		t _{ACC8}	C _L = 100pF		-	140	ns
Output disable time		t _{OH8}			10	100	ns

(VDD = 1.8V to 2.7V, T_A = -20 to 75°C)

Item	Signal	Symbol	Condition	Rating		Units	
				Min.	Max.		
Address hold time	A0P	t _{AH8}		0	-	ns	
Address setup time		t _{AW8}		0	-	ns	
System cycle time	A0P	t _{CYC8}		640	-	ns	
Control L pulse width (<u>WR</u>)	<u>WR</u>	t _{CCLW}		200	-	ns	
Control L pulse width (<u>RD</u>)	<u>RD</u>	t _{CCLR}		200	-	ns	
Control H pulse width (<u>WR</u>)	<u>WR</u>	t _{CCHW}		200	-	ns	
Control H pulse width (<u>RD</u>)	<u>RD</u>	t _{CCHR}		200	-	ns	
Data setup time	DB7 - 0	t _{DS8}		80	-	ns	
Address hold time		t _{DH8}		30	-	ns	
RD access time		t _{ACC8}	C _L = 100pF		-	280	ns
Output disable time		t _{OH8}			10	200	ns

Note1: The input signal rise time and fall time (t_r, t_f) is specified at 15 ns or less. When the system cycle time is extremely fast, (t_r + t_f) ≤ (t_{CYC8} - t_{CCLW} - t_{CCHW}) for (t_r + t_f) ≤ (t_{CYC8} - t_{CCLR} - t_{CCHR}) are specified.

Note2: All timing is specified using 20% and 80% of VDD as the reference.

Note3: t_{CCLW} and t_{CCLR} are specified as the overlap between CS1 being 'L' (CS2 = 'H') and WR and RD being at the 'L' level.

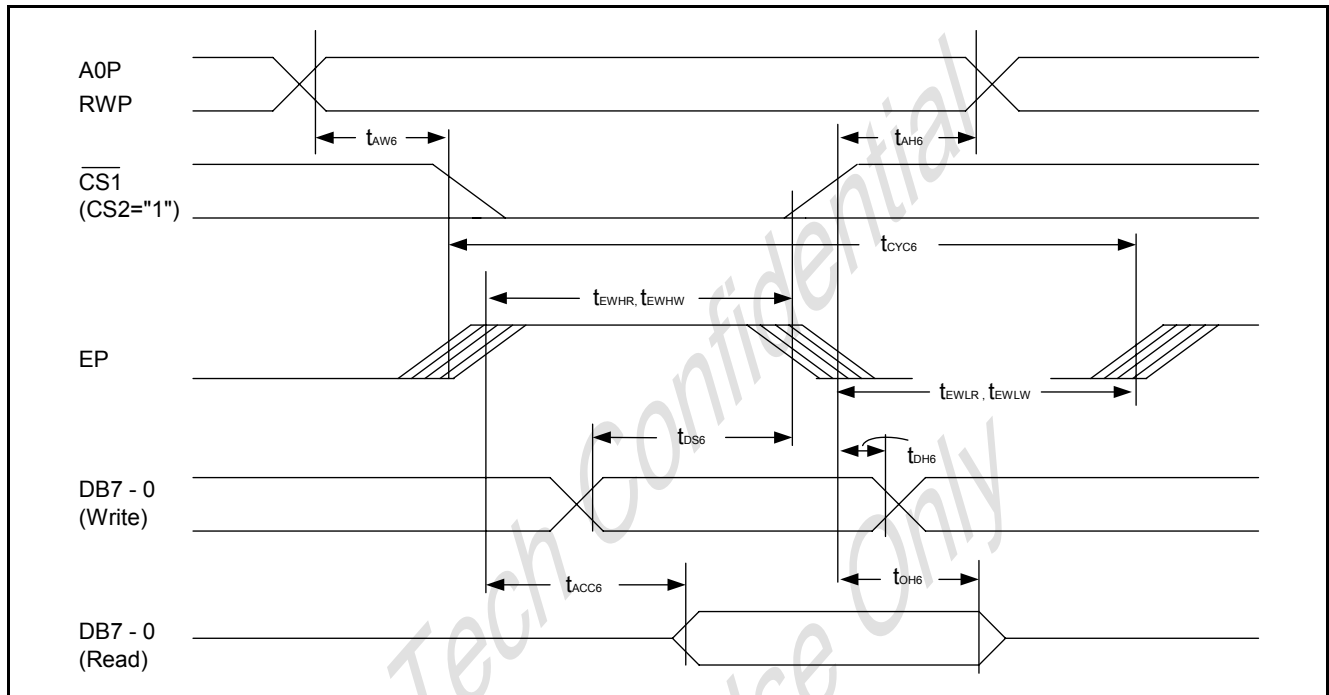
9.5.2. System bus read/write characteristics 2 (6800 series MPU)

 (VDD = 3.3V to 3.6V, T_A = -20 to 75°C)

Item	Signal	Symbol	Condition	Rating		Units
				Min.	Max.	
Address hold time	A0P	t _{AH6}		0	-	ns
Address setup time	A0P	t _{AW6}		0	-	ns
System cycle time	A0P	t _{CYC6}		240	-	ns
Data setup time	DB7 - 0	t _{DS6}	C _L = 100pF	30	-	ns
Data hold time		t _{DH6}		10	-	ns
Access time	DB7 - 0	t _{ACC6}		-	70	ns
Output disable time		t _{OH6}		10	50	ns
Enable H pulse time	Read	EP	t _{EWHR}	80	-	ns
	Write		t _{EWHW}	80	-	ns
Enable L pulse time	Read	EP	t _{EWLR}	80	-	ns
	Write		t _{EWLW}	80	-	ns

(VDD = 2.7V to 3.3V, T_A = -20 to 75°C)

Item	Signal	Symbol	Condition	Rating		Units	
				Min.	Max.		
Address hold time	A0P	t _{AH6}		0	-	ns	
Address setup time		t _{AW6}		0	-	ns	
System cycle time	A0P	t _{CYC6}		400	-	ns	
Data setup time	DB7 - 0	t _{DS6}	C _L = 100pF	40	-	ns	
Data hold time		t _{DH6}		15	-	ns	
Access time		t _{ACC6}		-	140	ns	
Output disable time		t _{OH6}		10	100	ns	
Enable H pulse time	Read	EP		t _{EWHR}	100	-	ns
	Write			t _{EWHW}	100	-	ns
Enable L pulse time	Read	EP		t _{EWLR}	100	-	ns
	Write			t _{EWLW}	100	-	ns

(VDD = 1.8V to 2.7V, T_A = -20 to 75°C)

Item	Signal	Symbol	Condition	Rating		Units	
				Min.	Max.		
Address hold time	A0P	t _{AH6}		0	-	ns	
Address setup time		t _{AW6}		0	-	ns	
System cycle time	A0P	t _{CYC6}		640	-	ns	
Data setup time	DB7 - 0	t _{DS6}	C _L = 100pF	80	-	ns	
Data hold time		t _{DH6}		30	-	ns	
Access time		t _{ACC6}		-	280	ns	
Output disable time		t _{OH6}		10	120	ns	
Enable H pulse time	Read	EP		t _{EWHR}	200	-	ns
	Write			t _{EWHW}	200	-	ns
Enable L pulse time	Read	EP		t _{EWLR}	200	-	ns
	Write			t _{EWLW}	200	-	ns

Note1: The input signal rise time and fall time (t_r, t_f) is specified at 15 ns or less. When the system cycle time is extremely fast, (t_r + t_f) ≤ (t_{CYC6} - t_{EWLW} - t_{EWHR}) for (t_r + t_f) ≤ (t_{CYC6} - t_{EWLW} - t_{EWHR}) are specified.

Note2: All timing is specified using 20% and 80% of VDD as the reference.

Note3: t_{EWLW} and t_{EWLR} are specified as the overlap between CS1 being 'L' (CS2 = 'H') and EP.

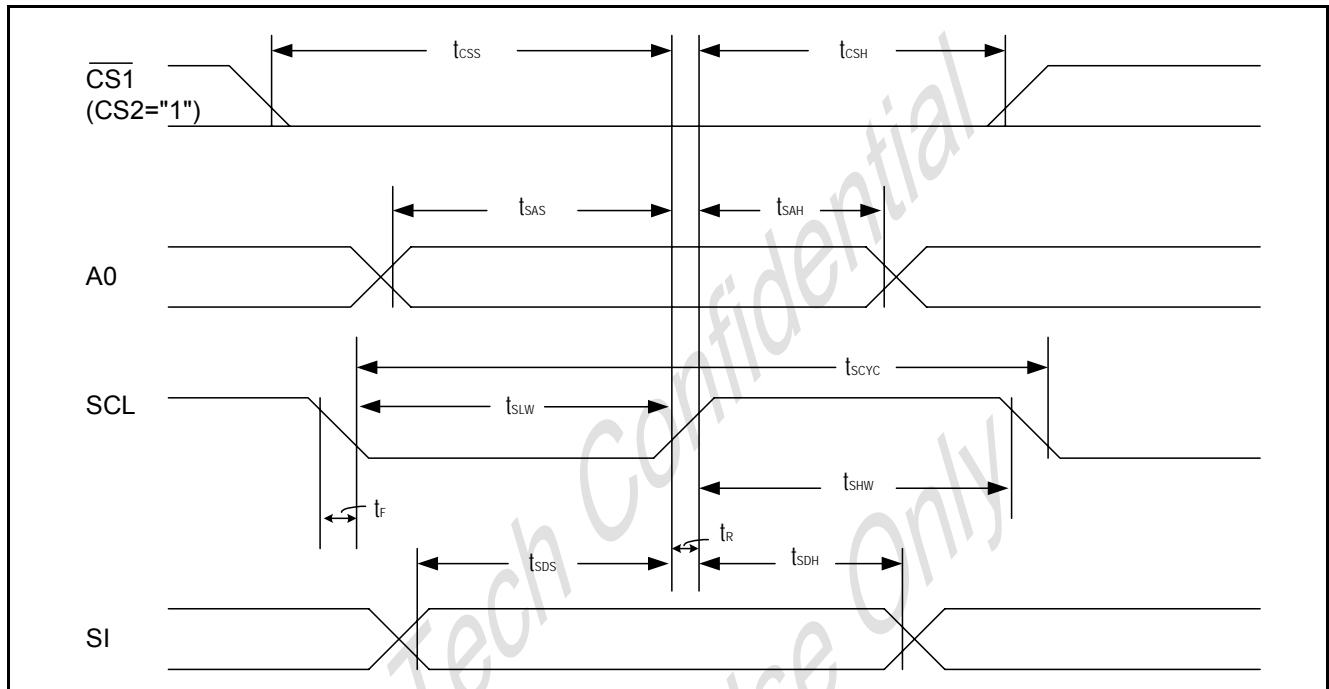
9.5.3. The serial interface

 (VDD = 3.3V to 3.6V, T_A = -20 to 75°C)

Item	Signal	Symbol	Condition	Rating		Units
				Min.	Max.	
Serial Clock Period		t _{SCYC}	-	200	-	ns
SCL 'H' pulse width	SCL	t _{SHW}	-	80	-	ns
SCL 'L' pulse width		t _{SLW}	-	80	-	ns
Address setup time		t _{SAS}	-	50	-	ns
Address hold time	A0P	t _{SAH}	-	100	-	ns
Data setup time		t _{SDS}	-	50	-	ns
Data hold time	SI	t _{SDH}	-	50	-	ns
CS-SCL time	CS	t _{CSS}	-	100	-	ns
		t _{CSH}	-	100	-	ns

 (VDD = 2.7V to 3.3V, T_A = -20 to 75°C)

Item	Signal	Symbol	Condition	Rating		Units
				Min.	Max.	
Serial Clock Period		t _{SCYC}	-	250	-	ns
SCL 'H' pulse width	SCL	t _{SHW}	-	100	-	ns
SCL 'L' pulse width		t _{SLW}	-	100	-	ns
Address setup time		t _{SAS}	-	150	-	ns
Address hold time	A0P	t _{SAH}	-	150	-	ns
Data setup time		t _{SDS}	-	100	-	ns
Data hold time	SI	t _{SDH}	-	100	-	ns
CS-SCL time	CS	t _{CSS}	-	150	-	ns
		t _{CSH}	-	150	-	ns

(VDD = 1.8V to 2.7V, TA = -20 to 75°C)

Item	Signal	Symbol	Condition	Rating		Units
				Min.	Max.	
Serial Clock Period	SCL	t_{SCYC}	-	350	-	ns
SCL 'H' pulse width		t_{SHW}	-	150	-	ns
SCL 'L' pulse width		t_{SLW}	-	150	-	ns
Address setup time	A0P	t_{SAS}	-	150	-	ns
Address hold time		t_{SAH}	-	150	-	ns
Data setup time	SI	t_{SDS}	-	60	-	ns
Data hold time		t_{SDH}	-	30	-	ns
CS-SCL time	CS	t_{CSS}	-	250	-	ns
		t_{CSH}	-	250	-	ns

Note1: The input signal rise and fall time (t_r , t_f) are specified at 15 ns or less.

Note2: All timing is specified using 20% and 80% of VDD as the standard.

9.5.4. Display control output timing

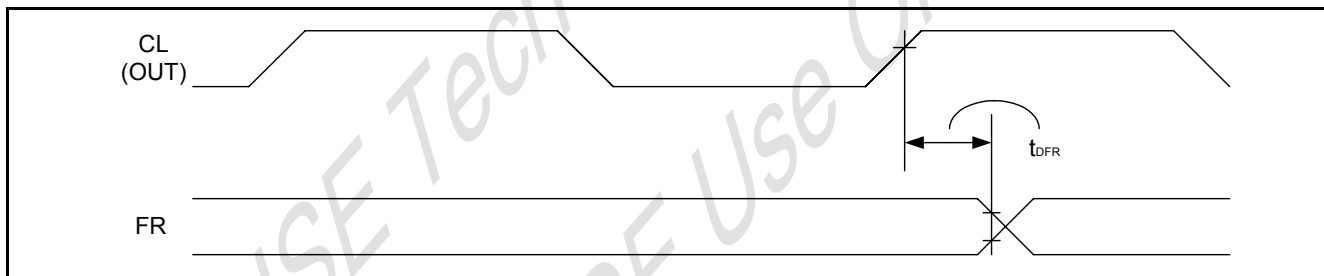

(VDD = 3.3V to 3.6V, TA = -20 to 75°C)

Item	Signal	Symbol	Condition	Rating			Units
				Min.	Typ.	Max.	
FR delay time	FR	t_{DFR}	$C_L = 50\text{pF}$	-	10	40	ns

(VDD = 2.7V to 3.3V, TA = -20 to 75°C)

Item	Signal	Symbol	Condition	Rating			Units
				Min.	Typ.	Max.	
FR delay time	FR	t_{DFR}	$C_L = 50\text{pF}$	-	20	80	ns

(VDD = 1.8V to 2.7V, TA = -20 to 75°C)

Item	Signal	Symbol	Condition	Rating			Units
				Min.	Typ.	Max.	
FR delay time	FR	t_{DFR}	$C_L = 50\text{pF}$	-	50	200	ns

Note1: Valid only when the master mode is selected.

Note2: All timing is based on 20% and 80% of VDD.

9.5.5. Reset timing

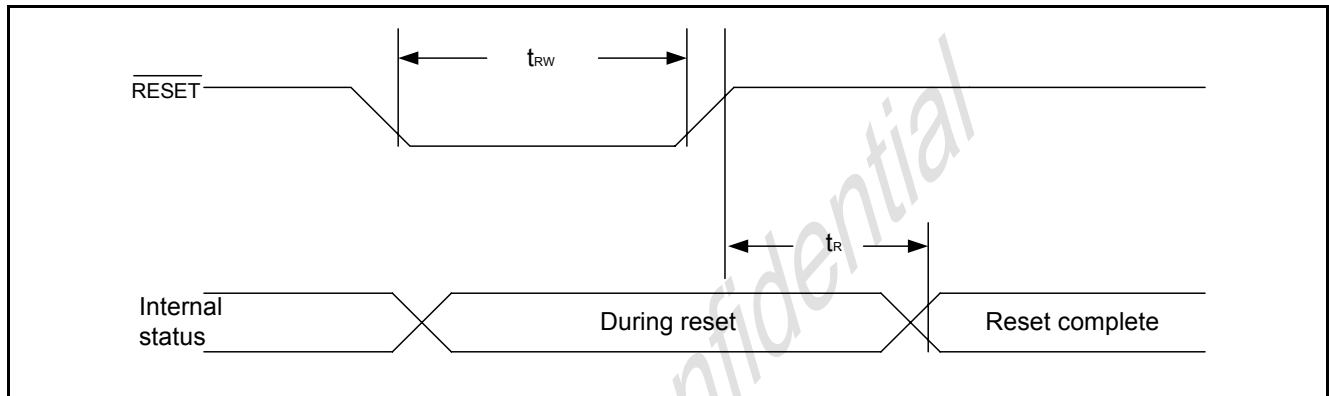

(VDD = 3.3 V to 3.6V, T_A = -20 to 75°C)

Item	Signal	Symbol	Condition	Rating			Units
				Min.	Typ.	Max.	
Reset time		t _R	-	-	-	0.5	μs
Reset 'L' pulse width	RES	t _{RW}	-	0.5	-	-	μs

(VDD = 2.7V to 3.3V, T_A = -20 to 75°C)

Item	Signal	Symbol	Condition	Rating			Units
				Min.	Typ.	Max.	
Reset time		t _R	-	-	-	1.0	μs
Reset 'L' pulse width	RES	t _{RW}	-	1.0	-	-	μs

(VDD = 1.8V to 2.7V, T_A = -20 to 75°C)

Item	Signal	Symbol	Condition	Rating			Units
				Min.	Typ.	Max.	
Reset time		t _R	-	-	-	1.5	μs
Reset 'L' pulse width	RES	t	-	1.5	-	-	μs

Note: All timing is specified with 20% and 80% of VDD as the standard.

9.6. The MPU Interface (Reference Examples)

The SPLC502B can be connected to either 80X86 Series MPUs or to 68000 Series MPUs. Moreover, The serial interface is possible to operate the SPLC502B chips with fewer signal lines. The

display area can be enlarged by using multiple SPLC502B chips. When this is done, the chip select signal can be used to select the individual ICs to access.

9.6.1. 8080 series MPUs

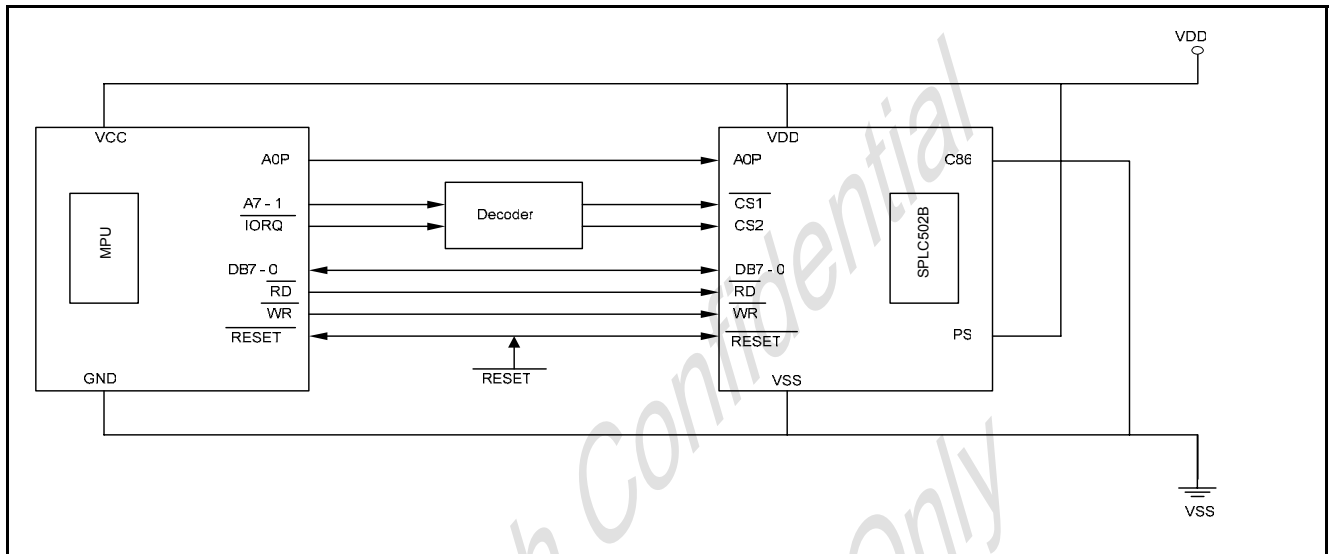

Figure 26

9.6.2. 6800 series MPUs

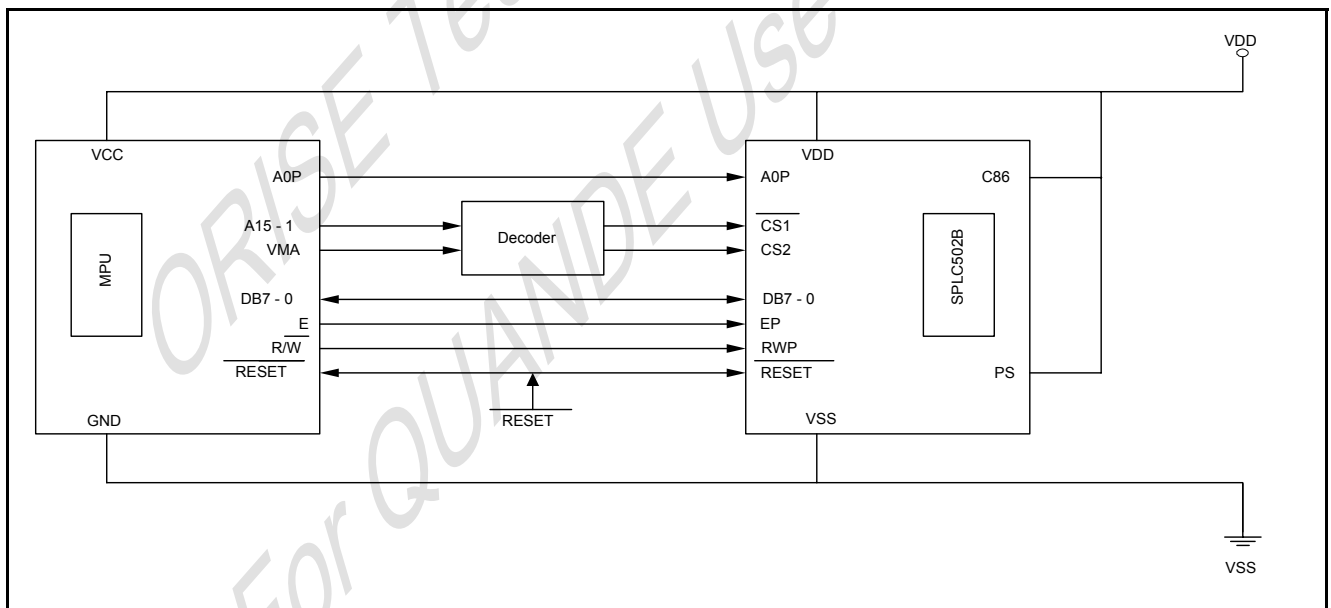

Figure 27

9.6.3. Using the serial interface

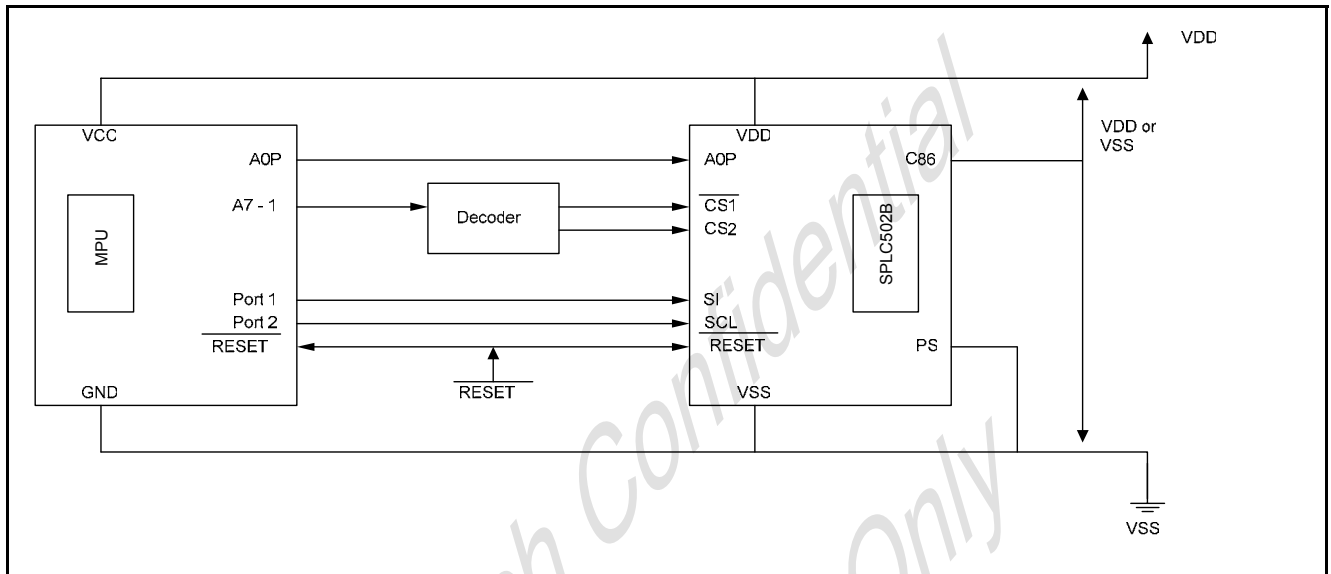

Figure 28

9.7. Connections between LCD Drivers (Reference Example)

The liquid crystal display area can be enlarged with ease through the use of multiple SPLC502B chips. Use a same equipment type.

9.7.1. SPLC502B (Master) <-> SPLC502B (Slave)

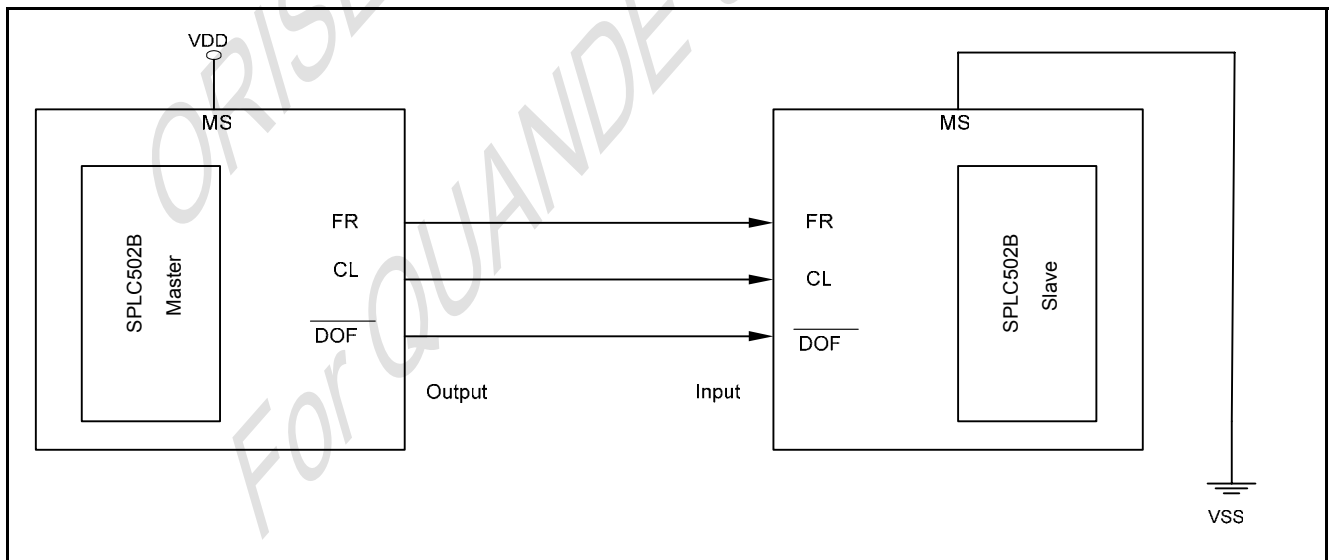
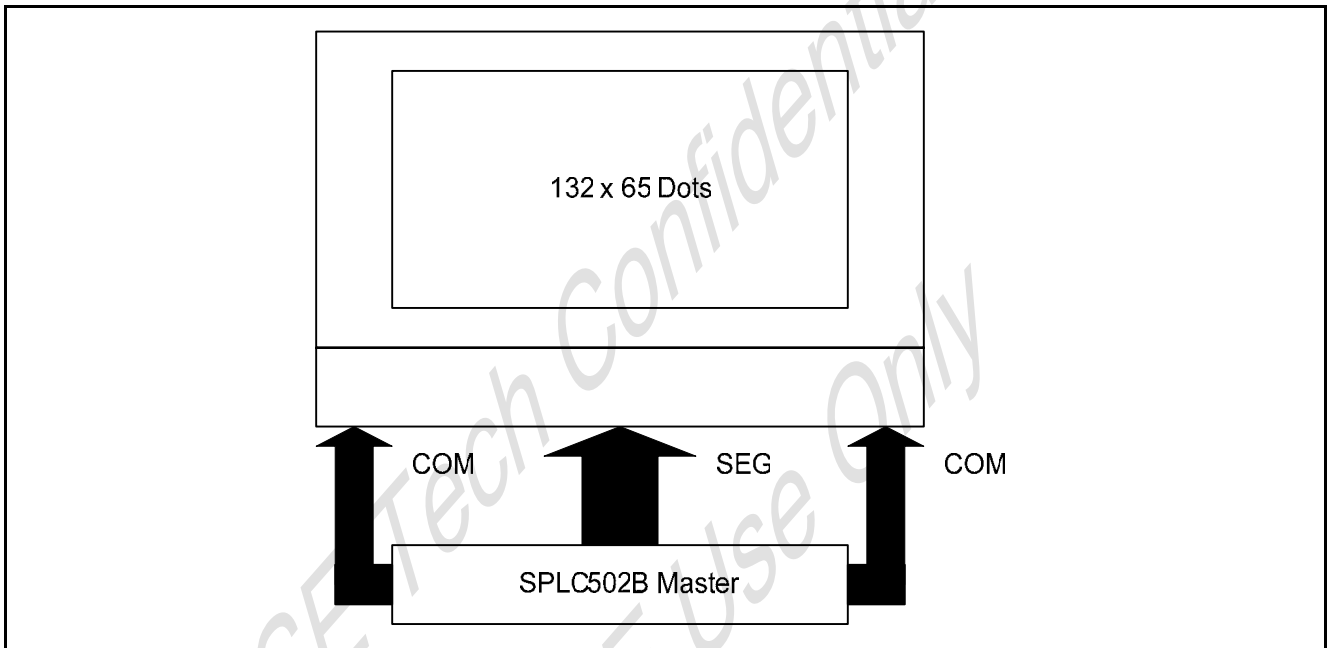

Figure 29

9.8. Connections between LCD Drivers (Reference Examples)

The liquid crystal display area can be enlarged with ease through the use of multiple SPLC502B chips. Use a same equipment type, in the composition of these chips.



9.8.1. Single-chip structure

Figure 30

9.8.2. Double-chip structure

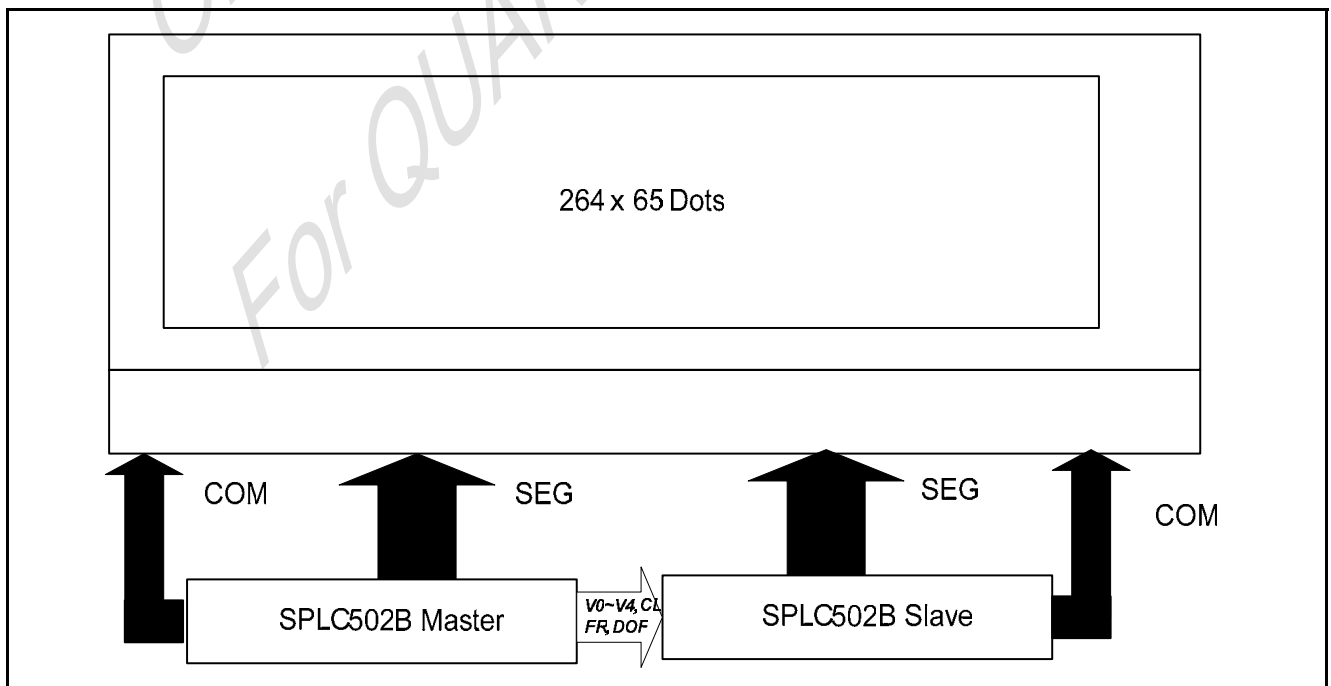
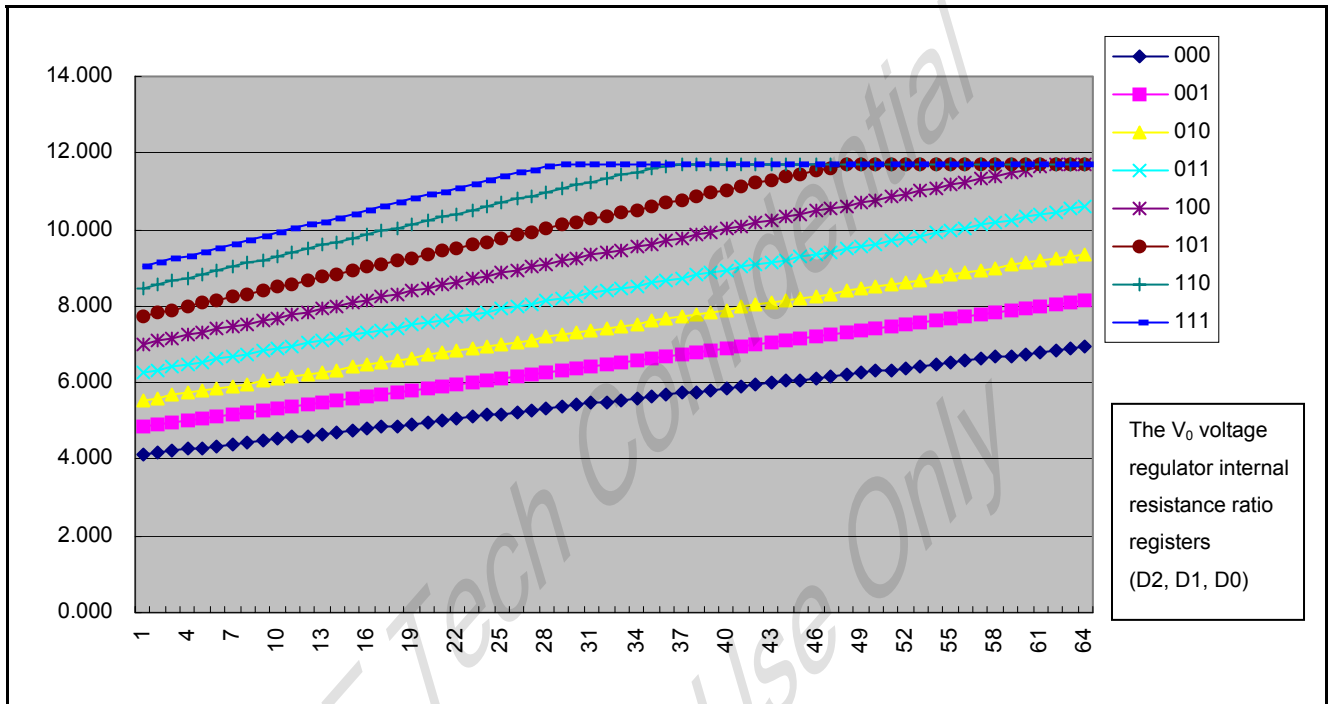

Figure 31

10. VLCD Voltage (Voltage between V0 to VSS) relationship of V0 Voltage Regulator Internal Resistor Ratio Register and Electronic Volume Control Register



Note: Use External V_{OUT} Power Supply.

11. CHIP INFORMATION

11.1. PAD Assignment

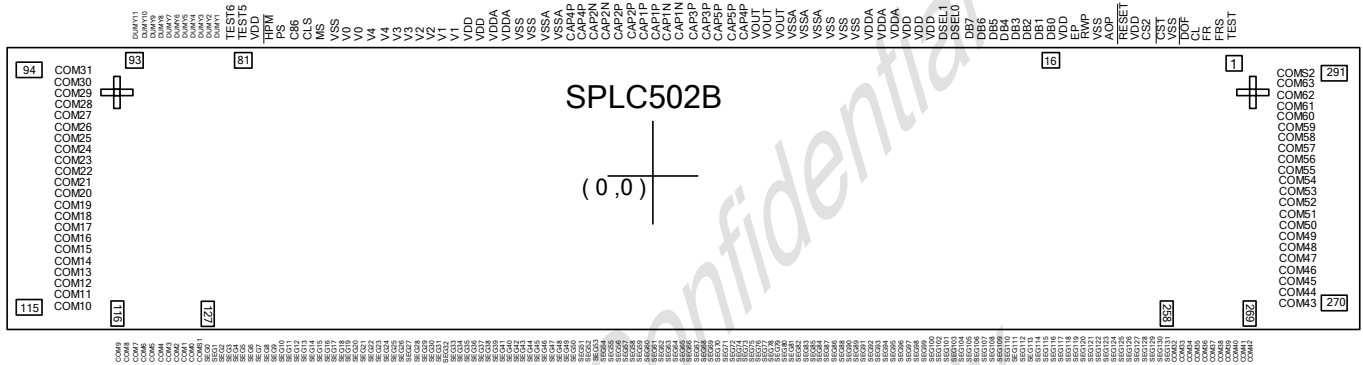

11.2. PAD Dimension

Item	PAD No.	Size		Unit
		X	Y	
Chip Size	-	5965	930	μm
Chip thickness	-	483 ± 25μm		
Pad pitch	1 ~ 82	55		
	83 ~ 93 (Test Pins)	40		
	94 ~ 115	34		
	270 ~ 291	34		
Bumped pad size	1 ~ 82	40	100	
	83 ~ 93	25	63.6	
	94 ~ 115	135	19	
	270 ~ 291	19	135	

Note1: Chip size included scribe line.

Note2: To ensure that the IC functions properly, please bond all of VDD, VSS, AVDD and AVSS pins.

Note3: The 0.1μF capacitor between VDD and VSS should be placed to IC as close as possible.

11.3. Bump Characteristic

Item	Standard	Note
Bump Hardness	50HV	±15HV
Bump Height	18μm	±3μm
Co-planarity (in Chip)	$R \leq 2\mu m$	R : Max-Min
Roughness (in Bump)	$R \leq 2\mu m$	R : Max-Min
Bump Size	"X" ± 4μm x "Y" ± 4μm	X/Y: bump size
Shear Force	>4.5g/mil ²	

11.4. PAD Locations

PAD No.	PAD Name	X	Y
1	TEST	2552.84	344.15
2	FRS	2497.84	344.15
3	FR	2442.84	344.15
4	CL	2387.84	344.15
5	$\overline{\text{DOF}}$	2332.84	344.15
6	VSS	2277.84	344.15
7	$\overline{\text{CS1}}$	2222.84	344.15
8	CS2	2167.84	344.15
9	VDD	2112.84	344.15
10	$\overline{\text{RESET}}$	2057.84	344.15
11	A0P	2002.84	344.15
12	VSS	1947.84	344.15
13	RWP	1892.84	344.15
14	EP	1837.84	344.15
15	VDD	1782.73	344.15
16	DB0	1727.84	344.15
17	DB1	1672.84	344.15
18	DB2	1617.84	344.15
19	DB3	1562.84	344.15
20	DB4	1507.84	344.15
21	DB5	1452.84	344.15
22	DB6	1397.84	344.15
23	DB7	1342.84	344.15
24	DSEL0	1287.84	344.15
25	DSEL1	1232.84	344.15
26	VDD	1177.84	344.15
27	VDD	1122.84	344.15
28	VDD	1067.84	344.15
29	VDDA	1012.84	344.15
30	VDDA	957.84	344.15
31	VDDA	902.84	344.15
32	VSS	847.84	344.15
33	VSS	792.84	344.15
34	VSS	737.84	344.15
35	VSSA	682.84	344.15
36	VSSA	627.84	344.15
37	VSSA	572.84	344.15
38	VOUT	517.84	344.15
39	VOUT	462.84	344.15
40	VOUT	407.84	344.15
41	CAP4P	352.84	344.15
42	CAP5P	297.84	344.15
43	CAP5P	242.84	344.15
44	CAP3P	187.84	344.15
45	CAP3P	132.84	344.15
46	CAP1N	68.57	344.15
47	CAP1N	13.57	344.15
48	CAP1P	-50.68	344.15

PAD No.	PAD Name	X	Y
49	CAP1P	-105.68	344.15
50	CAP2P	-160.68	344.15
51	CAP2P	-215.68	344.15
52	CAP2N	-279.95	344.15
53	CAP2N	-334.95	344.15
54	CAP4P	-399.2	344.15
55	CAP4P	-454.2	344.15
56	VSSA	-509.2	344.15
57	VSSA	-564.2	344.15
58	VSS	-619.2	344.15
59	VSS	-674.2	344.15
60	VDDA	-729.2	344.15
61	VDDA	-784.2	344.15
62	VDD	-841	344.15
63	VDD	-896	344.15
64	V1	-955.54	344.15
65	V1	-1010.54	344.15
66	V2	-1065.54	344.15
67	V2	-1120.54	344.15
68	V3	-1175.54	344.15
69	V3	-1230.54	344.15
70	V4	-1285.54	344.15
71	V4	-1340.54	344.15
72	V0	-1395.54	344.15
73	V0	-1450.54	344.15
74	VSS	-1505.54	344.15
75	MS	-1560.54	344.15
76	CLS	-1615.54	344.15
77	C86	-1670.54	344.15
78	PS	-1725.54	344.15
79	$\overline{\text{HPM}}$	-1780.54	344.15
80	VDD	-1835.54	344.15
81	TEST5	-1890.55	344.15
82	TEST6	-1945.55	344.15
83	DUMY1	-2018.99	362.35
84	DUMY2	-2058.99	362.35
85	DUMY3	-2098.99	362.35
86	DUMY4	-2138.99	362.35
87	DUMY5	-2178.99	362.35
88	DUMY6	-2218.99	362.35
89	DUMY7	-2258.99	362.35
90	DUMY8	-2298.99	362.35
91	DUMY9	-2338.99	362.35
92	DUMY10	-2378.99	362.35
93	DUMY11	-2421.1	362.35
94	COM31	-2846.45	357
95	COM30	-2846.45	323
96	COM29	-2846.45	289

PAD No.	PAD Name	X	Y
97	COM28	-2846.45	255
98	COM27	-2846.45	221
99	COM26	-2846.45	187
100	COM25	-2846.45	153
101	COM24	-2846.45	119
102	COM23	-2846.45	85
103	COM22	-2846.45	51
104	COM21	-2846.45	17
105	COM20	-2846.45	-17
106	COM19	-2846.45	-51
107	COM18	-2846.45	-85
108	COM17	-2846.45	-119
109	COM16	-2846.45	-153
110	COM15	-2846.45	-187
111	COM14	-2846.45	-221
112	COM13	-2846.45	-255
113	COM12	-2846.45	-289
114	COM11	-2846.45	-323
115	COM10	-2846.45	-357
116	COM9	-2601.32	-328.95
117	COM8	-2567.32	-328.95
118	COM7	-2533.32	-328.95
119	COM6	-2499.32	-328.95
120	COM5	-2465.32	-328.95
121	COM4	-2431.32	-328.95
122	COM3	-2397.32	-328.95
123	COM2	-2363.32	-328.95
124	COM1	-2329.32	-328.95
125	COM0	-2295.32	-328.95
126	COMS1	-2261.32	-328.95
127	SEG0	-2227.32	-328.95
128	SEG1	-2193.32	-328.95
129	SEG2	-2159.32	-328.95
130	SEG3	-2125.32	-328.95
131	SEG4	-2091.32	-328.95
132	SEG5	-2057.32	-328.95
133	SEG6	-2023.32	-328.95
134	SEG7	-1989.32	-328.95
135	SEG8	-1955.32	-328.95
136	SEG9	-1921.32	-328.95
137	SEG10	-1887.32	-328.95
138	SEG11	-1853.32	-328.95
139	SEG12	-1819.32	-328.95
140	SEG13	-1785.32	-328.95
141	SEG14	-1751.32	-328.95
142	SEG15	-1717.32	-328.95
143	SEG16	-1683.32	-328.95
144	SEG17	-1649.32	-328.95
145	SEG18	-1615.32	-328.95
146	SEG19	-1581.32	-328.95

PAD No.	PAD Name	X	Y
147	SEG20	-1547.32	-328.95
148	SEG21	-1513.32	-328.95
149	SEG22	-1479.32	-328.95
150	SEG23	-1445.32	-328.95
151	SEG24	-1411.32	-328.95
152	SEG25	-1377.32	-328.95
153	SEG26	-1343.32	-328.95
154	SEG27	-1309.32	-328.95
155	SEG28	-1275.32	-328.95
156	SEG29	-1241.32	-328.95
157	SEG30	-1207.32	-328.95
158	SEG31	-1173.32	-328.95
159	SEG32	-1139.32	-328.95
160	SEG33	-1105.32	-328.95
161	SEG34	-1071.32	-328.95
162	SEG35	-1037.32	-328.95
163	SEG36	-1003.32	-328.95
164	SEG37	-969.32	-328.95
165	SEG38	-935.32	-328.95
166	SEG39	-901.32	-328.95
167	SEG40	-867.32	-328.95
168	SEG41	-833.32	-328.95
169	SEG42	-799.32	-328.95
170	SEG43	-765.32	-328.95
171	SEG44	-731.32	-328.95
172	SEG45	-697.32	-328.95
173	SEG46	-663.32	-328.95
174	SEG47	-629.32	-328.95
175	SEG48	-595.32	-328.95
176	SEG49	-561.32	-328.95
177	SEG50	-527.32	-328.95
178	SEG51	-493.32	-328.95
179	SEG52	-459.32	-328.95
180	SEG53	-425.32	-328.95
181	SEG54	-391.32	-328.95
182	SEG55	-357.32	-328.95
183	SEG56	-323.32	-328.95
184	SEG57	-289.32	-328.95
185	SEG58	-255.32	-328.95
186	SEG59	-221.32	-328.95
187	SEG60	-187.32	-328.95
188	SEG61	-153.32	-328.95
189	SEG62	-119.32	-328.95
190	SEG63	-85.32	-328.95
191	SEG64	-51.32	-328.95
192	SEG65	-17.32	-328.95
193	SEG66	16.68	-328.95
194	SEG67	50.68	-328.95
195	SEG68	84.68	-328.95
196	SEG69	118.68	-328.95

PAD No.	PAD Name	X	Y
197	SEG70	152.68	-328.95
198	SEG71	186.68	-328.95
199	SEG72	220.68	-328.95
200	SEG73	254.68	-328.95
201	SEG74	288.68	-328.95
202	SEG75	322.68	-328.95
203	SEG76	356.68	-328.95
204	SEG77	390.68	-328.95
205	SEG78	424.68	-328.95
206	SEG79	458.68	-328.95
207	SEG80	492.68	-328.95
208	SEG81	526.68	-328.95
209	SEG82	560.68	-328.95
210	SEG83	594.68	-328.95
211	SEG84	628.68	-328.95
212	SEG85	662.68	-328.95
213	SEG86	696.68	-328.95
214	SEG87	730.68	-328.95
215	SEG88	764.68	-328.95
216	SEG89	798.68	-328.95
217	SEG90	832.68	-328.95
218	SEG91	866.68	-328.95
219	SEG92	900.68	-328.95
220	SEG93	934.68	-328.95
221	SEG94	968.68	-328.95
222	SEG95	1002.68	-328.95
223	SEG96	1036.68	-328.95
224	SEG97	1070.68	-328.95
225	SEG98	1104.68	-328.95
226	SEG99	1138.68	-328.95
227	SEG100	1172.68	-328.95
228	SEG101	1206.68	-328.95
229	SEG102	1240.68	-328.95
230	SEG103	1274.68	-328.95
231	SEG104	1308.68	-328.95
232	SEG105	1342.68	-328.95
233	SEG106	1376.68	-328.95
234	SEG107	1410.68	-328.95
235	SEG108	1444.68	-328.95
236	SEG109	1478.68	-328.95
237	SEG110	1512.68	-328.95
238	SEG111	1546.68	-328.95
239	SEG112	1580.68	-328.95
240	SEG113	1614.68	-328.95
241	SEG114	1648.68	-328.95
242	SEG115	1682.68	-328.95
243	SEG116	1716.68	-328.95
244	SEG117	1750.68	-328.95
245	SEG118	1784.68	-328.95
246	SEG119	1818.68	-328.95

PAD No.	PAD Name	X	Y
247	SEG120	1852.68	-328.95
248	SEG121	1886.68	-328.95
249	SEG122	1920.68	-328.95
250	SEG123	1954.68	-328.95
251	SEG124	1988.68	-328.95
252	SEG125	2022.68	-328.95
253	SEG126	2056.68	-328.95
254	SEG127	2090.68	-328.95
255	SEG128	2124.68	-328.95
256	SEG129	2158.68	-328.95
257	SEG130	2192.68	-328.95
258	SEG131	2226.68	-328.95
259	COM32	2260.68	-328.95
260	COM33	2294.68	-328.95
261	COM34	2328.68	-328.95
262	COM35	2362.68	-328.95
263	COM36	2396.68	-328.95
264	COM37	2430.68	-328.95
265	COM38	2464.68	-328.95
266	COM39	2498.68	-328.95
267	COM40	2532.68	-328.95
268	COM41	2566.68	-328.95
269	COM42	2600.68	-328.95
270	COM43	2845.81	-357
271	COM44	2845.81	-323
272	COM45	2845.81	-289
273	COM46	2845.81	-255
274	COM47	2845.81	-221
275	COM48	2845.81	-187
276	COM49	2845.81	-153
277	COM50	2845.81	-119
278	COM51	2845.81	-85
279	COM52	2845.81	-51
280	COM53	2845.81	-17
281	COM54	2845.81	17
282	COM55	2845.81	51
283	COM56	2845.81	85
284	COM57	2845.81	119
285	COM58	2845.81	153
286	COM59	2845.81	187
287	COM60	2845.81	221
288	COM61	2845.81	255
289	COM62	2845.81	289
290	COM63	2845.81	323
291	COMS2	2845.81	357

11.5. COG Align Key Coordinate

-- Alignment Mark coordinate

Left (-2594.27, 148.43)

Right (2586.56, 148.43)

-- Alignment Mark size

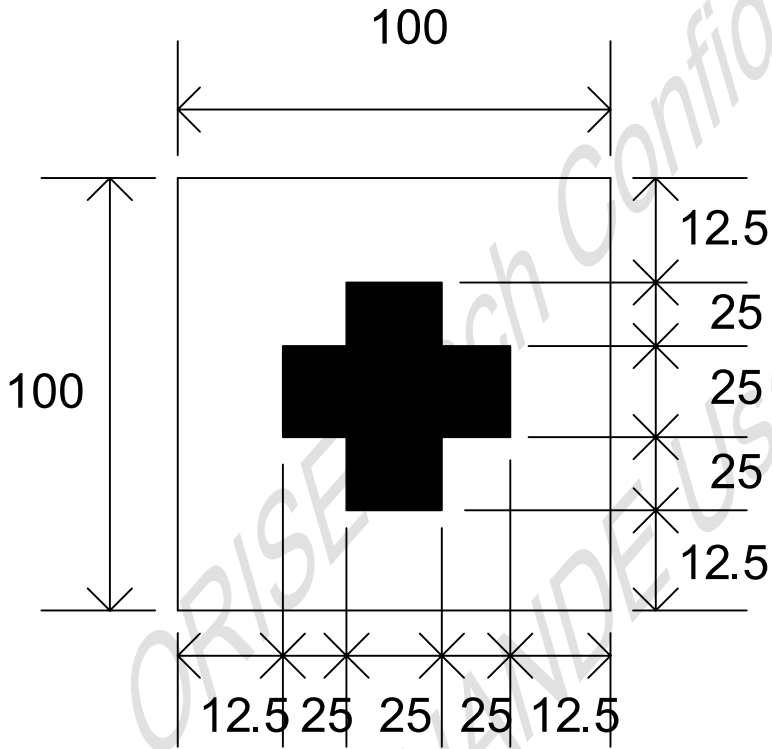

12. DISCLAIMER

The information appearing in this publication is believed to be accurate.

Integrated circuits sold by ORISE Technology are covered by the warranty and patent indemnification provisions stipulated in the terms of sale only. ORISE Technology makes no warranty, express, statutory implied or by description regarding the information in this publication or regarding the freedom of the described chip(s) from patent infringement. FURTHERMORE, ORISE Technology MAKES NO WARRANTY OF MERCHANTABILITY OR FITNESS FOR ANY PURPOSE. ORISE Technology reserves the right to halt production or alter the specifications and prices at any time without notice. Accordingly, the reader is cautioned to verify that the data sheets and other information in this publication are current before placing orders. Products described herein are intended for use in normal commercial applications. Applications involving unusual environmental or reliability requirements, e.g. military equipment or medical life support equipment, are specifically not recommended without additional processing by ORISE Technology for such applications. Please note that application circuits illustrated in this document are for reference purposes only.

ORISE Tech Confidential
For QUANDE Use Only

13. REVISION HISTORY

Date	Revision #	Description	Page
MAR. 30, 2007	1.0	Release Version	
JAN. 12, 2007	0.7	Modify temperature range Modify note *11	39 - 48 41
DEC. 05, 2006	0.6	1. Move Ordering Information to Chapter 3 2. Modify 6.11.2. The voltage regulator circuit 3. Modify Reference Circuit Examples(Note) 4. Modify Figure 12、13 5. Modify 7.21 Set Driving Mode (Double Byte Command) 6. Add PAD Dimension 7. Add Bump Characteristic	4 19 21 21、22 32 53 53
JUL. 26, 2006	0.5	1. Update 4.5 Test Terminals 2. Modify Figure 13 3. Modify *10.	9 22 41
JUL. 24, 2006	0.4	1. Modify 10.1. PAD Assignment and Locations 2. Modify 10.3. PAD Locations (No. 83~93) 3. Remove *3 IRS & *5 IRS	53 55,56 41
JUL. 18, 2006	0.3	Modify PAD No. (5, 7, 10, 79)	55
JUL. 11, 2006	0.2	1. Modify block diagram 2. Modify SIGNAL DESCRIPTIONS(PIN NO.) 3. Remove 5.11.2.2 & 5.11.2.3 4. Modify 5.14.1.1 (Figure 12) & 5.14.1.2 (Figure 13) 5. Modify 6.19.2 Table : Change (one second / 0.5 second) 6. Insert 6.21 Set Driving Mode (Double Byte Command) 7. Add 6.25 Oscillator Frequency selection 8. Modify 6.26 Table : Add 21). & 25) 9. Update 10.1 Chip Size	5 6 19 21,22 31 33 34 36 53
APR. 07, 2006	0.1	Original	56