



EK9713CA

Rev. 1.1

DATA SHEET

1200-Output TFT LCD
Source Driver with TCON

fitipower integrated technology Inc.

Table of Contents

	Page
1. GENERAL DESCRIPTION.....	2
2. FEATURES.....	2
3. BLOCK DIAGRAM	3
4. PIN DESCRIPTION.....	6
4.1. Value of wiring resistance to each pin.....	8
5. FUNCTION DESCRIPTION.....	9
5.1. Power On/Off Sequence	9
5.2. Input Data VS Output Channels	10
5.3. Input Data VS Output Voltage.....	11
5.4. Input Data and Output Voltage Reference Table.....	12
5.5. Data Input Format.....	13
5.6. Timing Characteristic	14
6. ELECTRICAL SPECIFICATION.....	15
6.1. Absolute Maximum Ratings	15
6.2. Recommended Operating Range.....	15
6.3. DC Characteristics.....	16
6.4. AC Characteristics.....	17
6.5. Timing Table.....	17
6.6. Timing Waveform.....	18
7. PAD DIAGRAM.....	20
7.1. CHIP OUTLINE DIMENSIONS	23
7.2. ALIGNMENT MARK DIMENSION (unit: um).....	25
7.3. PAD COORDINATES	26
8. DEFINITIONS	60
8.1. Data Sheet Status	60
8.2. Life Support Application	60
9. REVISION HISTORY	60

1200-Output TFT LCD Source Driver with TCON**1. GENERAL DESCRIPTION**

EK9713CA is a highly integrated 1200 channel source driver with TTL interface Timing Controller for color TFT-LCD panels. EK9713CA is special designed for dual-gate architecture TFT panel. This chip is dedicated for the display resolution of: 800*480 and 800*600 application.

EK9713CA input timing support TTL digital 24bit parallel RGB data format, and source output support 8-bit resolution 256 gray scales with dithering feature enabled. Operating parameters can be set via pin control for all control features. Special circuit architecture is designed for lower power dissipation.

EK9713CA can be configured as dual-gate operation mode for reducing FPC amount and save the cost. With wide range of supply voltages and many pin control features make this chip more suitable for various applications.

2. FEATURES

Special design for small-sized color TFT LCD source drivers with timing controller

Integrated 1200 channel source driver

Support dual-gate operation mode

Support display resolutions : 800(RGB)x480 ~ 800(RGB)x600

Support TTL 24-bit parallel (RGB) input timing

Source output with 8-bit resolution 256 gray scale (2-bit dithering)

Support Delta or Stripe color filter configuration

Support stand-by mode for low power consumption

Pin controlled UP/DOWN, LEFT/RIGHT, HV/DE mode select function

Embedded Gamma Table for special custom request

Support external V1 ~ V14 pad for Gamma adjusting

Output dynamic range: 0.1 ~ AVDD-0.1V

Power for source driver voltage AVDD: 6.5V ~ 13.5V

Power for digital interface circuit VDD: 1.8 ~ 3.6V

Max. operating frequency: 50 MHz

COG package

3. BLOCK DIAGRAM

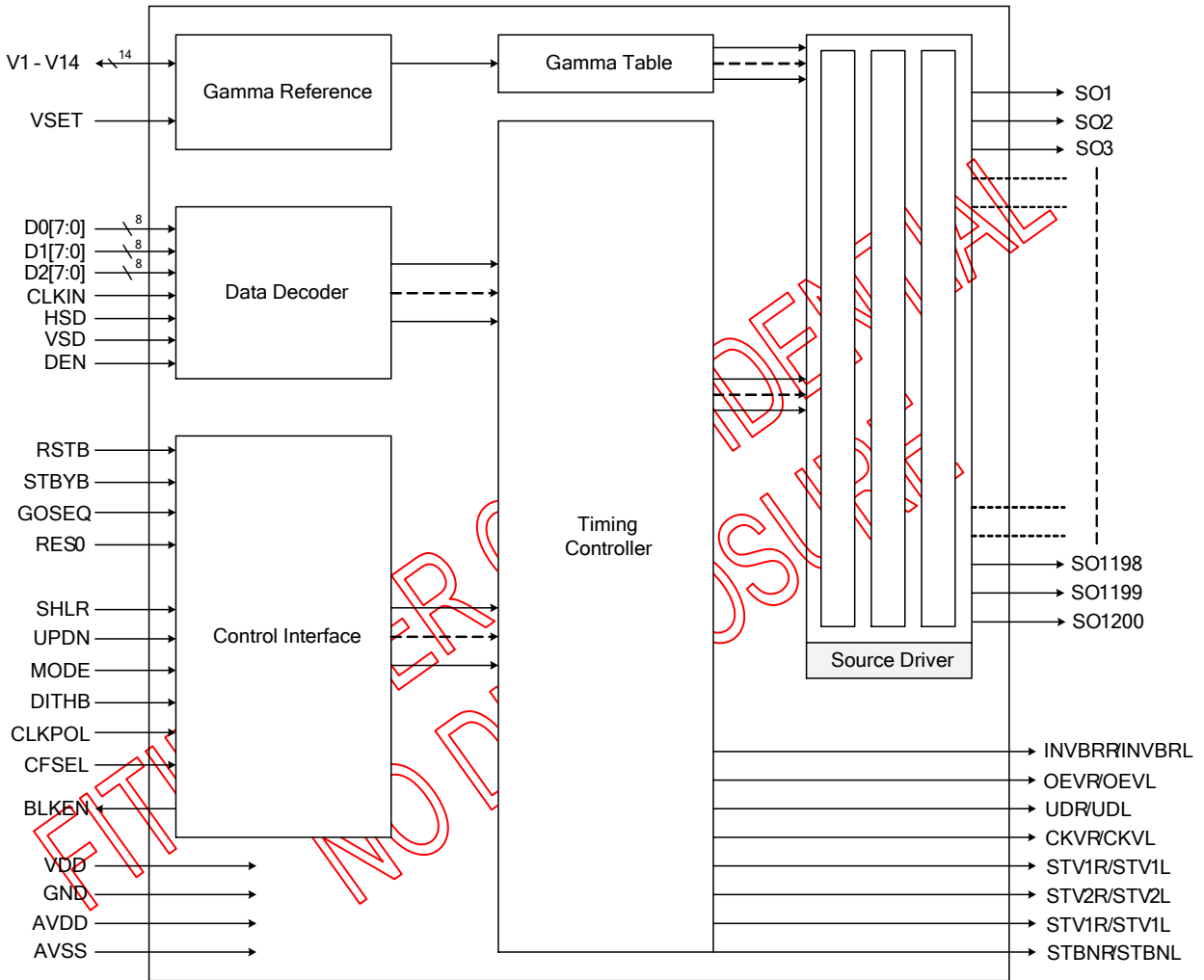

Block Diagram

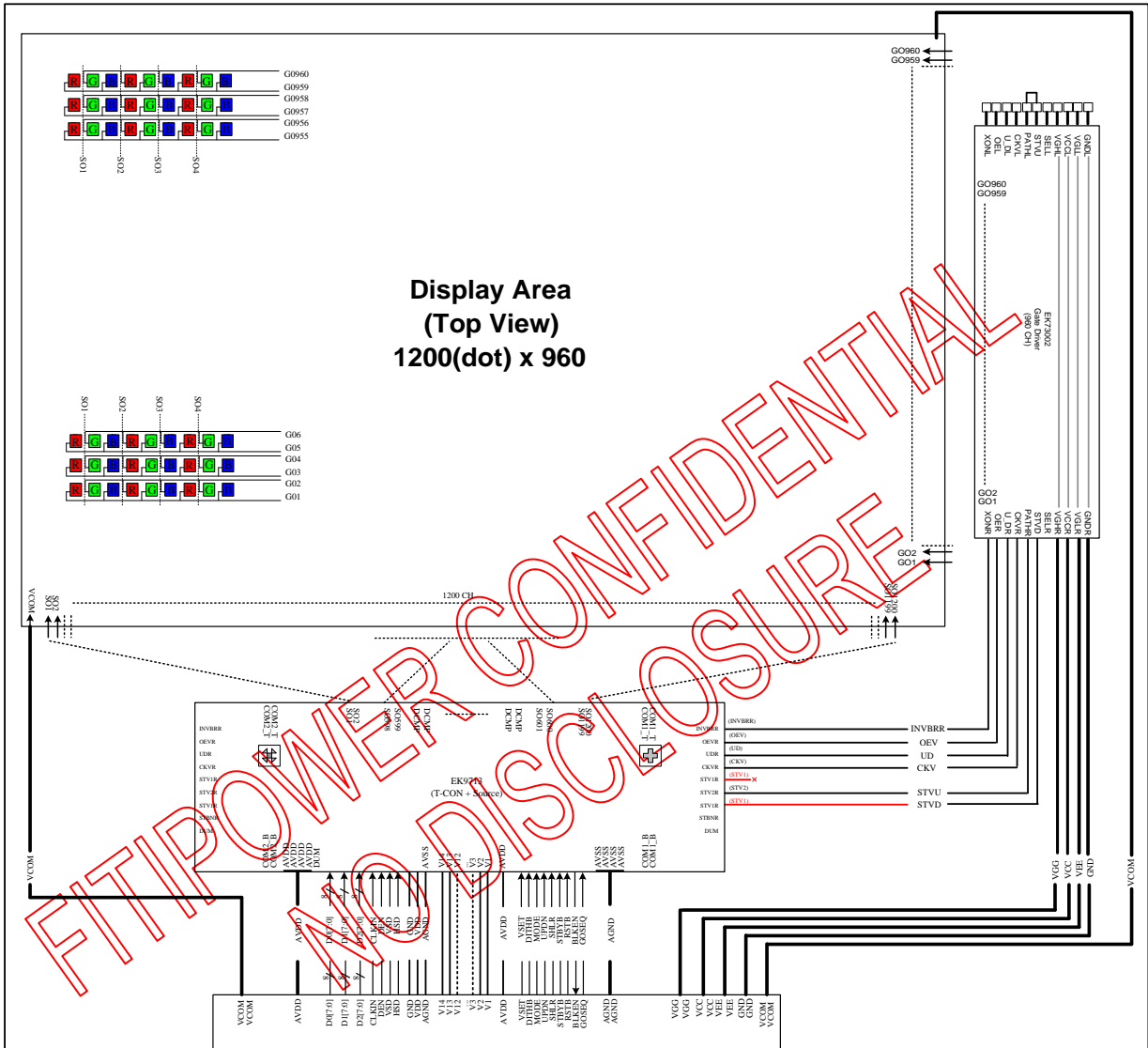

Application Block Diagram – Dual Gate Application

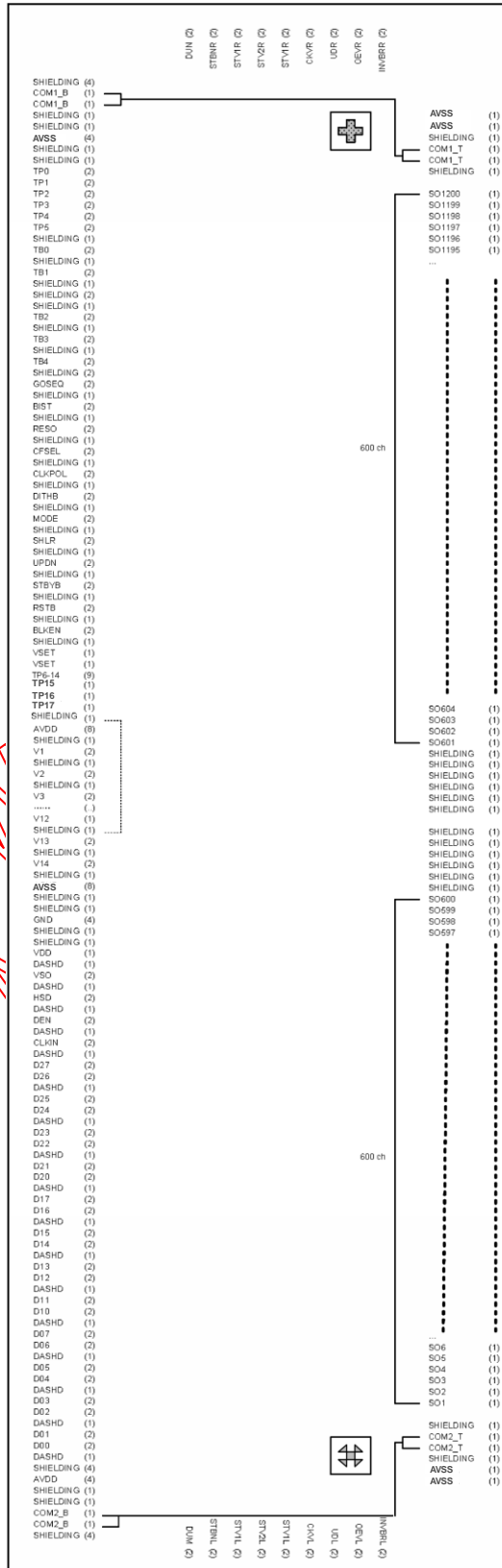

Pad Sequence (Bump Side)

4. PIN DESCRIPTION

Pin Description

Pin Name	Pin Type	Description
D07~D00 D17~D10 D27~D20	Input	Parallel data Input. For TTL 24-bit parallel RGB image data input. D[07:00] = R[7:0] data; D[17:10] = G[7:0] data; D[27:20] = B[7:0] data. For 18bit RGB interface, connect two LSB bits of all the R/G/B data buses to GND.
CLKIN	Input	Clock for Input Data. Data latched at rising/falling edge of this signal. Default falling edge.
HSD	Input	Horizontal Sync input. Negative polarity. Normally pull high.
VSD	Input	Vertical Sync input. Negative polarity. Normally pull high.
DEN	Input	Data Input Enable. Active High to enable the data input bus under "DE Mode". Normally pull low.
MODE	Input	DE / SYNC mode select. Normally pull high H: DE mode. L: HSD/VSD mode.
RES0	Input	Display resolution selection. RES0 = "0", for 800(RGB)*480 display resolution RES0 = "1" for 800(RGB)*600 display resolution
DITHB	Input	Dithering function enable control. Normally pull high DITHB = "1" Disable internal dithering function DITHB = "0", Enable internal dithering function
CLKPOL	Input	Input clock edge selection. Normally pull low CLKPOL = "1" Latch data at CLKIN rising edge. CLKPOL = "0" Latch data at CLKIN falling edge. (Default)
BLKEN	Output	Backlight enable control signal for external controller. BLKEN = "1" Logical control signal to turn on external backlight controller BLKEN = "0", Turn off external backlight controller Note: Refer to the Power On/Off Sequence for the detail information.
CFSEL	Input	Color Filter type selection. Normally pull high CFSEL = "1", Stripe mode. (Default) CFSEL = "0", Delta mode
V1 ~ V14	Bi-direction	When VSET="0", INTERNAL Gamma Table is used. V1~V14 pad are un-used. When VSET="1". V1~V14 are the external gamma correction points. The voltage of these pins must be: AVSS<V14<V13<V12<V11<V10<V9<V8;V7<V6<V5<V4<V3<V2<V1<AVDD
VSET	Input	Gamma correction source select. Normally pull low. VSET = "0", use internal Gamma Reference voltage (AVDD). (Default mode) VSET = "1", use external Gamma Correction Input (V1~V14).
RSTB	Input	Global reset pin. Active Low to enter Reset State. Suggest to connecting with an RC reset circuit for stability. Normally pull high.
STBYB	Input	Standby mode, Normally pull high. STBYB = "1", normal operation STBYB = "0", timing controller, source driver will turn off, all output are High-Z

Pin Name	Pin Type	Description
SHLR	Input	Source Right or Left sequence control. Normally pull high. SHLR = "L", shift left: last data = S1←S2←S3.....←S1200 = first data. SHLR = "H", shift right: first data = S1→S→S3.....→S1200 = last data.
UPDN	Input	Gate Up or Down scan control. Normally pull low. UPDN = "L", STV2 output vertical start pulse and UD pin output logical "0" to Gate driver. UPDN = "H", STV1 output vertical start pulse and UD pin output logical "1" to Gate driver.
BIST	Input	Normal Operation/BIST pattern select. Normally pull low BIST = H : BIST(DCLK input is not needed) BIST = L : Normal Operation
GOSEQ	Input	Gate on sequence. Normally pull low. Please refer to Note 1. GOSEQ = H : INVBRR/INVBRL = L Gate on G1→G2→G4→G3→G5→G6→G8→G7..... (UPDN = "H") GOSEQ = L : INVBRR/INVBRL = H Gate on G1→G2→G3→G4→G5→G6→G7→G8..... (UPDN = "H")
OEVR/OEVL	Output	Gate driver control signal.
UDR/UDL	Output	Gate driver control signal.
CKVR/CKVL	Output	Gate driver control signal.
STV1R/STV1L	Output	Gate driver control signal.
STV2R/STV2L	Output	Gate driver control signal.
STBNR/STBNL	Output	Gate driver control signal.
INVBRR/INVBRL	Output	Gate driver control signal (For special Gate on sequence).
AVDD	Power Input	Power supply for analog circuits
AVSS	Power Input	Ground pins for analog circuits
VDD/VDDD	Power Input	Power supply for digital circuits
GND/VSSD	Power Input	Ground pins for digital circuits
SO1~SO1200	Output	Source Driver Output Signals. All outputs will be of unknown values under stand-by mode.
ALIGN	Mark	For assembly alignment.
COM1_B COM1_B	Shorted line	Internal link together between input side and output side.
COM1_T COM2_T	Shorted line	Internal link together between input side and output side.
TP17~0 TB0~4	Testing	Float these pins for normal operation.
SHIELDING	Shielding	IC Shielding pads. Those pins are internally connected to the AVSS. DO NOT connect to any WOA on the panel.
DASHD	Shielding	Data Bus Shielding pad. Those pins are internally connected to the GND. RECOMMAND to add shielding lines on the FPC to reduce EMI.
DUM	Dummy	Dummy pads. Those pins are floating pads.

Note 1.

GOSEQ = L, INVBRRINVBRL= H,
UPDN = H

With traditional Gate driver.

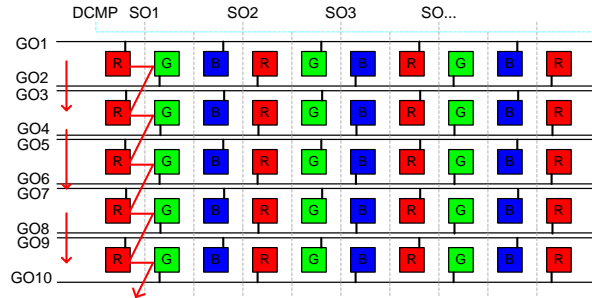

GOSEQ = H, INVBRRINVBRL= L,
UPDN = H

With special design Gate driver

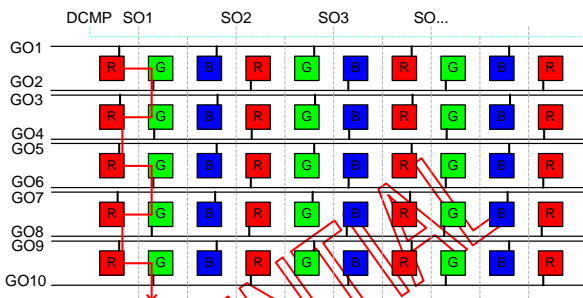

EK9713CA Pass Line Description:

Pass Line No:	Pad Name	
1	COM1_B	COM1_T
2	COM2_B	COM2_T

4.1. Value of wiring resistance to each pin

The recommended wiring resistance values are shown below. The wiring resistance values affect the current capacity of the power supply, so be sure to design using values that do not exceed those recommended.

Pin Name	Wiring Resistance value(Ω)	Pin Name	Wiring resistance value (Ω)
AVDD	<5	SHLR	<500
AVSS	<5	UPDN	<500
VDD	<10	BIST	<500
GND	<10	MODE	<500
V1~V14	<10	RES0	<500
D00~D07	<50	CLKPOL	<500
D10~D17	<50	BLKEN	<500
D20~D27	<50	CFSEL	<500
CLKIN	<50	VSET	<500
VSD	<50	OEVx	<500
HSD	<50	UDx	<500
DEN	<50	CKVx	<500
RSTB	<500	STV1x	<500
STBYB	<500	STV2x	<500
DITHB	<500	STBNx	<500

5. FUNCTION DESCRIPTION

5.1. Power On/Off Sequence

In order to prevent IC from power on reset fail, the rising time (TPOR) of the digital power supply VDD should be maintained within the given specifications. Refer to “AC Characteristics” for more detail on timing.

This is another paragraph of sub-function description.

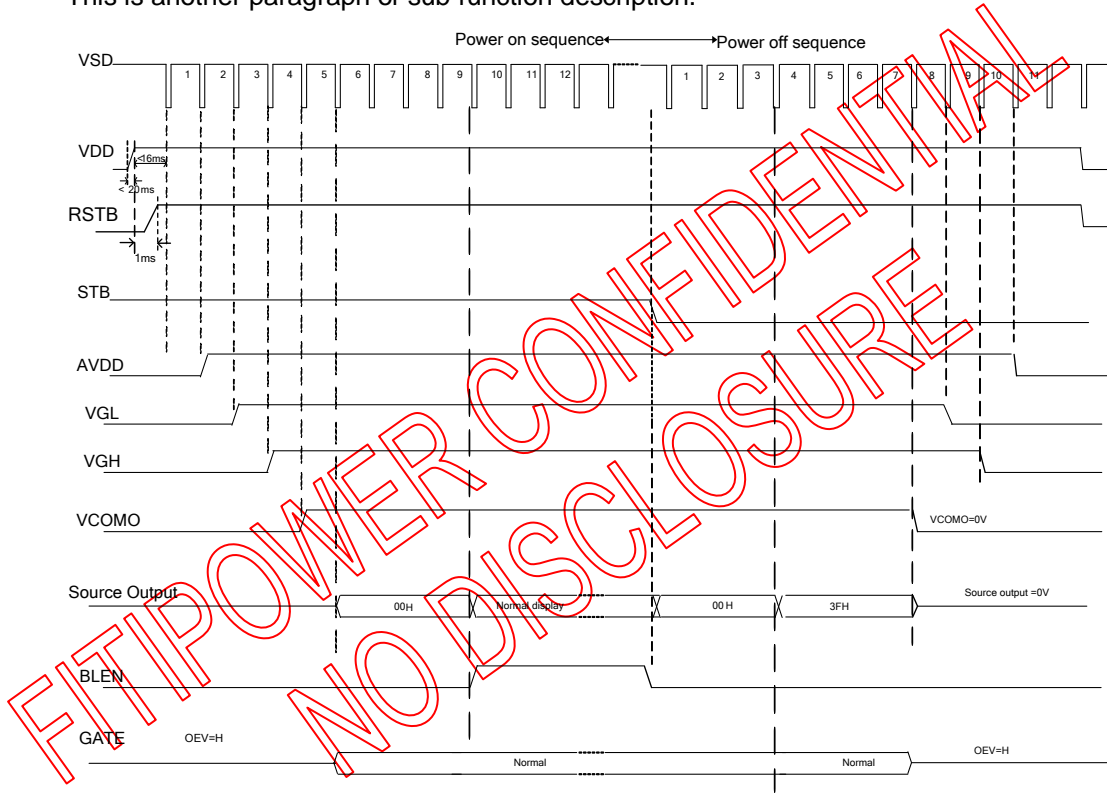

Power-On/Off Timing Sequence

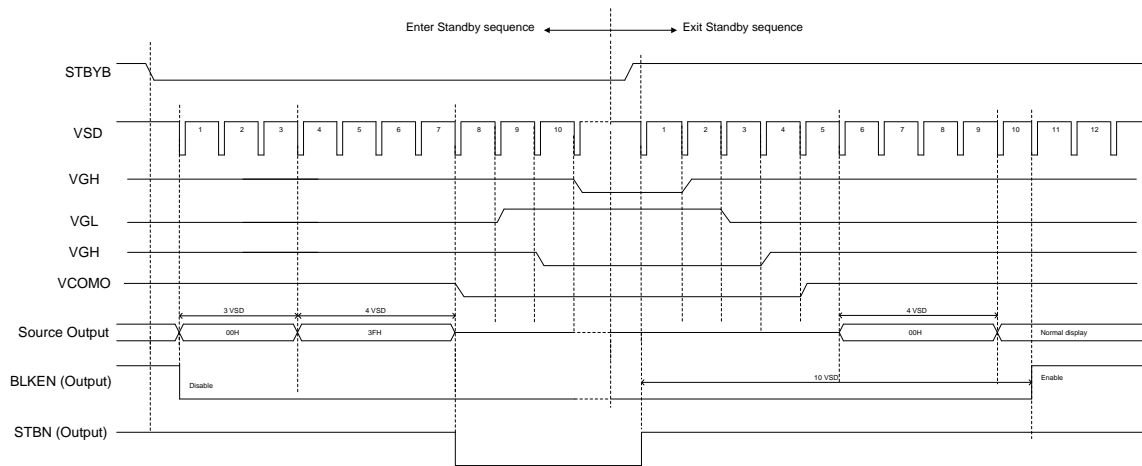

Enter and Exit Standby Mode Sequence

5.2. Input Data VS Output Channels

5.2.1. CFSEL="1", Stripe Mode, UDPN=1

SHLR="1", right shift

Output	SO1	SO2	SO3	---	SO1198	SO1199	SO1200
Order	First data			→	Last data		
Odd Line/Gn	D07~D00	D27~D20	D17~D10	---	D07~D00	D27~D20	D17~D10
Odd Line/Gn+1	D17~D10	D07~D00	D27~D20	---	D17~D10	D07~D00	D27~D20
Even Line/Gn	D07~D00	D27~D20	D17~D10	---	D07~D00	D27~D20	D17~D10
Even Line/Gn+1	D17~D10	D07~D00	D27~D20	---	D17~D10	D07~D00	D27~D20

SHLR="0", left shift

Output	SO1	SO2	SO3	---	SO1198	SO1199	SO1200
Order	Last data			←	First data		
Odd Line/Gn	D07~D00	D27~D20	D17~D10	---	D07~D00	D27~D20	D17~D10
Odd Line/Gn+1	D17~D10	D07~D00	D27~D20	---	D17~D10	D07~D00	D27~D20
Even Line/Gn	D07~D00	D27~D20	D17~D10	---	D07~D00	D27~D20	D17~D10
Even Line/Gn+1	D17~D10	D07~D00	D27~D20	---	D17~D10	D07~D00	D27~D20

5.2.2. CFSEL="0", Delta Mode, UDPN=1

SHLR="1", right shift

Output	SO1	SO2	SO3	---	SO1198	SO1199	SO1200
Order	First data			→	Last data		
Odd Line/Gn	D07~D00	D27~D20	D17~D10	---	D07~D00	D27~D20	D17~D10
Odd Line/Gn+1	D17~D10	D07~D00	D27~D20	---	D17~D10	D07~D00	D27~D20
Even Line/Gn	D17~D10	D07~D00	D27~D20	---	D17~D10	D07~D00	D27~D20
Even Line/Gn+1	D27~D20	D17~D10	D07~D00	---	D27~D20	D17~D10	D07~D00

SHLR="0", left shift

Output	SO1	SO2	SO3	---	SO1198	SO1199	SO1200
Order	Last data			←	First data		
Odd Line/Gn	D07~D00	D27~D20	D17~D10	---	D07~D00	D27~D20	D17~D10
Odd Line/Gn+1	D17~D10	D07~D00	D27~D20	---	D17~D10	D07~D00	D27~D20
Even Line/Gn	D17~D10	D07~D00	D27~D20	---	D17~D10	D07~D00	D27~D20
Even Line/Gn+1	D27~D20	D17~D10	D07~D00	---	D27~D20	D17~D10	D07~D00

5.3. Input Data VS Output Voltage

The figure below shows the relationship between the input data and the output voltage. Refer to the following pages for the relative resistor values and voltage calculation method.

Gamma Tables vary for each customer.

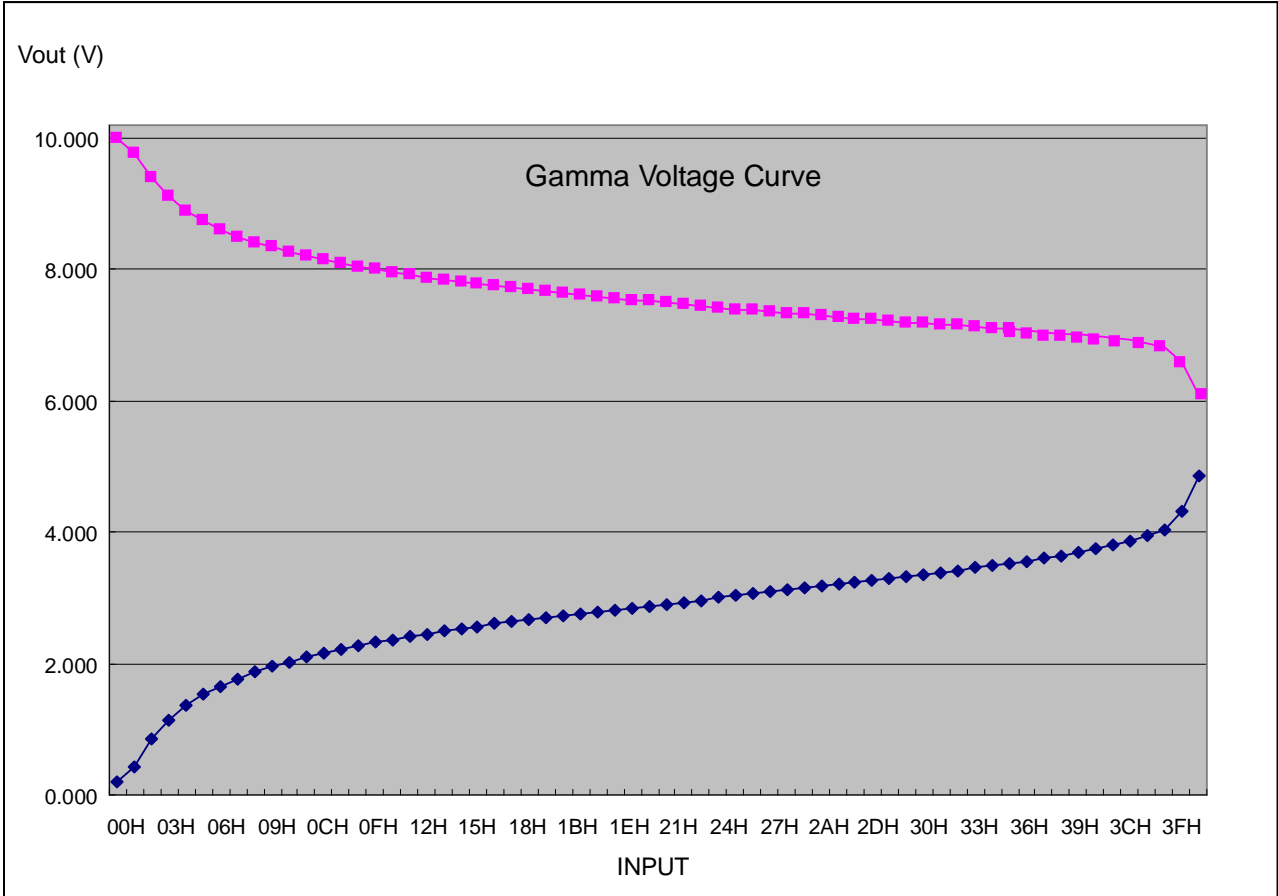

Remark: AVDD-0.1 > V1 > V2 > V3 > V4 > V5 > V6 > V7; V8 > V9 > V10 > V11 > V12 > V13 > V14 > AVSS+0.1V

5.4. Input Data and Output Voltage Reference Table

Input Data and Output Voltage Reference Table

Asy-Gamma @AVDD=10.4V					
Level	V+	V-	Level	V+	V-
0	9.99544	0.19544	32	7.62801	2.96276
1	9.74167	0.46609	33	7.6064	2.99432
2	9.38791	0.84598	34	7.58521	3.02776
3	9.14826	1.10631	35	7.56694	3.05722
4	8.959	1.31459	36	7.54802	3.0877
5	8.81096	1.47967	37	7.52618	3.11692
6	8.69215	1.61326	38	7.50274	3.14577
7	8.59155	1.7279	39	7.48152	3.17187
8	8.50539	1.82725	40	7.46153	3.20067
9	8.42879	1.91694	41	7.44259	3.23201
10	8.3584	1.99876	42	7.43079	3.27186
11	8.30101	2.06792	43	7.41956	3.30901
12	8.24502	2.13436	44	7.40122	3.34041
13	8.19379	2.19625	45	7.38502	3.37533
14	8.14825	2.252	46	7.36578	3.4085
15	8.10377	2.30712	47	7.34928	3.44419
16	8.0645	2.35712	48	7.32513	3.4736
17	8.02666	2.40518	49	7.30037	3.50375
18	7.98939	2.45231	50	7.28065	3.54065
19	7.95731	2.49381	51	7.26167	3.58033
20	7.92413	2.53902	52	7.24646	3.62519
21	7.89613	2.58001	53	7.22793	3.66813
22	7.86902	2.61944	54	7.21236	3.72165
23	7.8407	2.66138	55	7.19252	3.77243
24	7.81479	2.69689	56	7.17277	3.82699
25	7.78911	2.73111	57	7.15248	3.89333
26	7.76239	2.76723	58	7.1318	3.96111
27	7.73804	2.80206	59	7.10615	4.04641
28	7.716	2.83394	60	7.07255	4.13526
29	7.69307	2.8673	61	7.01529	4.24283
30	7.6691	2.90199	62	6.9063	4.39937
31	7.64845	2.93198	63	6.28445	5.08445

Note: Gamma Tables Vary for each customer.

5.5. Data Input Format

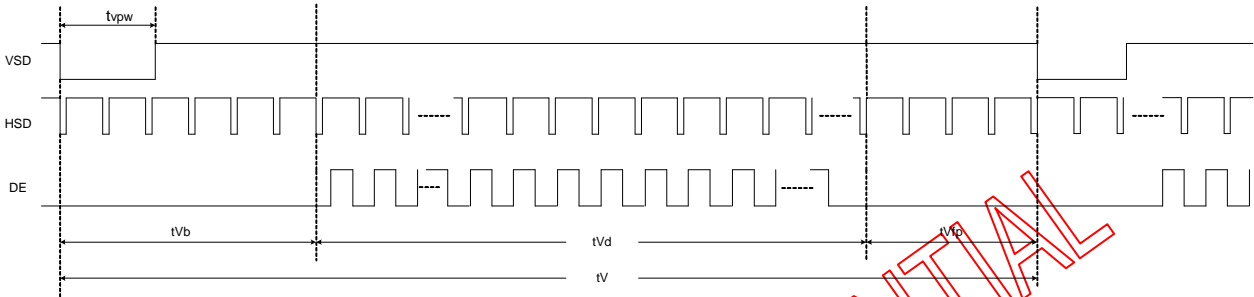

Vertical input timing

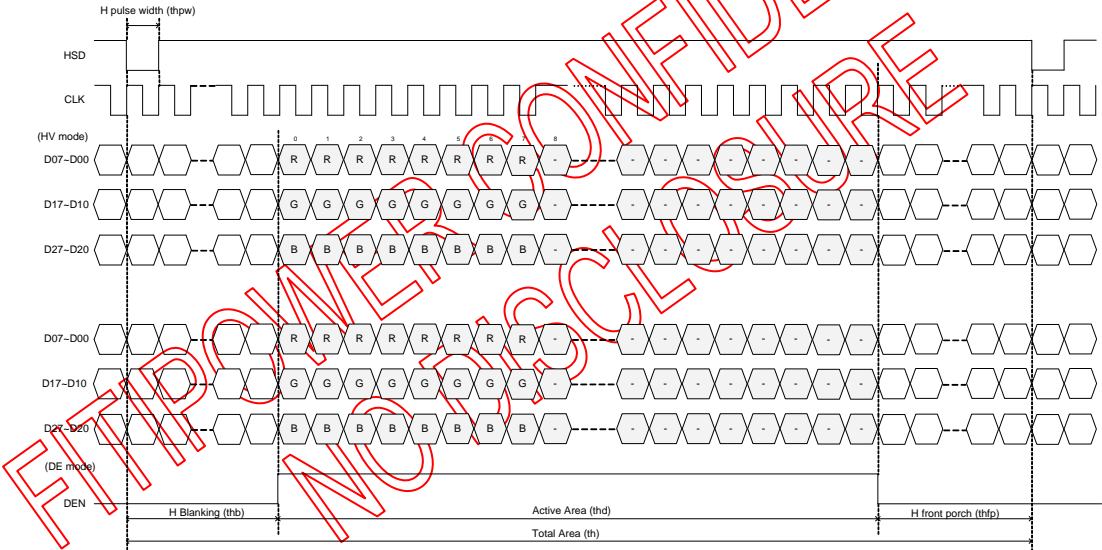

Horizontal input timing

5.6. Timing Characteristic

5.6.1. For 800 × 480 panel

Horizontal input timing

Parameter	Symbol	Value			Unit
Horizontal display area	thd	800			DCLK
DCLK frequency	fclk	Min.	Typ.	Max	MHz
		-	33.3	50	
1 Horizontal Line	th	862	1056	1200	DCLK
HSD pulse width	thpw	Min.	1		
		Typ.	-		
		Max.	40		
HSD Back Porch (Blanking)	thb	46	46	46	
HSD Front Porch	thfp	16	210	354	

Vertical input timing

Parameter	Symbol	Min.	Typ.	Max.	Unit
Vertical display area	tvd	480			H
VSD period time	tv	510	525	650	H
VSD pulse width	tvpw	1	-	20	H
VSD Back Porch (Blanking)	tvb	23	23	23	H
VSD Front Porch	tvfp	7	22	147	H

5.6.2. For 800 × 600 panel

Horizontal input timing

Parameter	Symbol	Value			Unit
Horizontal display area	thd	800			DCLK
DCLK frequency	fclk	Min.	Typ.	Max	MHz
		-	40	50	
1 Horizontal Line	th	862	1056	1200	DCLK
HSD pulse width	thpw	Min.	1		
		Typ.	-		
		Max.	40		
HSD Back Porch (Blanking)	thb	46	46	46	
HSD Front Porch	thfp	16	210	354	

Vertical input timing

Parameter	Symbol	Min.	Typ.	Max.	Unit
Vertical display area	tvd	600			H
VSD period time	tv	624	635	700	H
VSD pulse width	tvpw	1	-	20	H
VSD Back Porch (Blanking)	tvb	23	23	23	H
VSD Front Porch	tvfp	1	12	77	H

6. ELECTRICAL SPECIFICATION

6.1. Absolute Maximum Ratings

VOLTAGE (TA = 25°C, GND = AVSS = 0V)

	Min.	Max.	Unit
Digital Supply Voltage, VDD	-0.5	+5.0	V
Analog Supply Voltage, AVDD, V1~V14	-0.5	+15.0	V

TEMPERATURE

	Min.	Max.	Unit
Operating temperature	-20	+85	°C
Storage temperature	-55	+125	°C

Comments

Stresses above those listed under "Absolute Maximum Ratings" may cause permanent damage to the device. These are stress ratings only. Functional operation of this device at these or any other conditions above those indicated in the operational sections of this specification is not implied and exposed to absolute maximum rating conditions for extended periods may affect device reliability.

6.2. Recommended Operating Range

Recommended Operating Range (TA = -20 to 85°C, GND = AVSS = 0V)

Parameter	Symbol	Min.	Typ.	Max.	Unit
Digital supply voltage	VDD	1.8	3.3	3.6	V
Analog supply voltage	AVDD	6.5	-	13.5	V
Digital input voltage	VIN	0	-	VDD	V

6.3. DC Characteristics

DC Characteristics

(TA = -20 to 85°C, VDD = 1.8 to 3.6V, AVDD = 6.5 to 13.5V, GND = AVSS = 0V)

Parameter	Symbol	Condition	Min.	Typ.	Max.	Unit
Low level input voltage	Vil	For the digital circuit	0	-	0.3×VDD	V
High level input voltage	Vih	For the digital circuit	0.7×VDD	-	VDD	V
Input leakage current	Ii	For the digital circuit	-	-	±1	μA
High level output voltage	Voh	Ioh= -400 μA	VDD-0.4	-	-	V
Low level output voltage	Vol	Iol= +400 μA	-	-	GND+0.4	V
Pull low/high resistor	Ri	For the digital input pin @ VDD=3.3V	150K	250K	350K	ohm
Digital Operation current	Idd	Fclk=40 MHz, FLD=37.88KHz, VDD=3.3V	-	8	10	mA
Digital Stand-by current	Ist1	Clock and all functions are stopped	-	10	50	μA
Analog Operating Current	Idda	No load, Fclk=40MHz, FLD=37.88KHz @ AVDD=10V, V1=8V, V14=0.4V	-	10	12	mA
Analog Stand-by current	Ist2	No load, Clock and all functions are stopped	-	10	50	μA
Input level of V1 ~ V7	Vref1	Gamma correction voltage input	0.4*AVDD	-	AVDD-0.1	V
Input level of V8 ~ V14	Vref2	Gamma correction voltage input	0.1	-	0.6*AVDD	V
Output Voltage deviation	Vod1	Vo = AVSS+0.1V ~ AVSS+0.5V and Vo = AVDD-0.5V ~ AVDD-0.1V	-	±20	±35	mV
Output Voltage deviation	Vod2	Vo = AVSS+0.5V ~ AVDD-0.5V	-	±15	±20	mV
Output Voltage Offset between Chips	Voc	Vo = AVSS+0.5V ~ AVDD-0.5V	-	-	±20	mV
Dynamic Range of Output	Vdr	SO1 ~ SO1200	0.1	-	AVDD-0.1	V
Sinking Current of Outputs	IOLy	SO1 ~ SO1200; Vo=0.1V v.s 1.0V, AVDD=13.5V	80	-	-	uA
Driving Current of Outputs	IOHy	SO1 ~ SO1200; Vo=13.4V v.s 12.5V, AVDD=13.5V	80	-	-	uA
Resistance of Gamma Table	Rg	Rn: Internal gamma resistor	0.7*Rn	1.0*Rn	1.3*Rn	ohm

6.4. AC Characteristics

AC Characteristics

(TA = -20 to 85°C, VDD = 1.8 to 3.6V, AVDD = 6.5 to 13.5V, GND = AVSS = 0V)

Parameter	Symbol	Condition	Min.	Typ.	Max.	Unit
VDD Power On Slew rate	TPOR	From 0V to 90% VDD	-	-	20	ms
RSTB pulse width	TRST	CLKIN = 40MHz	1	-	-	ms
CLKIN cycle time	Tcph	-	20	-	-	ns
CLKIN pulse duty	Tcwh	-	40	50	60	%
VSD setup time	Tvst	-	8	-	-	ns
VSD hold time	Tvhd	-	8	-	-	ns
HSD setup time	Thst	-	8	-	-	ns
HSD hold time	Thhd	-	8	-	-	ns
Data set-up time	Tdsu	D0[7:0], D1[7:0], D2[7:0] to CLKIN	8	-	-	ns
Data hold time	Tdhd	D0[7:0], D1[7:0], D2[7:0] to CLKIN	8	-	-	ns
DEN setup time	Tesu	-	8	-	-	ns
DEN hold time	Tehd	-	8	-	-	ns
Output stable time	Tsst	10% to 90% target voltage. CL=120pF, R=10K ohm	-	-	6	us

6.5. Timing Table

Parallel 24-bit RGB Mode

Parameter	Symbol	Condition	Min.	Typ.	Max.	Unit
CLKIN Frequency	Fclk	VDD = 1.8V ~3.6V	-	33.3	50	MHz
CLKIN Cycle Time	Tclk	-	20	30	-	ns
CLKIN Pulse Duty	Tcwh	Tclk= Tcwh + cwl	40	50	60	%
	Tcwl		40	50	-60	%
VSD to STV	Tstv	HV mode	-	24	-	H
DEN to STV	Tstv	DE mode	-	4	-	CLKIN
STV pulse width	Twstv	-	-	0.5	-	H
STV to CKV	Tckv	-	-	18	-	CLKIN
STV to OEV	Toev	-	-	2	-	CLKIN
CKV Pulse Width	Twckv	-	-	66	-	CLKIN
OEV Pulse Width	Twoev	-	-	50	-	CLKIN

6.6. Timing Waveform

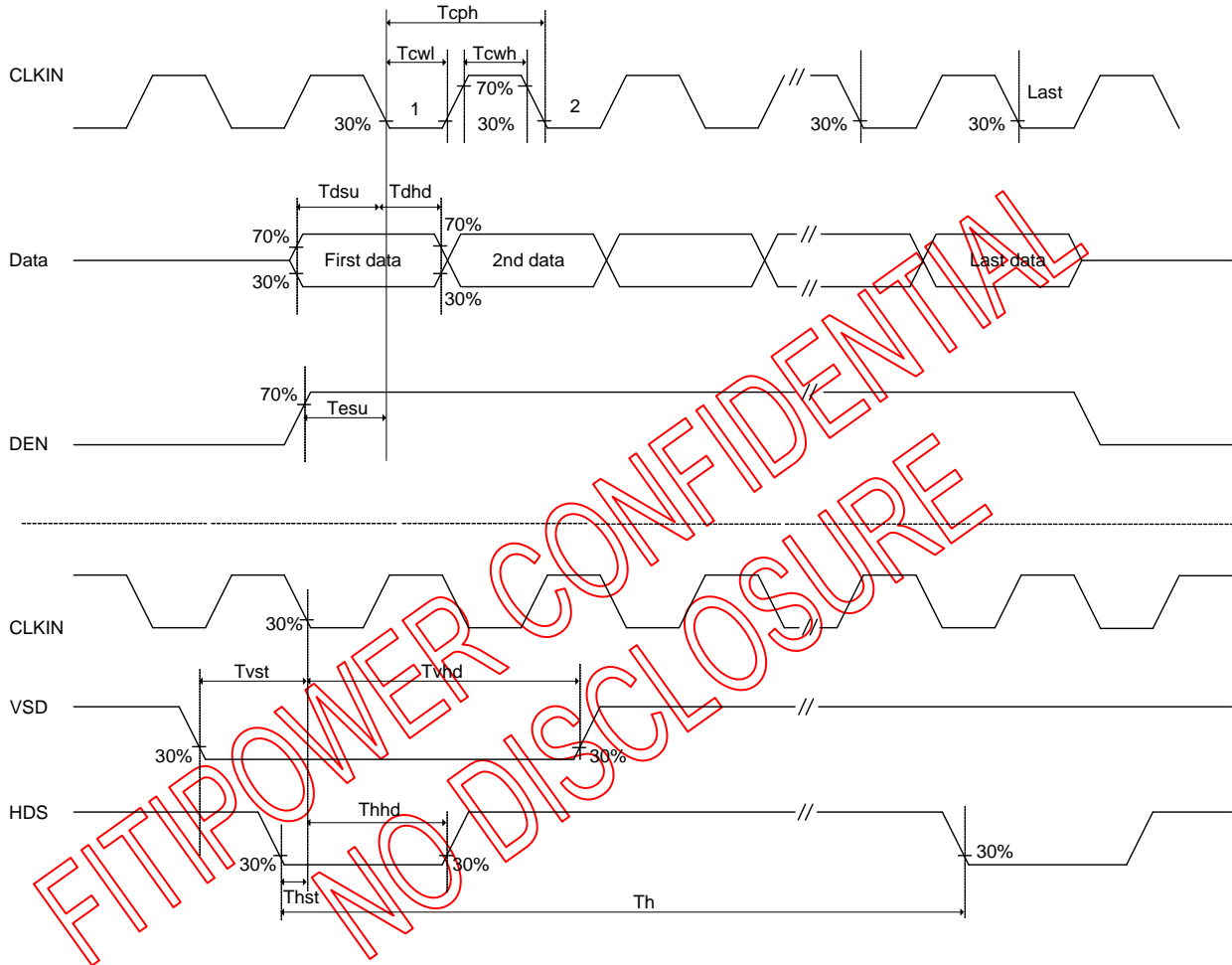

Input Clock and Data Timing Diagram

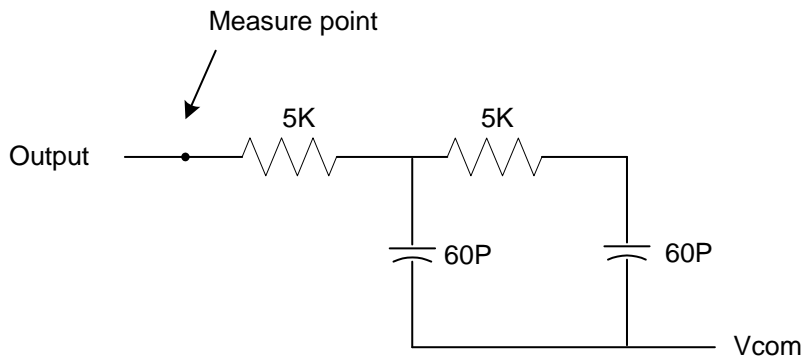

Output load condition

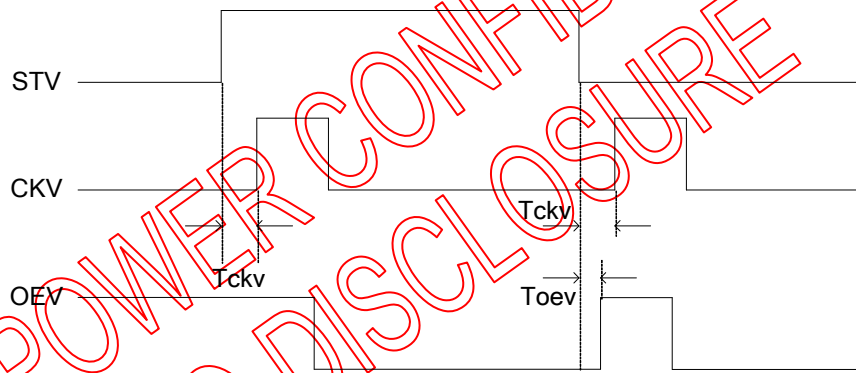
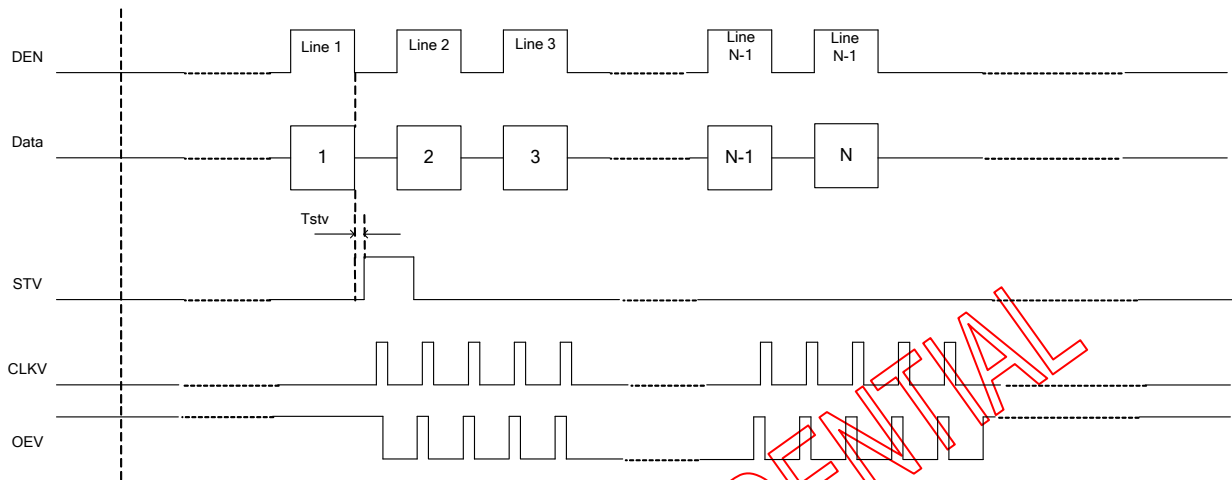

Vertical Timing Diagram DE

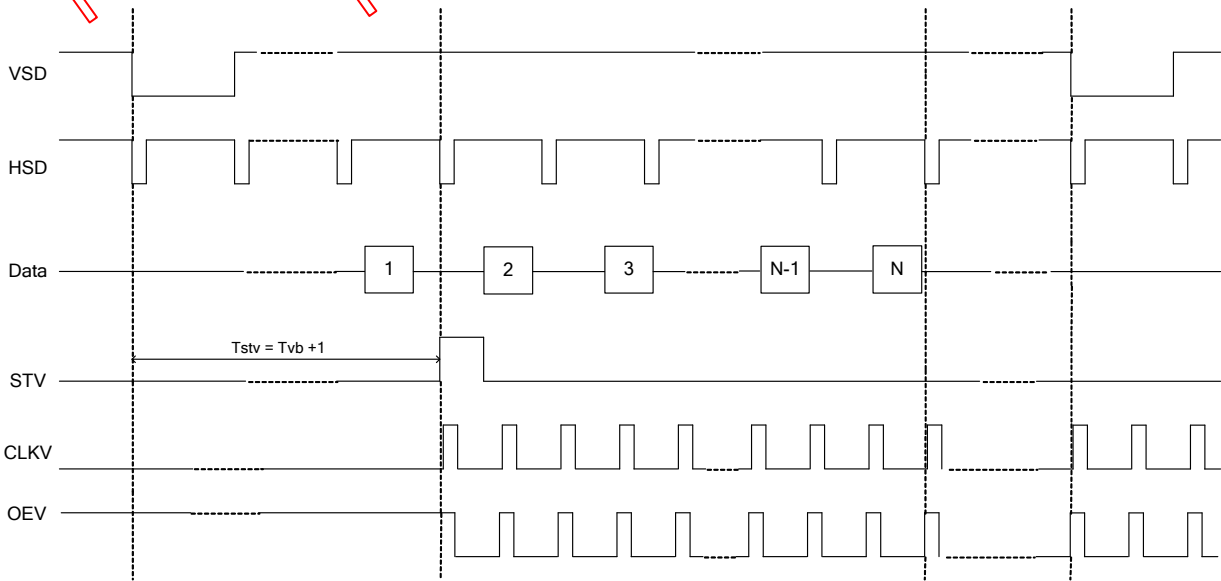

Vertical Timing Diagram HV

7. PAD DIAGRAM

Chip Size: 22487um x 882um (Include Scribe Line)

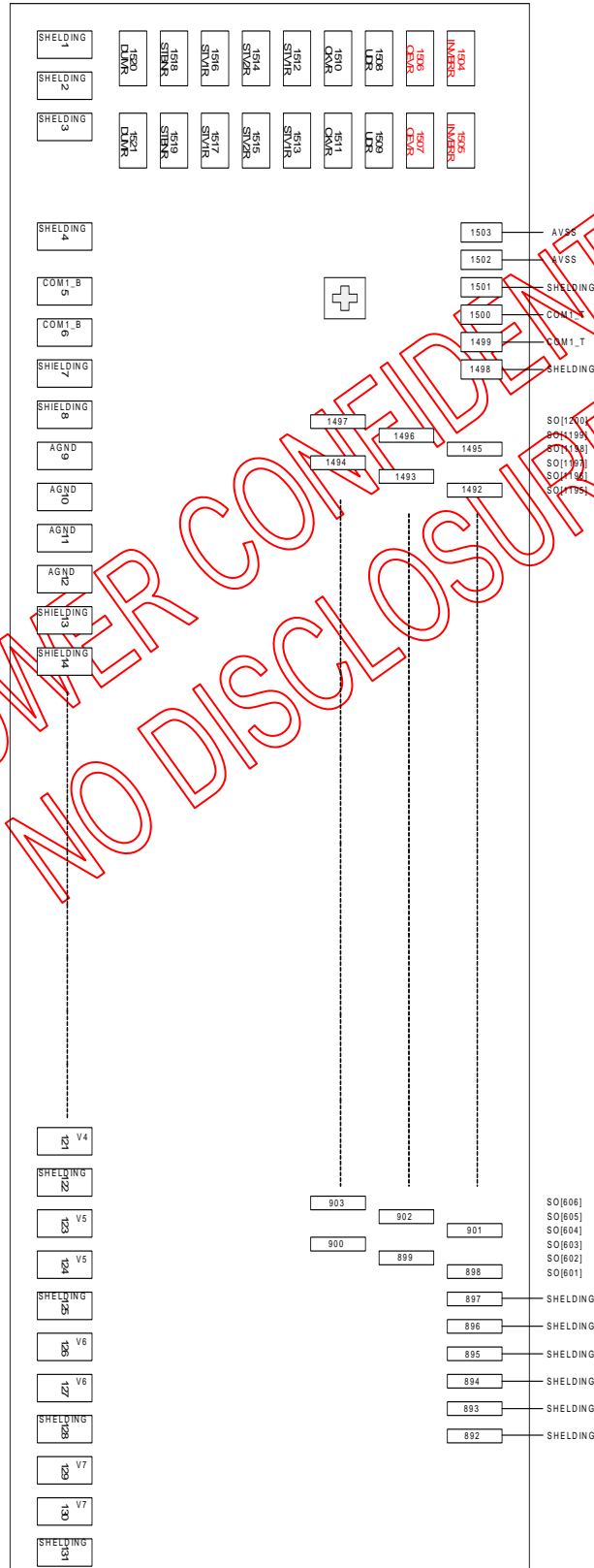

FITIPOWER CONFIDENTIAL
NO DISCLOSURE

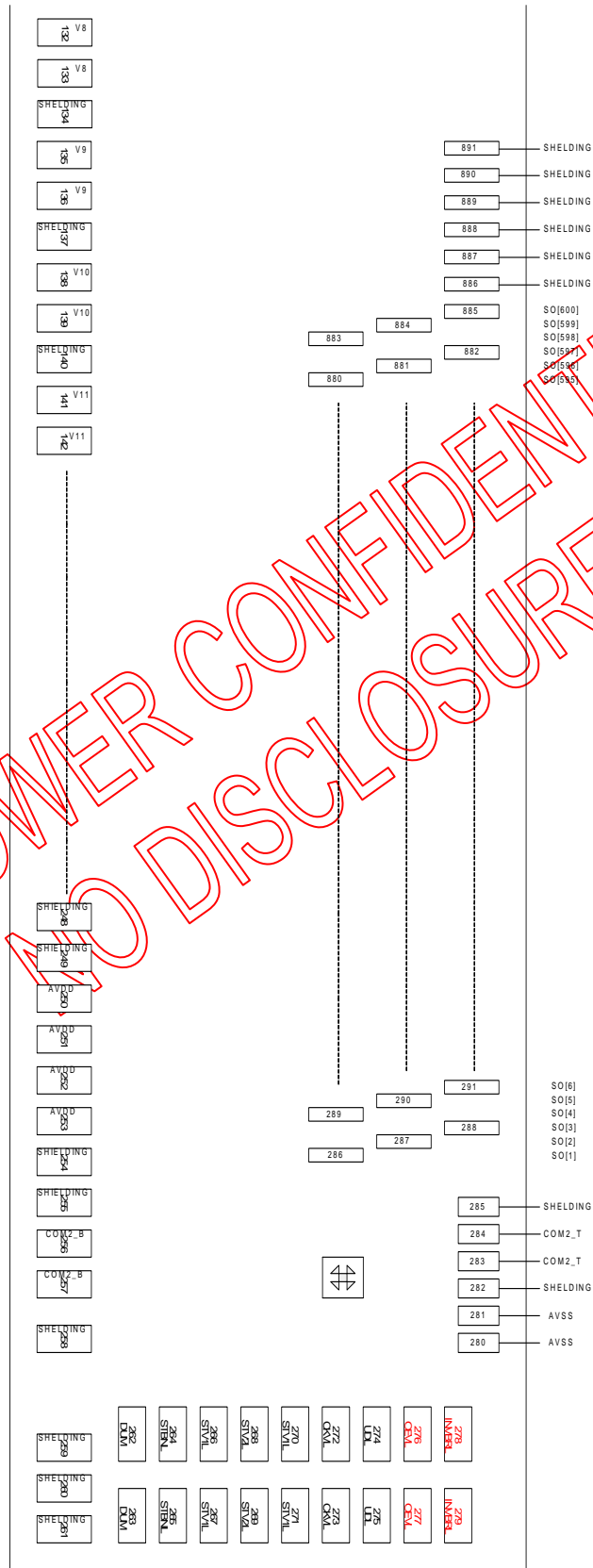

Note: The following parameters may be different for each customer.

Please contact fitipower for detail information.

Wafer Thickness: $400\mu\text{m} \pm 20\mu\text{m}$

Bump height: $9\mu\text{m}$

Co-planarity: within wafer $\leq 4\mu\text{m}$, within die $\leq 2\mu\text{m}$

Hardness of Bump: $60 \pm 15 \text{ Hv}$

Shear of Bump: $> 5.16\text{g}/\text{mil}^2$

IMPORTANT NOTICE

Contents in the document are subject to change without notice.

**FITIPOWER CONFIDENTIAL
NO DISCLOSURE**

7.1. CHIP OUTLINE DIMENSIONS

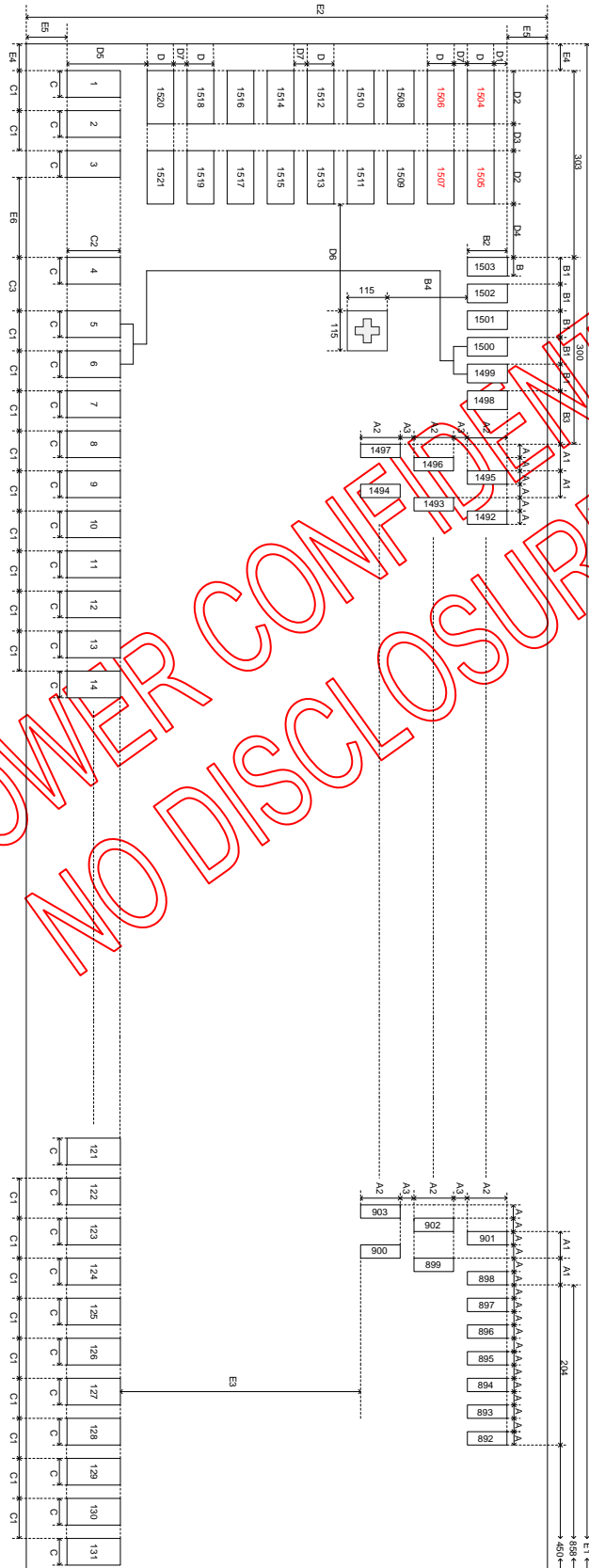

FITIPOWER CONFIDENTIAL
NO DISCLOSURE

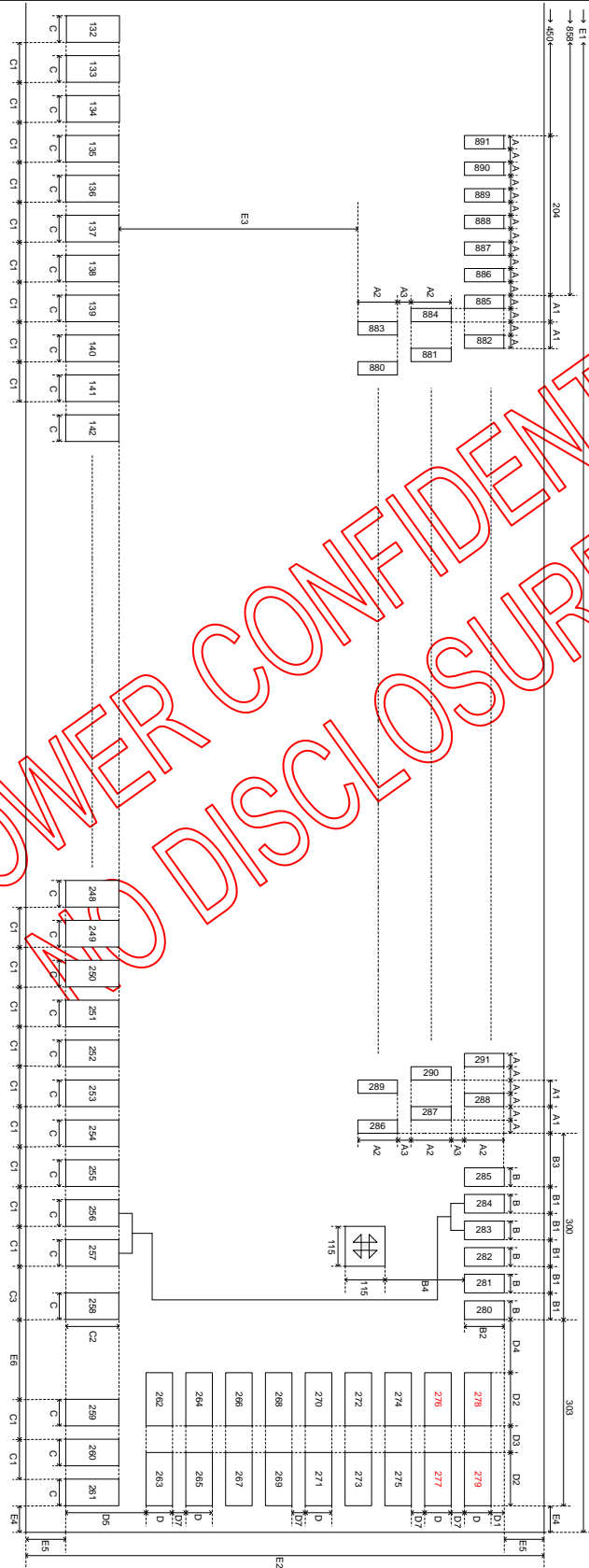

Symbol	Dimensions in um
A	17
A1	34
A2	85
A3	42.5
B	30
B1	50
B2	45
B3	50
B4	191.5
C	65
C1	85
C2	65
C3	115
D	30

Symbol	Dimensions in um
D1	15
D2	100
D3	30
D4	73
D5	170.5
D6	168.5
D7	50
E1	22487
E2	882
E3	428.5
E4	9.5
E5	8
E6	139.5

7.2. ALIGNMENT MARK DIMENSION (unit: um)

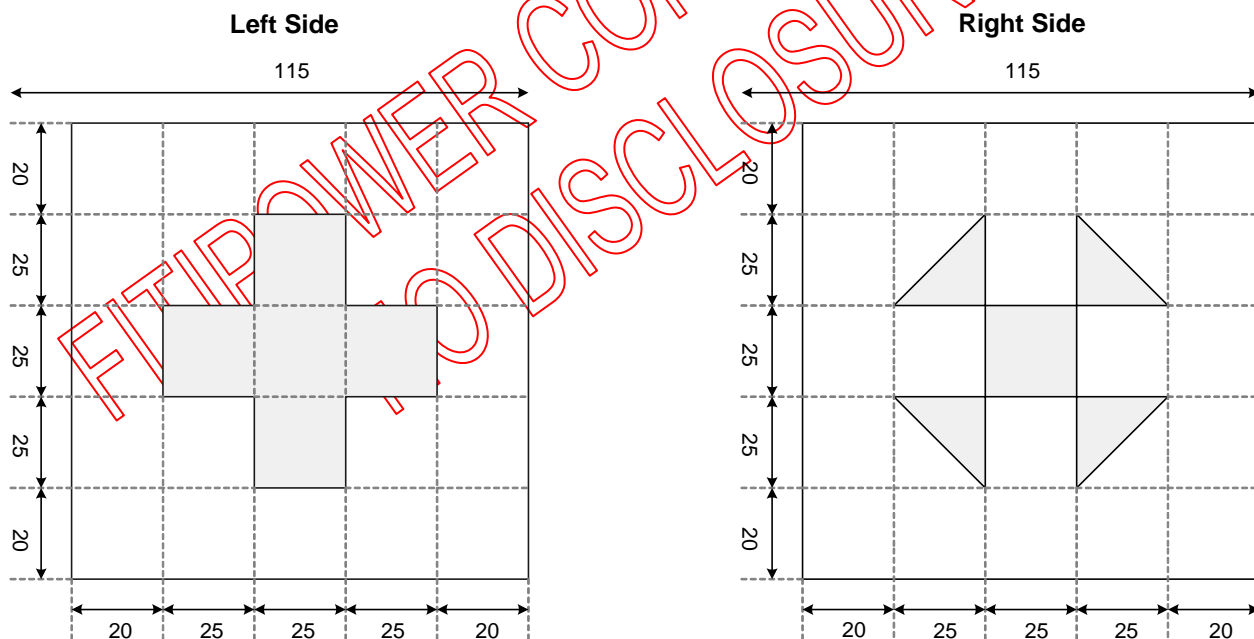

7.3. PAD COORDINATES

PAD No.	PAD Name	X	Y	BUMP SIZE (um x um)
1	SHIELDING	-11196.5	-395.5	65X65
2	SHIELDING	-11111.5	-395.5	65X65
3	SHIELDING	-11026.5	-395.5	65X65
4	SHIELDING	-10822.03	-395.5	65X65
5	COM1_B	-10707.06	-395.5	65X65
6	COM1_B	-10622.08	-395.5	65X65
7	SHIELDING	-10537.1	-395.5	65X65
8	SHIELDING	-10452.13	-395.5	65X65
9	AVSS	-10367.15	-395.5	65X65
10	AVSS	-10282.17	-395.5	65X65
11	AVSS	-10197.2	-395.5	65X65
12	AVSS	-10112.22	-395.5	65X65
13	SHIELDING	-10027.24	-395.5	65X65
14	SHIELDING	-9942.27	-395.5	65X65
15	SHIELDING	-9857.29	-395.5	65X65
16	SHIELDING	-9772.31	-395.5	65X65
17	SHIELDING	-9687.34	-395.5	65X65
18	SHIELDING	-9602.36	-395.5	65X65
19	TP0	-9517.38	-395.5	65X65
20	TP0	-9432.41	-395.5	65X65
21	TP1	-9347.43	-395.5	65X65
22	TP1	-9262.45	-395.5	65X65
23	TP2	-9177.48	-395.5	65X65
24	TP2	-9092.5	-395.5	65X65
25	TP3	-9007.52	-395.5	65X65
26	TP3	-8922.55	-395.5	65X65
27	TP4	-8837.57	-395.5	65X65
28	TP4	-8752.59	-395.5	65X65
29	TP5	-8667.62	-395.5	65X65
30	TP5	-8582.64	-395.5	65X65
31	SHIELDING	-8497.66	-395.5	65X65
32	TB0	-8412.69	-395.5	65X65
33	TB0	-8327.71	-395.5	65X65
34	SHIELDING	-8242.73	-395.5	65X65
35	TB1	-8157.76	-395.5	65X65
36	TB1	-8072.78	-395.5	65X65
37	SHIELDING	-7987.8	-395.5	65X65
38	SHIELDING	-7902.83	-395.5	65X65
39	SHIELDING	-7817.85	-395.5	65X65
40	SHIELDING	-7732.88	-395.5	65X65
41	TB2	-7647.9	-395.5	65X65
42	TB2	-7562.92	-395.5	65X65
43	SHIELDING	-7477.95	-395.5	65X65
44	TB3	-7392.97	-395.5	65X65
45	TB3	-7307.99	-395.5	65X65

PAD No.	PAD Name	X	Y	BUMP SIZE (um x um)
46	SHIELDING	-7223.02	-395.5	65X65
47	TB4	-7138.04	-395.5	65X65
48	TB4	-7053.06	-395.5	65X65
49	SHIELDING	-6968.09	-395.5	65X65
50	SHIELDING	-6883.11	-395.5	65X65
51	GOSEQ	-6798.13	-395.5	65X65
52	GOSEQ	-6713.16	-395.5	65X65
53	SHIELDING	-6628.18	-395.5	65X65
54	BIST	-6543.2	-395.5	65X65
55	BIST	-6458.23	-395.5	65X65
56	SHIELDING	-6373.25	-395.5	65X65
57	RES0	-6288.27	-395.5	65X65
58	RES0	-6203.3	-395.5	65X65
59	SHIELDING	-6118.32	-395.5	65X65
60	CFSEL	-6033.34	-395.5	65X65
61	CFSEL	-5948.37	-395.5	65X65
62	SHIELDING	-5863.39	-395.5	65X65
63	CLKPOL	-5778.41	-395.5	65X65
64	CLKPOL	-5693.44	-395.5	65X65
65	SHIELDING	-5608.46	-395.5	65X65
66	DITHB	-5523.48	-395.5	65X65
67	DITHB	-5438.51	-395.5	65X65
68	SHIELDING	-5353.53	-395.5	65X65
69	MODE	-5268.55	-395.5	65X65
70	MODE	-5183.58	-395.5	65X65
71	SHIELDING	-5098.6	-395.5	65X65
72	SHLR	-5013.62	-395.5	65X65
73	SHLR	-4928.65	-395.5	65X65
74	SHIELDING	-4843.67	-395.5	65X65
75	URDN	-4758.69	-395.5	65X65
76	UPDN	-4673.72	-395.5	65X65
77	SHIELDING	-4588.74	-395.5	65X65
78	STBYB	-4503.76	-395.5	65X65
79	STBYB	-4418.79	-395.5	65X65
80	SHIELDING	-4333.81	-395.5	65X65
81	RSTB	-4248.83	-395.5	65X65
82	RSTB	-4163.86	-395.5	65X65
83	SHIELDING	-4078.88	-395.5	65X65
84	BLKEN	-3993.9	-395.5	65X65
85	BLKEN	-3908.93	-395.5	65X65
86	SHIELDING	-3823.95	-395.5	65X65
87	VSET	-3738.97	-395.5	65X65
88	VSET	-3654	-395.5	65X65
89	TP6	-7223.02	-395.5	65X65
90	TP7	-7138.04	-395.5	65X65

PAD No.	PAD Name	X	Y	BUMP SIZE (um x um)
91	TP8	-3399.07	-395.5	65X65
92	TP9	-3314.09	-395.5	65X65
93	TP10	-3229.11	-395.5	65X65
94	TP11	-3144.14	-395.5	65X65
95	TP12	-3059.16	-395.5	65X65
96	TP13	-2974.18	-395.5	65X65
97	TP14	-2889.21	-395.5	65X65
98	TP15	-2804.23	-395.5	65X65
99	TP16	-2719.25	-395.5	65X65
100	TP17	-2634.28	-395.5	65X65
101	SHIELDING	-2549.3	-395.5	65X65
102	AVDD	-2464.32	-395.5	65X65
103	AVDD	-2379.35	-395.5	65X65
104	AVDD	-2294.37	-395.5	65X65
105	AVDD	-2209.39	-395.5	65X65
106	AVDD	-2124.42	-395.5	65X65
107	AVDD	-2039.44	-395.5	65X65
108	AVDD	-1954.46	-395.5	65X65
109	AVDD	-1869.49	-395.5	65X65
110	SHIELDING	-1784.51	-395.5	65X65
111	V1	-1699.53	-395.5	65X65
112	V1	-1614.56	-395.5	65X65
113	SHIELDING	-1529.58	-395.5	65X65
114	V2	-1444.6	-395.5	65X65
115	V2	-1359.63	-395.5	65X65
116	SHIELDING	-1274.65	-395.5	65X65
117	V3	-1189.67	-395.5	65X65
118	V3	-1104.7	-395.5	65X65
119	SHIELDING	-1019.72	-395.5	65X65
120	V4	-934.74	-395.5	65X65
121	V4	-849.77	-395.5	65X65
122	SHIELDING	-764.79	-395.5	65X65
123	V5	-679.81	-395.5	65X65
124	V5	-594.84	-395.5	65X65
125	SHIELDING	-509.86	-395.5	65X65
126	V6	-424.88	-395.5	65X65
127	V6	-339.91	-395.5	65X65
128	SHIELDING	-254.93	-395.5	65X65
129	V7	-169.95	-395.5	65X65
130	V7	-84.98	-395.5	65X65
131	SHIELDING	0	-395.5	65X65
132	V8	84.98	-395.5	65X65
133	V8	169.95	-395.5	65X65
134	SHIELDING	254.93	-395.5	65X65
135	V9	339.91	-395.5	65X65

PAD No.	PAD Name	X	Y	BUMP SIZE (um x um)
136	V9	424.88	-395.5	65X65
137	SHIELDING	509.86	-395.5	65X65
138	V10	594.84	-395.5	65X65
139	V10	679.81	-395.5	65X65
140	SHIELDING	764.79	-395.5	65X65
141	V11	849.77	-395.5	65X65
142	V11	934.74	-395.5	65X65
143	SHIELDING	1019.72	-395.5	65X65
144	V12	1104.7	-395.5	65X65
145	V12	1189.67	-395.5	65X65
146	SHIELDING	1274.65	-395.5	65X65
147	V13	1359.63	-395.5	65X65
148	V13	1444.6	-395.5	65X65
149	SHIELDING	1529.58	-395.5	65X65
150	V14	1614.56	-395.5	65X65
151	V14	1699.53	-395.5	65X65
152	SHIELDING	1784.51	-395.5	65X65
153	AVSS	1869.49	-395.5	65X65
154	AVSS	1954.46	-395.5	65X65
155	AVSS	2039.44	-395.5	65X65
156	AVSS	2124.42	-395.5	65X65
157	AVSS	2209.39	-395.5	65X65
158	AVSS	2294.37	-395.5	65X65
159	AVSS	2379.35	-395.5	65X65
160	AVSS	2464.32	-395.5	65X65
161	SHIELDING	2549.3	-395.5	65X65
162	SHIELDING	2634.28	-395.5	65X65
163	VSS	2719.25	-395.5	65X65
164	VSS	2804.23	-395.5	65X65
165	VSS	2889.21	-395.5	65X65
166	VSS	2974.18	-395.5	65X65
167	SHIELDING	3059.16	-395.5	65X65
168	SHIELDING	3144.14	-395.5	65X65
169	VDD	3229.11	-395.5	65X65
170	VDD	3314.09	-395.5	65X65
171	VDD	3399.07	-395.5	65X65
172	VDD	3484.04	-395.5	65X65
173	DASHD	3569.02	-395.5	65X65
174	VSD	3654	-395.5	65X65
175	VSD	3738.97	-395.5	65X65
176	DASHD	3823.95	-395.5	65X65
177	HSD	3908.93	-395.5	65X65
178	HSD	3993.9	-395.5	65X65
179	DASHD	4078.88	-395.5	65X65
180	DEN	4163.86	-395.5	65X65

PAD No.	PAD Name	X	Y	BUMP SIZE (um x um)
181	DEN	4248.83	-395.5	65X65
182	DASHD	4333.81	-395.5	65X65
183	CLKIN	4418.79	-395.5	65X65
184	CLKIN	4503.76	-395.5	65X65
185	DASHD	4588.74	-395.5	65X65
186	D27	4673.72	-395.5	65X65
187	D27	4758.69	-395.5	65X65
188	D26	4843.67	-395.5	65X65
189	D26	4928.65	-395.5	65X65
190	DASHD	5013.62	-395.5	65X65
191	D25	5098.6	-395.5	65X65
192	D25	5183.58	-395.5	65X65
193	D24	5268.55	-395.5	65X65
194	D24	5353.53	-395.5	65X65
195	DASHD	5438.51	-395.5	65X65
196	D23	5523.48	-395.5	65X65
197	D23	5608.46	-395.5	65X65
198	D22	5693.44	-395.5	65X65
199	D22	5778.41	-395.5	65X65
200	DASHD	5863.39	-395.5	65X65
201	D21	5948.37	-395.5	65X65
202	D21	6033.34	-395.5	65X65
203	D20	6118.32	-395.5	65X65
204	D20	6203.3	-395.5	65X65
205	DASHD	6288.27	-395.5	65X65
206	D17	6373.25	-395.5	65X65
207	D17	6458.23	-395.5	65X65
208	D16	6543.2	-395.5	65X65
209	D16	6628.18	-395.5	65X65
210	DASHD	6713.16	-395.5	65X65
211	D15	6798.13	-395.5	65X65
212	D15	6883.11	-395.5	65X65
213	D14	6968.09	-395.5	65X65
214	D14	7053.06	-395.5	65X65
215	DASHD	7138.04	-395.5	65X65
216	D13	7223.02	-395.5	65X65
217	D13	7307.99	-395.5	65X65
218	D12	7392.97	-395.5	65X65
219	D12	7477.95	-395.5	65X65
220	DASHD	7562.92	-395.5	65X65
221	D11	7647.9	-395.5	65X65
222	D11	7732.88	-395.5	65X65
223	D10	7817.85	-395.5	65X65
224	D10	7902.83	-395.5	65X65
225	DASHD	7987.8	-395.5	65X65

PAD No.	PAD Name	X	Y	BUMP SIZE (um x um)
226	D07	8072.78	-395.5	65X65
227	D07	8157.76	-395.5	65X65
228	D06	8242.73	-395.5	65X65
229	D06	8327.71	-395.5	65X65
230	DASHD	8412.69	-395.5	65X65
231	D05	8497.66	-395.5	65X65
232	D05	8582.64	-395.5	65X65
233	D04	8667.62	-395.5	65X65
234	D04	8752.59	-395.5	65X65
235	DASHD	8837.57	-395.5	65X65
236	D03	8922.55	-395.5	65X65
237	D03	9007.52	-395.5	65X65
238	D02	9092.5	-395.5	65X65
239	D02	9177.48	-395.5	65X65
240	DASHD	9262.45	-395.5	65X65
241	D01	9347.43	-395.5	65X65
242	D01	9432.41	-395.5	65X65
243	D00	9517.38	-395.5	65X65
244	D00	9602.36	-395.5	65X65
245	DASHD	9687.34	-395.5	65X65
246	SHIELDING	9772.31	-395.5	65X65
247	SHIELDING	9857.29	-395.5	65X65
248	SHIELDING	9942.27	-395.5	65X65
249	SHIELDING	10027.24	-395.5	65X65
250	AVDD	10112.22	-395.5	65X65
251	AVDD	10197.2	-395.5	65X65
252	AVDD	10282.17	-395.5	65X65
253	AVDD	10367.15	-395.5	65X65
254	SHIELDING	10452.13	-395.5	65X65
255	SHIELDING	10537.1	-395.5	65X65
256	COM2_B	10622.08	-395.5	65X65
257	COM2_B	10707.06	-395.5	65X65
258	SHIELDING	10822.03	-395.5	65X65
259	SHIELDING	11026.5	-395.5	65X65
260	SHIELDING	11111.5	-395.5	65X65
261	SHIELDING	11196.5	-395.5	65X65
262	DUM	11049	-242	100X30
263	DUM	11179	-242	100X30
264	STBNL	11049	-162	100X30
265	STBNL	11179	-162	100X30
266	STV1L	11049	-82	100X30
267	STV1L	11179	-82	100X30
268	STV2L	11049	-2	100X30
269	STV2L	11179	-2	100X30
270	STV1L	11049	78	100X30

PAD No.	PAD Name	X	Y	BUMP SIZE (um x um)
271	STV1L	11179	78	100X30
272	CKVL	11049	158	100X30
273	CKVL	11179	158	100X30
274	UDL	11049	238	100X30
275	UDL	11179	238	100X30
276	OEVL	11049	318	100X30
277	OEVL	11179	318	100X30
278	INVBRL	11049	398	100X30
279	INVBRL	11179	398	100X30
280	AVSS	10911	405.5	30X45
281	AVSS	10861.02	405.5	30X45
282	SHIELDING	10811.03	405.5	30X45
283	COM2_T	10761.04	405.5	30X45
284	COM2_T	10711.06	405.5	30X45
285	SHIELDING	10661.07	405.5	30X45
286	SO[1]	10617.58	118	17X85
287	SO[2]	10600.59	258	17X85
288	SO[3]	10583.59	385.5	17X85
289	SO[4]	10566.6	118	17X85
290	SO[5]	10549.6	258	17X85
291	SO[6]	10532.61	385.5	17X85
292	SO[7]	10515.61	118	17X85
293	SO[8]	10498.61	258	17X85
294	SO[9]	10481.62	385.5	17X85
295	SO[10]	10464.62	118	17X85
296	SO[11]	10447.63	258	17X85
297	SO[12]	10430.63	385.5	17X85
298	SO[13]	10413.64	118	17X85
299	SO[14]	10396.64	258	17X85
300	SO[15]	10379.65	385.5	17X85
301	SO[16]	10362.65	118	17X85
302	SO[17]	10345.66	258	17X85
303	SO[18]	10328.66	385.5	17X85
304	SO[19]	10311.67	118	17X85
305	SO[20]	10294.67	258	17X85
306	SO[21]	10277.68	385.5	17X85
307	SO[22]	10260.68	118	17X85
308	SO[23]	10243.69	258	17X85
309	SO[24]	10226.69	385.5	17X85
310	SO[25]	10209.69	118	17X85
311	SO[26]	10192.7	258	17X85
312	SO[27]	10175.7	385.5	17X85
313	SO[28]	10158.71	118	17X85
314	SO[29]	10141.71	258	17X85
315	SO[30]	10124.72	385.5	17X85

PAD No.	PAD Name	X	Y	BUMP SIZE (um x um)
316	SO[31]	10107.72	118	17X85
317	SO[32]	10090.73	258	17X85
318	SO[33]	10073.73	385.5	17X85
319	SO[34]	10056.74	118	17X85
320	SO[35]	10039.74	258	17X85
321	SO[36]	10022.75	385.5	17X85
322	SO[37]	10005.75	118	17X85
323	SO[38]	9988.76	258	17X85
324	SO[39]	9971.76	385.5	17X85
325	SO[40]	9954.76	118	17X85
326	SO[41]	9937.77	258	17X85
327	SO[42]	9920.77	385.5	17X85
328	SO[43]	9903.78	118	17X85
329	SO[44]	9886.78	258	17X85
330	SO[45]	9869.79	385.5	17X85
331	SO[46]	9852.79	118	17X85
332	SO[47]	9835.8	258	17X85
333	SO[48]	9818.8	385.5	17X85
334	SO[49]	9801.81	118	17X85
335	SO[50]	9784.81	258	17X85
336	SO[51]	9767.82	385.5	17X85
337	SO[52]	9750.82	118	17X85
338	SO[53]	9733.83	258	17X85
339	SO[54]	9716.83	385.5	17X85
340	SO[55]	9699.83	118	17X85
341	SO[56]	9682.84	258	17X85
342	SO[57]	9665.84	385.5	17X85
343	SO[58]	9648.85	118	17X85
344	SO[59]	9631.85	258	17X85
345	SO[60]	9614.86	385.5	17X85
346	SO[61]	9597.86	118	17X85
347	SO[62]	9580.87	258	17X85
348	SO[63]	9563.87	385.5	17X85
349	SO[64]	9546.88	118	17X85
350	SO[65]	9529.88	258	17X85
351	SO[66]	9512.89	385.5	17X85
352	SO[67]	9495.89	118	17X85
353	SO[68]	9478.9	258	17X85
354	SO[69]	9461.9	385.5	17X85
355	SO[70]	9444.9	118	17X85
356	SO[71]	9427.91	258	17X85
357	SO[72]	9410.91	385.5	17X85
358	SO[73]	9393.92	118	17X85
359	SO[74]	9376.92	258	17X85
360	SO[75]	9359.93	385.5	17X85

PAD No.	PAD Name	X	Y	BUMP SIZE (um x um)
361	SO[76]	9342.93	118	17X85
362	SO[77]	9325.94	258	17X85
363	SO[78]	9308.94	385.5	17X85
364	SO[79]	9291.95	118	17X85
365	SO[80]	9274.95	258	17X85
366	SO[81]	9257.96	385.5	17X85
367	SO[82]	9240.96	118	17X85
368	SO[83]	9223.97	258	17X85
369	SO[84]	9206.97	385.5	17X85
370	SO[85]	9189.97	118	17X85
371	SO[86]	9172.98	258	17X85
372	SO[87]	9155.98	385.5	17X85
373	SO[88]	9138.99	118	17X85
374	SO[89]	9121.99	258	17X85
375	SO[90]	9105	385.5	17X85
376	SO[91]	9088	118	17X85
377	SO[92]	9071.01	258	17X85
378	SO[93]	9054.01	385.5	17X85
379	SO[94]	9037.02	118	17X85
380	SO[95]	9020.02	258	17X85
381	SO[96]	9003.03	385.5	17X85
382	SO[97]	8986.03	118	17X85
383	SO[98]	8969.04	258	17X85
384	SO[99]	8952.04	385.5	17X85
385	SO[100]	8935.04	118	17X85
386	SO[101]	8918.05	258	17X85
387	SO[102]	8901.05	385.5	17X85
388	SO[103]	8884.06	118	17X85
389	SO[104]	8867.06	258	17X85
390	SO[105]	8850.07	385.5	17X85
391	SO[106]	8833.07	118	17X85
392	SO[107]	8816.08	258	17X85
393	SO[108]	8799.08	385.5	17X85
394	SO[109]	8782.09	118	17X85
395	SO[110]	8765.09	258	17X85
396	SO[111]	8748.1	385.5	17X85
397	SO[112]	8731.1	118	17X85
398	SO[113]	8714.11	258	17X85
399	SO[114]	8697.11	385.5	17X85
400	SO[115]	8680.11	118	17X85
401	SO[116]	8663.12	258	17X85
402	SO[117]	8646.12	385.5	17X85
403	SO[118]	8629.13	118	17X85
404	SO[119]	8612.13	258	17X85
405	SO[120]	8595.14	385.5	17X85

PAD No.	PAD Name	X	Y	BUMP SIZE (um x um)
406	SO[121]	8578.14	118	17X85
407	SO[122]	8561.15	258	17X85
408	SO[123]	8544.15	385.5	17X85
409	SO[124]	8527.16	118	17X85
410	SO[125]	8510.16	258	17X85
411	SO[126]	8493.17	385.5	17X85
412	SO[127]	8476.17	118	17X85
413	SO[128]	8459.18	258	17X85
414	SO[129]	8442.18	385.5	17X85
415	SO[130]	8425.18	118	17X85
416	SO[131]	8408.19	258	17X85
417	SO[132]	8391.19	385.5	17X85
418	SO[133]	8374.2	118	17X85
419	SO[134]	8357.2	258	17X85
420	SO[135]	8340.21	385.5	17X85
421	SO[136]	8323.21	118	17X85
422	SO[137]	8306.22	258	17X85
423	SO[138]	8289.22	385.5	17X85
424	SO[139]	8272.23	118	17X85
425	SO[140]	8255.23	258	17X85
426	SO[141]	8238.24	385.5	17X85
427	SO[142]	8221.24	118	17X85
428	SO[143]	8204.25	258	17X85
429	SO[144]	8187.25	385.5	17X85
430	SO[145]	8170.25	118	17X85
431	SO[146]	8153.26	258	17X85
432	SO[147]	8136.26	385.5	17X85
433	SO[148]	8119.27	118	17X85
434	SO[149]	8102.27	258	17X85
435	SO[150]	8085.28	385.5	17X85
436	SO[151]	8068.28	118	17X85
437	SO[152]	8051.29	258	17X85
438	SO[153]	8034.29	385.5	17X85
439	SO[154]	8017.3	118	17X85
440	SO[155]	8000.3	258	17X85
441	SO[156]	7983.31	385.5	17X85
442	SO[157]	7966.31	118	17X85
443	SO[158]	7949.32	258	17X85
444	SO[159]	7932.32	385.5	17X85
445	SO[160]	7915.32	118	17X85
446	SO[161]	7898.33	258	17X85
447	SO[162]	7881.33	385.5	17X85
448	SO[163]	7864.34	118	17X85
449	SO[164]	7847.34	258	17X85
450	SO[165]	7830.35	385.5	17X85

PAD No.	PAD Name	X	Y	BUMP SIZE (um x um)
451	SO[166]	7813.35	118	17X85
452	SO[167]	7796.36	258	17X85
453	SO[168]	7779.36	385.5	17X85
454	SO[169]	7762.37	118	17X85
455	SO[170]	7745.37	258	17X85
456	SO[171]	7728.38	385.5	17X85
457	SO[172]	7711.38	118	17X85
458	SO[173]	7694.39	258	17X85
459	SO[174]	7677.39	385.5	17X85
460	SO[175]	7660.39	118	17X85
461	SO[176]	7643.4	258	17X85
462	SO[177]	7626.4	385.5	17X85
463	SO[178]	7609.41	118	17X85
464	SO[179]	7592.41	258	17X85
465	SO[180]	7575.42	385.5	17X85
466	SO[181]	7558.42	118	17X85
467	SO[182]	7541.43	258	17X85
468	SO[183]	7524.43	385.5	17X85
469	SO[184]	7507.44	118	17X85
470	SO[185]	7490.44	258	17X85
471	SO[186]	7473.45	385.5	17X85
472	SO[187]	7456.45	118	17X85
473	SO[188]	7439.46	258	17X85
474	SO[189]	7422.46	385.5	17X85
475	SO[190]	7405.46	118	17X85
476	SO[191]	7388.47	258	17X85
477	SO[192]	7371.47	385.5	17X85
478	SO[193]	7354.48	118	17X85
479	SO[194]	7337.48	258	17X85
480	SO[195]	7320.49	385.5	17X85
481	SO[196]	7303.49	118	17X85
482	SO[197]	7286.5	258	17X85
483	SO[198]	7269.5	385.5	17X85
484	SO[199]	7252.51	118	17X85
485	SO[200]	7235.51	258	17X85
486	SO[201]	7218.52	385.5	17X85
487	SO[202]	7201.52	118	17X85
488	SO[203]	7184.53	258	17X85
489	SO[204]	7167.53	385.5	17X85
490	SO[205]	7150.54	118	17X85
491	SO[206]	7133.54	258	17X85
492	SO[207]	7116.54	385.5	17X85
493	SO[208]	7099.55	118	17X85
494	SO[209]	7082.55	258	17X85
495	SO[210]	7065.56	385.5	17X85

PAD No.	PAD Name	X	Y	BUMP SIZE (um x um)
496	SO[211]	7048.56	118	17X85
497	SO[212]	7031.57	258	17X85
498	SO[213]	7014.57	385.5	17X85
499	SO[214]	6997.58	118	17X85
500	SO[215]	6980.58	258	17X85
501	SO[216]	6963.59	385.5	17X85
502	SO[217]	6946.59	118	17X85
503	SO[218]	6929.6	258	17X85
504	SO[219]	6912.6	385.5	17X85
505	SO[220]	6895.61	118	17X85
506	SO[221]	6878.61	258	17X85
507	SO[222]	6861.61	385.5	17X85
508	SO[223]	6844.62	118	17X85
509	SO[224]	6827.62	258	17X85
510	SO[225]	6810.63	385.5	17X85
511	SO[226]	6793.63	118	17X85
512	SO[227]	6776.64	258	17X85
513	SO[228]	6759.64	385.5	17X85
514	SO[229]	6742.65	118	17X85
515	SO[230]	6725.65	258	17X85
516	SO[231]	6708.66	385.5	17X85
517	SO[232]	6691.66	118	17X85
518	SO[233]	6674.67	258	17X85
519	SO[234]	6657.67	385.5	17X85
520	SO[235]	6640.68	118	17X85
521	SO[236]	6623.68	258	17X85
522	SO[237]	6606.68	385.5	17X85
523	SO[238]	6589.69	118	17X85
524	SO[239]	6572.69	258	17X85
525	SO[240]	6555.7	385.5	17X85
526	SO[241]	6538.7	118	17X85
527	SO[242]	6521.71	258	17X85
528	SO[243]	6504.71	385.5	17X85
529	SO[244]	6487.72	118	17X85
530	SO[245]	6470.72	258	17X85
531	SO[246]	6453.73	385.5	17X85
532	SO[247]	6436.73	118	17X85
533	SO[248]	6419.74	258	17X85
534	SO[249]	6402.74	385.5	17X85
535	SO[250]	6385.75	118	17X85
536	SO[251]	6368.75	258	17X85
537	SO[252]	6351.75	385.5	17X85
538	SO[253]	6334.76	118	17X85
539	SO[254]	6317.76	258	17X85
540	SO[255]	6300.77	385.5	17X85

PAD No.	PAD Name	X	Y	BUMP SIZE (um x um)
541	SO[256]	6283.77	118	17X85
542	SO[257]	6266.78	258	17X85
543	SO[258]	6249.78	385.5	17X85
544	SO[259]	6232.79	118	17X85
545	SO[260]	6215.79	258	17X85
546	SO[261]	6198.8	385.5	17X85
547	SO[262]	6181.8	118	17X85
548	SO[263]	6164.81	258	17X85
549	SO[264]	6147.81	385.5	17X85
550	SO[265]	6130.82	118	17X85
551	SO[266]	6113.82	258	17X85
552	SO[267]	6096.82	385.5	17X85
553	SO[268]	6079.83	118	17X85
554	SO[269]	6062.83	258	17X85
555	SO[270]	6045.84	385.5	17X85
556	SO[271]	6028.84	118	17X85
557	SO[272]	6011.85	258	17X85
558	SO[273]	5994.85	385.5	17X85
559	SO[274]	5977.86	118	17X85
560	SO[275]	5960.86	258	17X85
561	SO[276]	5943.87	385.5	17X85
562	SO[277]	5926.87	118	17X85
563	SO[278]	5909.88	258	17X85
564	SO[279]	5892.88	385.5	17X85
565	SO[280]	5875.89	118	17X85
566	SO[281]	5858.89	258	17X85
567	SO[282]	5841.89	385.5	17X85
568	SO[283]	5824.9	118	17X85
569	SO[284]	5807.9	258	17X85
570	SO[285]	5790.91	385.5	17X85
571	SO[286]	5773.91	118	17X85
572	SO[287]	5756.92	258	17X85
573	SO[288]	5739.92	385.5	17X85
574	SO[289]	5722.93	118	17X85
575	SO[290]	5705.93	258	17X85
576	SO[291]	5688.94	385.5	17X85
577	SO[292]	5671.94	118	17X85
578	SO[293]	5654.95	258	17X85
579	SO[294]	5637.95	385.5	17X85
580	SO[295]	5620.96	118	17X85
581	SO[296]	5603.96	258	17X85
582	SO[297]	5586.96	385.5	17X85
583	SO[298]	5569.97	118	17X85
584	SO[299]	5552.97	258	17X85
585	SO[300]	5535.98	385.5	17X85

PAD No.	PAD Name	X	Y	BUMP SIZE (um x um)
586	SO[301]	5518.98	118	17X85
587	SO[302]	5501.99	258	17X85
588	SO[303]	5484.99	385.5	17X85
589	SO[304]	5468	118	17X85
590	SO[305]	5451	258	17X85
591	SO[306]	5434.01	385.5	17X85
592	SO[307]	5417.01	118	17X85
593	SO[308]	5400.02	258	17X85
594	SO[309]	5383.02	385.5	17X85
595	SO[310]	5366.03	118	17X85
596	SO[311]	5349.03	258	17X85
597	SO[312]	5332.03	385.5	17X85
598	SO[313]	5315.04	118	17X85
599	SO[314]	5298.04	258	17X85
600	SO[315]	5281.05	385.5	17X85
601	SO[316]	5264.05	118	17X85
602	SO[317]	5247.06	258	17X85
603	SO[318]	5230.06	385.5	17X85
604	SO[319]	5213.07	118	17X85
605	SO[320]	5196.07	258	17X85
606	SO[321]	5179.08	385.5	17X85
607	SO[322]	5162.08	118	17X85
608	SO[323]	5145.09	258	17X85
609	SO[324]	5128.09	385.5	17X85
610	SO[325]	5111.1	118	17X85
611	SO[326]	5094.1	258	17X85
612	SO[327]	5077.1	385.5	17X85
613	SO[328]	5060.11	118	17X85
614	SO[329]	5043.11	258	17X85
615	SO[330]	5026.12	385.5	17X85
616	SO[331]	5009.12	118	17X85
617	SO[332]	4992.13	258	17X85
618	SO[333]	4975.13	385.5	17X85
619	SO[334]	4958.14	118	17X85
620	SO[335]	4941.14	258	17X85
621	SO[336]	4924.15	385.5	17X85
622	SO[337]	4907.15	118	17X85
623	SO[338]	4890.16	258	17X85
624	SO[339]	4873.16	385.5	17X85
625	SO[340]	4856.17	118	17X85
626	SO[341]	4839.17	258	17X85
627	SO[342]	4822.17	385.5	17X85
628	SO[343]	4805.18	118	17X85
629	SO[344]	4788.18	258	17X85
630	SO[345]	4771.19	385.5	17X85

PAD No.	PAD Name	X	Y	BUMP SIZE (um x um)
631	SO[346]	4754.19	118	17X85
632	SO[347]	4737.2	258	17X85
633	SO[348]	4720.2	385.5	17X85
634	SO[349]	4703.21	118	17X85
635	SO[350]	4686.21	258	17X85
636	SO[351]	4669.22	385.5	17X85
637	SO[352]	4652.22	118	17X85
638	SO[353]	4635.23	258	17X85
639	SO[354]	4618.23	385.5	17X85
640	SO[355]	4601.24	118	17X85
641	SO[356]	4584.24	258	17X85
642	SO[357]	4567.24	385.5	17X85
643	SO[358]	4550.25	118	17X85
644	SO[359]	4533.25	258	17X85
645	SO[360]	4516.26	385.5	17X85
646	SO[361]	4499.26	118	17X85
647	SO[362]	4482.27	258	17X85
648	SO[363]	4465.27	385.5	17X85
649	SO[364]	4448.28	118	17X85
650	SO[365]	4431.28	258	17X85
651	SO[366]	4414.29	385.5	17X85
652	SO[367]	4397.29	118	17X85
653	SO[368]	4380.3	258	17X85
654	SO[369]	4363.3	385.5	17X85
655	SO[370]	4346.31	118	17X85
656	SO[371]	4329.31	258	17X85
657	SO[372]	4312.31	385.5	17X85
658	SO[373]	4295.32	118	17X85
659	SO[374]	4278.32	258	17X85
660	SO[375]	4261.33	385.5	17X85
661	SO[376]	4244.33	118	17X85
662	SO[377]	4227.34	258	17X85
663	SO[378]	4210.34	385.5	17X85
664	SO[379]	4193.35	118	17X85
665	SO[380]	4176.35	258	17X85
666	SO[381]	4159.36	385.5	17X85
667	SO[382]	4142.36	118	17X85
668	SO[383]	4125.37	258	17X85
669	SO[384]	4108.37	385.5	17X85
670	SO[385]	4091.38	118	17X85
671	SO[386]	4074.38	258	17X85
672	SO[387]	4057.39	385.5	17X85
673	SO[388]	4040.39	118	17X85
674	SO[389]	4023.39	258	17X85
675	SO[390]	4006.4	385.5	17X85

PAD No.	PAD Name	X	Y	BUMP SIZE (um x um)
676	SO[391]	3989.4	118	17X85
677	SO[392]	3972.41	258	17X85
678	SO[393]	3955.41	385.5	17X85
679	SO[394]	3938.42	118	17X85
680	SO[395]	3921.42	258	17X85
681	SO[396]	3904.43	385.5	17X85
682	SO[397]	3887.43	118	17X85
683	SO[398]	3870.44	258	17X85
684	SO[399]	3853.44	385.5	17X85
685	SO[400]	3836.45	118	17X85
686	SO[401]	3819.45	258	17X85
687	SO[402]	3802.46	385.5	17X85
688	SO[403]	3785.46	118	17X85
689	SO[404]	3768.46	258	17X85
690	SO[405]	3751.47	385.5	17X85
691	SO[406]	3734.47	118	17X85
692	SO[407]	3717.48	258	17X85
693	SO[408]	3700.48	385.5	17X85
694	SO[409]	3683.49	118	17X85
695	SO[410]	3666.49	258	17X85
696	SO[411]	3649.5	385.5	17X85
697	SO[412]	3632.5	118	17X85
698	SO[413]	3615.51	258	17X85
699	SO[414]	3598.51	385.5	17X85
700	SO[415]	3581.52	118	17X85
701	SO[416]	3564.52	258	17X85
702	SO[417]	3547.53	385.5	17X85
703	SO[418]	3530.53	118	17X85
704	SO[419]	3513.53	258	17X85
705	SO[420]	3496.54	385.5	17X85
706	SO[421]	3479.54	118	17X85
707	SO[422]	3462.55	258	17X85
708	SO[423]	3445.55	385.5	17X85
709	SO[424]	3428.56	118	17X85
710	SO[425]	3411.56	258	17X85
711	SO[426]	3394.57	385.5	17X85
712	SO[427]	3377.57	118	17X85
713	SO[428]	3360.58	258	17X85
714	SO[429]	3343.58	385.5	17X85
715	SO[430]	3326.59	118	17X85
716	SO[431]	3309.59	258	17X85
717	SO[432]	3292.6	385.5	17X85
718	SO[433]	3275.6	118	17X85
719	SO[434]	3258.6	258	17X85
720	SO[435]	3241.61	385.5	17X85

PAD No.	PAD Name	X	Y	BUMP SIZE (um x um)
721	SO[436]	3224.61	118	17X85
722	SO[437]	3207.62	258	17X85
723	SO[438]	3190.62	385.5	17X85
724	SO[439]	3173.63	118	17X85
725	SO[440]	3156.63	258	17X85
726	SO[441]	3139.64	385.5	17X85
727	SO[442]	3122.64	118	17X85
728	SO[443]	3105.65	258	17X85
729	SO[444]	3088.65	385.5	17X85
730	SO[445]	3071.66	118	17X85
731	SO[446]	3054.66	258	17X85
732	SO[447]	3037.67	385.5	17X85
733	SO[448]	3020.67	118	17X85
734	SO[449]	3003.67	258	17X85
735	SO[450]	2986.68	385.5	17X85
736	SO[451]	2969.68	118	17X85
737	SO[452]	2952.69	258	17X85
738	SO[453]	2935.69	385.5	17X85
739	SO[454]	2918.7	118	17X85
740	SO[455]	2901.7	258	17X85
741	SO[456]	2884.71	385.5	17X85
742	SO[457]	2867.71	118	17X85
743	SO[458]	2850.72	258	17X85
744	SO[459]	2833.72	385.5	17X85
745	SO[460]	2816.73	118	17X85
746	SO[461]	2799.73	258	17X85
747	SO[462]	2782.74	385.5	17X85
748	SO[463]	2765.74	118	17X85
749	SO[464]	2748.74	258	17X85
750	SO[465]	2731.75	385.5	17X85
751	SO[466]	2714.75	118	17X85
752	SO[467]	2697.76	258	17X85
753	SO[468]	2680.76	385.5	17X85
754	SO[469]	2663.77	118	17X85
755	SO[470]	2646.77	258	17X85
756	SO[471]	2629.78	385.5	17X85
757	SO[472]	2612.78	118	17X85
758	SO[473]	2595.79	258	17X85
759	SO[474]	2578.79	385.5	17X85
760	SO[475]	2561.8	118	17X85
761	SO[476]	2544.8	258	17X85
762	SO[477]	2527.81	385.5	17X85
763	SO[478]	2510.81	118	17X85
764	SO[479]	2493.81	258	17X85
765	SO[480]	2476.82	385.5	17X85

PAD No.	PAD Name	X	Y	BUMP SIZE (um x um)
766	SO[481]	2459.82	118	17X85
767	SO[482]	2442.83	258	17X85
768	SO[483]	2425.83	385.5	17X85
769	SO[484]	2408.84	118	17X85
770	SO[485]	2391.84	258	17X85
771	SO[486]	2374.85	385.5	17X85
772	SO[487]	2357.85	118	17X85
773	SO[488]	2340.86	258	17X85
774	SO[489]	2323.86	385.5	17X85
775	SO[490]	2306.87	118	17X85
776	SO[491]	2289.87	258	17X85
777	SO[492]	2272.88	385.5	17X85
778	SO[493]	2255.88	118	17X85
779	SO[494]	2238.88	258	17X85
780	SO[495]	2221.89	385.5	17X85
781	SO[496]	2204.89	118	17X85
782	SO[497]	2187.9	258	17X85
783	SO[498]	2170.9	385.5	17X85
784	SO[499]	2153.91	118	17X85
785	SO[500]	2136.91	258	17X85
786	SO[501]	2119.92	385.5	17X85
787	SO[502]	2102.92	118	17X85
788	SO[503]	2085.93	258	17X85
789	SO[504]	2068.93	385.5	17X85
790	SO[505]	2051.94	118	17X85
791	SO[506]	2034.94	258	17X85
792	SO[507]	2017.95	385.5	17X85
793	SO[508]	2000.95	118	17X85
794	SO[509]	1983.95	258	17X85
795	SO[510]	1966.96	385.5	17X85
796	SO[511]	1949.96	118	17X85
797	SO[512]	1932.97	258	17X85
798	SO[513]	1915.97	385.5	17X85
799	SO[514]	1898.98	118	17X85
800	SO[515]	1881.98	258	17X85
801	SO[516]	1864.99	385.5	17X85
802	SO[517]	1847.99	118	17X85
803	SO[518]	1831	258	17X85
804	SO[519]	1814	385.5	17X85
805	SO[520]	1797.01	118	17X85
806	SO[521]	1780.01	258	17X85
807	SO[522]	1763.02	385.5	17X85
808	SO[523]	1746.02	118	17X85
809	SO[524]	1729.02	258	17X85
810	SO[525]	1712.03	385.5	17X85

PAD No.	PAD Name	X	Y	BUMP SIZE (um x um)
811	SO[526]	1695.03	118	17X85
812	SO[527]	1678.04	258	17X85
813	SO[528]	1661.04	385.5	17X85
814	SO[529]	1644.05	118	17X85
815	SO[530]	1627.05	258	17X85
816	SO[531]	1610.06	385.5	17X85
817	SO[532]	1593.06	118	17X85
818	SO[533]	1576.07	258	17X85
819	SO[534]	1559.07	385.5	17X85
820	SO[535]	1542.08	118	17X85
821	SO[536]	1525.08	258	17X85
822	SO[537]	1508.09	385.5	17X85
823	SO[538]	1491.09	118	17X85
824	SO[539]	1474.09	258	17X85
825	SO[540]	1457.1	385.5	17X85
826	SO[541]	1440.1	118	17X85
827	SO[542]	1423.11	258	17X85
828	SO[543]	1406.11	385.5	17X85
829	SO[544]	1389.12	118	17X85
830	SO[545]	1372.12	258	17X85
831	SO[546]	1355.13	385.5	17X85
832	SO[547]	1338.13	118	17X85
833	SO[548]	1321.14	258	17X85
834	SO[549]	1304.14	385.5	17X85
835	SO[550]	1287.15	118	17X85
836	SO[551]	1270.15	258	17X85
837	SO[552]	1253.16	385.5	17X85
838	SO[553]	1236.16	118	17X85
839	SO[554]	1219.16	258	17X85
840	SO[555]	1202.17	385.5	17X85
841	SO[556]	1185.17	118	17X85
842	SO[557]	1168.18	258	17X85
843	SO[558]	1151.18	385.5	17X85
844	SO[559]	1134.19	118	17X85
845	SO[560]	1117.19	258	17X85
846	SO[561]	1100.2	385.5	17X85
847	SO[562]	1083.2	118	17X85
848	SO[563]	1066.21	258	17X85
849	SO[564]	1049.21	385.5	17X85
850	SO[565]	1032.22	118	17X85
851	SO[566]	1015.22	258	17X85
852	SO[567]	998.23	385.5	17X85
853	SO[568]	981.23	118	17X85
854	SO[569]	964.24	258	17X85
855	SO[570]	947.24	385.5	17X85

PAD No.	PAD Name	X	Y	BUMP SIZE (um x um)
856	SO[571]	930.24	118	17X85
857	SO[572]	913.25	258	17X85
858	SO[573]	896.25	385.5	17X85
859	SO[574]	879.26	118	17X85
860	SO[575]	862.26	258	17X85
861	SO[576]	845.27	385.5	17X85
862	SO[577]	828.27	118	17X85
863	SO[578]	811.28	258	17X85
864	SO[579]	794.28	385.5	17X85
865	SO[580]	777.29	118	17X85
866	SO[581]	760.29	258	17X85
867	SO[582]	743.3	385.5	17X85
868	SO[583]	726.3	118	17X85
869	SO[584]	709.31	258	17X85
870	SO[585]	692.31	385.5	17X85
871	SO[586]	675.31	118	17X85
872	SO[587]	658.32	258	17X85
873	SO[588]	641.32	385.5	17X85
874	SO[589]	624.33	118	17X85
875	SO[590]	607.33	258	17X85
876	SO[591]	590.34	385.5	17X85
877	SO[592]	573.34	118	17X85
878	SO[593]	556.35	258	17X85
879	SO[594]	539.35	385.5	17X85
880	SO[595]	522.36	118	17X85
881	SO[596]	505.36	258	17X85
882	SO[597]	488.37	385.5	17X85
883	SO[598]	471.37	118	17X85
884	SO[599]	454.38	258	17X85
885	SO[600]	437.38	385.5	17X85
886	SHIELDING	403.39	385.5	17X85
887	SHIELDING	369.4	385.5	17X85
888	SHIELDING	335.41	385.5	17X85
889	SHIELDING	301.42	385.5	17X85
890	SHIELDING	267.43	385.5	17X85
891	SHIELDING	233.44	385.5	17X85
892	SHIELDING	-233.44	385.5	17X85
893	SHIELDING	-267.43	385.5	17X85
894	SHIELDING	-301.42	385.5	17X85
895	SHIELDING	-335.41	385.5	17X85
896	SHIELDING	-369.4	385.5	17X85
897	SHIELDING	-403.39	385.5	17X85
898	SO[601]	-437.38	385.5	17X85
899	SO[602]	-454.38	258	17X85
900	SO[603]	-471.37	118	17X85

PAD No.	PAD Name	X	Y	BUMP SIZE (um x um)
901	SO[604]	-488.37	385.5	17X85
902	SO[605]	-505.36	258	17X85
903	SO[606]	-522.36	118	17X85
904	SO[607]	-539.35	385.5	17X85
905	SO[608]	-556.35	258	17X85
906	SO[609]	-573.34	118	17X85
907	SO[610]	-590.34	385.5	17X85
908	SO[611]	-607.33	258	17X85
909	SO[612]	-624.33	118	17X85
910	SO[613]	-641.32	385.5	17X85
911	SO[614]	-658.32	258	17X85
912	SO[615]	-675.31	118	17X85
913	SO[616]	-692.31	385.5	17X85
914	SO[617]	-709.31	258	17X85
915	SO[618]	-726.3	118	17X85
916	SO[619]	-743.3	385.5	17X85
917	SO[620]	-760.29	258	17X85
918	SO[621]	-777.29	118	17X85
919	SO[622]	-794.28	385.5	17X85
920	SO[623]	-811.28	258	17X85
921	SO[624]	-828.27	118	17X85
922	SO[625]	-845.27	385.5	17X85
923	SO[626]	-862.26	258	17X85
924	SO[627]	-879.26	118	17X85
925	SO[628]	-896.25	385.5	17X85
926	SO[629]	-913.25	258	17X85
927	SO[630]	-930.24	118	17X85
928	SO[631]	-947.24	385.5	17X85
929	SO[632]	-964.24	258	17X85
930	SO[633]	-981.23	118	17X85
931	SO[634]	-998.23	385.5	17X85
932	SO[635]	-1015.22	258	17X85
933	SO[636]	-1032.22	118	17X85
934	SO[637]	-1049.21	385.5	17X85
935	SO[638]	-1066.21	258	17X85
936	SO[639]	-1083.2	118	17X85
937	SO[640]	-1100.2	385.5	17X85
938	SO[641]	-1117.19	258	17X85
939	SO[642]	-1134.19	118	17X85
940	SO[643]	-1151.18	385.5	17X85
941	SO[644]	-1168.18	258	17X85
942	SO[645]	-1185.17	118	17X85
943	SO[646]	-1202.17	385.5	17X85
944	SO[647]	-1219.16	258	17X85
945	SO[648]	-1236.16	118	17X85

PAD No.	PAD Name	X	Y	BUMP SIZE (um x um)
946	SO[649]	-1253.16	385.5	17X85
947	SO[650]	-1270.15	258	17X85
948	SO[651]	-1287.15	118	17X85
949	SO[652]	-1304.14	385.5	17X85
950	SO[653]	-1321.14	258	17X85
951	SO[654]	-1338.13	118	17X85
952	SO[655]	-1355.13	385.5	17X85
953	SO[656]	-1372.12	258	17X85
954	SO[657]	-1389.12	118	17X85
955	SO[658]	-1406.11	385.5	17X85
956	SO[659]	-1423.11	258	17X85
957	SO[660]	-1440.1	118	17X85
958	SO[661]	-1457.1	385.5	17X85
959	SO[662]	-1474.09	258	17X85
960	SO[663]	-1491.09	118	17X85
961	SO[664]	-1508.09	385.5	17X85
962	SO[665]	-1525.08	258	17X85
963	SO[666]	-1542.08	118	17X85
964	SO[667]	-1559.07	385.5	17X85
965	SO[668]	-1576.07	258	17X85
966	SO[669]	-1593.06	118	17X85
967	SO[670]	-1610.06	385.5	17X85
968	SO[671]	-1627.05	258	17X85
969	SO[672]	-1644.05	118	17X85
970	SO[673]	-1661.04	385.5	17X85
971	SO[674]	-1678.04	258	17X85
972	SO[675]	-1695.03	118	17X85
973	SO[676]	-1712.03	385.5	17X85
974	SO[677]	-1729.02	258	17X85
975	SO[678]	-1746.02	118	17X85
976	SO[679]	-1763.02	385.5	17X85
977	SO[680]	-1780.01	258	17X85
978	SO[681]	-1797.01	118	17X85
979	SO[682]	-1814	385.5	17X85
980	SO[683]	-1831	258	17X85
981	SO[684]	-1847.99	118	17X85
982	SO[685]	-1864.99	385.5	17X85
983	SO[686]	-1881.98	258	17X85
984	SO[687]	-1898.98	118	17X85
985	SO[688]	-1915.97	385.5	17X85
986	SO[689]	-1932.97	258	17X85
987	SO[690]	-1949.96	118	17X85
988	SO[691]	-1966.96	385.5	17X85
989	SO[692]	-1983.95	258	17X85
990	SO[693]	-2000.95	118	17X85

PAD No.	PAD Name	X	Y	BUMP SIZE (um x um)
991	SO[694]	-2017.95	385.5	17X85
992	SO[695]	-2034.94	258	17X85
993	SO[696]	-2051.94	118	17X85
994	SO[697]	-2068.93	385.5	17X85
995	SO[698]	-2085.93	258	17X85
996	SO[699]	-2102.92	118	17X85
997	SO[700]	-2119.92	385.5	17X85
998	SO[701]	-2136.91	258	17X85
999	SO[702]	-2153.91	118	17X85
1000	SO[703]	-2170.9	385.5	17X85
1001	SO[704]	-2187.9	258	17X85
1002	SO[705]	-2204.89	118	17X85
1003	SO[706]	-2221.89	385.5	17X85
1004	SO[707]	-2238.88	258	17X85
1005	SO[708]	-2255.88	118	17X85
1006	SO[709]	-2272.88	385.5	17X85
1007	SO[710]	-2289.87	258	17X85
1008	SO[711]	-2306.87	118	17X85
1009	SO[712]	-2323.86	385.5	17X85
1010	SO[713]	-2340.86	258	17X85
1011	SO[714]	-2357.85	118	17X85
1012	SO[715]	-2374.85	385.5	17X85
1013	SO[716]	-2391.84	258	17X85
1014	SO[717]	-2408.84	118	17X85
1015	SO[718]	-2425.83	385.5	17X85
1016	SO[719]	-2442.83	258	17X85
1017	SO[720]	-2459.82	118	17X85
1018	SO[721]	-2476.82	385.5	17X85
1019	SO[722]	-2493.81	258	17X85
1020	SO[723]	-2510.81	118	17X85
1021	SO[724]	-2527.81	385.5	17X85
1022	SO[725]	-2544.8	258	17X85
1023	SO[726]	-2561.8	118	17X85
1024	SO[727]	-2578.79	385.5	17X85
1025	SO[728]	-2595.79	258	17X85
1026	SO[729]	-2612.78	118	17X85
1027	SO[730]	-2629.78	385.5	17X85
1028	SO[731]	-2646.77	258	17X85
1029	SO[732]	-2663.77	118	17X85
1030	SO[733]	-2680.76	385.5	17X85
1031	SO[734]	-2697.76	258	17X85
1032	SO[735]	-2714.75	118	17X85
1033	SO[736]	-2731.75	385.5	17X85
1034	SO[737]	-2748.74	258	17X85
1035	SO[738]	-2765.74	118	17X85

PAD No.	PAD Name	X	Y	BUMP SIZE (um x um)
1036	SO[739]	-2782.74	385.5	17X85
1037	SO[740]	-2799.73	258	17X85
1038	SO[741]	-2816.73	118	17X85
1039	SO[742]	-2833.72	385.5	17X85
1040	SO[743]	-2850.72	258	17X85
1041	SO[744]	-2867.71	118	17X85
1042	SO[745]	-2884.71	385.5	17X85
1043	SO[746]	-2901.7	258	17X85
1044	SO[747]	-2918.7	118	17X85
1045	SO[748]	-2935.69	385.5	17X85
1046	SO[749]	-2952.69	258	17X85
1047	SO[750]	-2969.68	118	17X85
1048	SO[751]	-2986.68	385.5	17X85
1049	SO[752]	-3003.67	258	17X85
1050	SO[753]	-3020.67	118	17X85
1051	SO[754]	-3037.67	385.5	17X85
1052	SO[755]	-3054.66	258	17X85
1053	SO[756]	-3071.66	118	17X85
1054	SO[757]	-3088.65	385.5	17X85
1055	SO[758]	-3105.65	258	17X85
1056	SO[759]	-3122.64	118	17X85
1057	SO[760]	-3139.64	385.5	17X85
1058	SO[761]	-3156.63	258	17X85
1059	SO[762]	-3173.63	118	17X85
1060	SO[763]	-3190.62	385.5	17X85
1061	SO[764]	-3207.62	258	17X85
1062	SO[765]	-3224.61	118	17X85
1063	SO[766]	-3241.61	385.5	17X85
1064	SO[767]	-3258.6	258	17X85
1065	SO[768]	-3275.6	118	17X85
1066	SO[769]	-3292.6	385.5	17X85
1067	SO[770]	-3309.59	258	17X85
1068	SO[771]	-3326.59	118	17X85
1069	SO[772]	-3343.58	385.5	17X85
1070	SO[773]	-3360.58	258	17X85
1071	SO[774]	-3377.57	118	17X85
1072	SO[775]	-3394.57	385.5	17X85
1073	SO[776]	-3411.56	258	17X85
1074	SO[777]	-3428.56	118	17X85
1075	SO[778]	-3445.55	385.5	17X85
1076	SO[779]	-3462.55	258	17X85
1077	SO[780]	-3479.54	118	17X85
1078	SO[781]	-3496.54	385.5	17X85
1079	SO[782]	-3513.53	258	17X85
1080	SO[783]	-3530.53	118	17X85

PAD No.	PAD Name	X	Y	BUMP SIZE (um x um)
1081	SO[784]	-3547.53	385.5	17X85
1082	SO[785]	-3564.52	258	17X85
1083	SO[786]	-3581.52	118	17X85
1084	SO[787]	-3598.51	385.5	17X85
1085	SO[788]	-3615.51	258	17X85
1086	SO[789]	-3632.5	118	17X85
1087	SO[790]	-3649.5	385.5	17X85
1088	SO[791]	-3666.49	258	17X85
1089	SO[792]	-3683.49	118	17X85
1090	SO[793]	-3700.48	385.5	17X85
1091	SO[794]	-3717.48	258	17X85
1092	SO[795]	-3734.47	118	17X85
1093	SO[796]	-3751.47	385.5	17X85
1094	SO[797]	-3768.46	258	17X85
1095	SO[798]	-3785.46	118	17X85
1096	SO[799]	-3802.46	385.5	17X85
1097	SO[800]	-3819.45	258	17X85
1098	SO[801]	-3836.45	118	17X85
1099	SO[802]	-3853.44	385.5	17X85
1100	SO[803]	-3870.44	258	17X85
1101	SO[804]	-3887.43	118	17X85
1102	SO[805]	-3904.43	385.5	17X85
1103	SO[806]	-3921.42	258	17X85
1104	SO[807]	-3938.42	118	17X85
1105	SO[808]	-3955.41	385.5	17X85
1106	SO[809]	-3972.41	258	17X85
1107	SO[810]	-3989.4	118	17X85
1108	SO[811]	-4006.4	385.5	17X85
1109	SO[812]	-4023.39	258	17X85
1110	SO[813]	-4040.39	118	17X85
1111	SO[814]	-4057.39	385.5	17X85
1112	SO[815]	-4074.38	258	17X85
1113	SO[816]	-4091.38	118	17X85
1114	SO[817]	-4108.37	385.5	17X85
1115	SO[818]	-4125.37	258	17X85
1116	SO[819]	-4142.36	118	17X85
1117	SO[820]	-4159.36	385.5	17X85
1118	SO[821]	-4176.35	258	17X85
1119	SO[822]	-4193.35	118	17X85
1120	SO[823]	-4210.34	385.5	17X85
1121	SO[824]	-4227.34	258	17X85
1122	SO[825]	-4244.33	118	17X85
1123	SO[826]	-4261.33	385.5	17X85
1124	SO[827]	-4278.32	258	17X85
1125	SO[828]	-4295.32	118	17X85

PAD No.	PAD Name	X	Y	BUMP SIZE (um x um)
1126	SO[829]	-4312.31	385.5	17X85
1127	SO[830]	-4329.31	258	17X85
1128	SO[831]	-4346.31	118	17X85
1129	SO[832]	-4363.3	385.5	17X85
1130	SO[833]	-4380.3	258	17X85
1131	SO[834]	-4397.29	118	17X85
1132	SO[835]	-4414.29	385.5	17X85
1133	SO[836]	-4431.28	258	17X85
1134	SO[837]	-4448.28	118	17X85
1135	SO[838]	-4465.27	385.5	17X85
1136	SO[839]	-4482.27	258	17X85
1137	SO[840]	-4499.26	118	17X85
1138	SO[841]	-4516.26	385.5	17X85
1139	SO[842]	-4533.25	258	17X85
1140	SO[843]	-4550.25	118	17X85
1141	SO[844]	-4567.24	385.5	17X85
1142	SO[845]	-4584.24	258	17X85
1143	SO[846]	-4601.24	118	17X85
1144	SO[847]	-4618.23	385.5	17X85
1145	SO[848]	-4635.23	258	17X85
1146	SO[849]	-4652.22	118	17X85
1147	SO[850]	-4669.22	385.5	17X85
1148	SO[851]	-4686.21	258	17X85
1149	SO[852]	-4703.21	118	17X85
1150	SO[853]	-4720.2	385.5	17X85
1151	SO[854]	-4737.2	258	17X85
1152	SO[855]	-4754.19	118	17X85
1153	SO[856]	-4771.19	385.5	17X85
1154	SO[857]	-4788.18	258	17X85
1155	SO[858]	-4805.18	118	17X85
1156	SO[859]	-4822.17	385.5	17X85
1157	SO[860]	-4839.17	258	17X85
1158	SO[861]	-4856.17	118	17X85
1159	SO[862]	-4873.16	385.5	17X85
1160	SO[863]	-4890.16	258	17X85
1161	SO[864]	-4907.15	118	17X85
1162	SO[865]	-4924.15	385.5	17X85
1163	SO[866]	-4941.14	258	17X85
1164	SO[867]	-4958.14	118	17X85
1165	SO[868]	-4975.13	385.5	17X85
1166	SO[869]	-4992.13	258	17X85
1167	SO[870]	-5009.12	118	17X85
1168	SO[871]	-5026.12	385.5	17X85
1169	SO[872]	-5043.11	258	17X85
1170	SO[873]	-5060.11	118	17X85

PAD No.	PAD Name	X	Y	BUMP SIZE (um x um)
1171	SO[874]	-5077.1	385.5	17X85
1172	SO[875]	-5094.1	258	17X85
1173	SO[876]	-5111.1	118	17X85
1174	SO[877]	-5128.09	385.5	17X85
1175	SO[878]	-5145.09	258	17X85
1176	SO[879]	-5162.08	118	17X85
1177	SO[880]	-5179.08	385.5	17X85
1178	SO[881]	-5196.07	258	17X85
1179	SO[882]	-5213.07	118	17X85
1180	SO[883]	-5230.06	385.5	17X85
1181	SO[884]	-5247.06	258	17X85
1182	SO[885]	-5264.05	118	17X85
1183	SO[886]	-5281.05	385.5	17X85
1184	SO[887]	-5298.04	258	17X85
1185	SO[888]	-5315.04	118	17X85
1186	SO[889]	-5332.03	385.5	17X85
1187	SO[890]	-5349.03	258	17X85
1188	SO[891]	-5366.03	118	17X85
1189	SO[892]	-5383.02	385.5	17X85
1190	SO[893]	-5400.02	258	17X85
1191	SO[894]	-5417.01	118	17X85
1192	SO[895]	-5434.01	385.5	17X85
1193	SO[896]	-5451	258	17X85
1194	SO[897]	-5468	118	17X85
1195	SO[898]	-5484.99	385.5	17X85
1196	SO[899]	-5501.99	258	17X85
1197	SO[900]	-5518.98	118	17X85
1198	SO[901]	-5535.98	385.5	17X85
1199	SO[902]	-5552.97	258	17X85
1200	SO[903]	-5569.97	118	17X85
1201	SO[904]	-5586.96	385.5	17X85
1202	SO[905]	-5603.96	258	17X85
1203	SO[906]	-5620.96	118	17X85
1204	SO[907]	-5637.95	385.5	17X85
1205	SO[908]	-5654.95	258	17X85
1206	SO[909]	-5671.94	118	17X85
1207	SO[910]	-5688.94	385.5	17X85
1208	SO[911]	-5705.93	258	17X85
1209	SO[912]	-5722.93	118	17X85
1210	SO[913]	-5739.92	385.5	17X85
1211	SO[914]	-5756.92	258	17X85
1212	SO[915]	-5773.91	118	17X85
1213	SO[916]	-5790.91	385.5	17X85
1214	SO[917]	-5807.9	258	17X85
1215	SO[918]	-5824.9	118	17X85

PAD No.	PAD Name	X	Y	BUMP SIZE (um x um)
1216	SO[919]	-5841.89	385.5	17X85
1217	SO[920]	-5858.89	258	17X85
1218	SO[921]	-5875.89	118	17X85
1219	SO[922]	-5892.88	385.5	17X85
1220	SO[923]	-5909.88	258	17X85
1221	SO[924]	-5926.87	118	17X85
1222	SO[925]	-5943.87	385.5	17X85
1223	SO[926]	-5960.86	258	17X85
1224	SO[927]	-5977.86	118	17X85
1225	SO[928]	-5994.85	385.5	17X85
1226	SO[929]	-6011.85	258	17X85
1227	SO[930]	-6028.84	118	17X85
1228	SO[931]	-6045.84	385.5	17X85
1229	SO[932]	-6062.83	258	17X85
1230	SO[933]	-6079.83	118	17X85
1231	SO[934]	-6096.82	385.5	17X85
1232	SO[935]	-6113.82	258	17X85
1233	SO[936]	-6130.82	118	17X85
1234	SO[937]	-6147.81	385.5	17X85
1235	SO[938]	-6164.81	258	17X85
1236	SO[939]	-6181.8	118	17X85
1237	SO[940]	-6198.8	385.5	17X85
1238	SO[941]	-6215.79	258	17X85
1239	SO[942]	-6232.79	118	17X85
1240	SO[943]	-6249.78	385.5	17X85
1241	SO[944]	-6266.78	258	17X85
1242	SO[945]	-6283.77	118	17X85
1243	SO[946]	-6300.77	385.5	17X85
1244	SO[947]	-6317.76	258	17X85
1245	SO[948]	-6334.76	118	17X85
1246	SO[949]	-6351.75	385.5	17X85
1247	SO[950]	-6368.75	258	17X85
1248	SO[951]	-6385.75	118	17X85
1249	SO[952]	-6402.74	385.5	17X85
1250	SO[953]	-6419.74	258	17X85
1251	SO[954]	-6436.73	118	17X85
1252	SO[955]	-6453.73	385.5	17X85
1253	SO[956]	-6470.72	258	17X85
1254	SO[957]	-6487.72	118	17X85
1255	SO[958]	-6504.71	385.5	17X85
1256	SO[959]	-6521.71	258	17X85
1257	SO[960]	-6538.7	118	17X85
1258	SO[961]	-6555.7	385.5	17X85
1259	SO[962]	-6572.69	258	17X85
1260	SO[963]	-6589.69	118	17X85

PAD No.	PAD Name	X	Y	BUMP SIZE (um x um)
1261	SO[964]	-6606.68	385.5	17X85
1262	SO[965]	-6623.68	258	17X85
1263	SO[966]	-6640.68	118	17X85
1264	SO[967]	-6657.67	385.5	17X85
1265	SO[968]	-6674.67	258	17X85
1266	SO[969]	-6691.66	118	17X85
1267	SO[970]	-6708.66	385.5	17X85
1268	SO[971]	-6725.65	258	17X85
1269	SO[972]	-6742.65	118	17X85
1270	SO[973]	-6759.64	385.5	17X85
1271	SO[974]	-6776.64	258	17X85
1272	SO[975]	-6793.63	118	17X85
1273	SO[976]	-6810.63	385.5	17X85
1274	SO[977]	-6827.62	258	17X85
1275	SO[978]	-6844.62	118	17X85
1276	SO[979]	-6861.61	385.5	17X85
1277	SO[980]	-6878.61	258	17X85
1278	SO[981]	-6895.61	118	17X85
1279	SO[982]	-6912.6	385.5	17X85
1280	SO[983]	-6929.6	258	17X85
1281	SO[984]	-6946.59	118	17X85
1282	SO[985]	-6963.59	385.5	17X85
1283	SO[986]	-6980.58	258	17X85
1284	SO[987]	-6997.58	118	17X85
1285	SO[988]	-7014.57	385.5	17X85
1286	SO[989]	-7031.57	258	17X85
1287	SO[990]	-7048.56	118	17X85
1288	SO[991]	-7065.56	385.5	17X85
1289	SO[992]	-7082.55	258	17X85
1290	SO[993]	-7099.55	118	17X85
1291	SO[994]	-7116.54	385.5	17X85
1292	SO[995]	-7133.54	258	17X85
1293	SO[996]	-7150.54	118	17X85
1294	SO[997]	-7167.53	385.5	17X85
1295	SO[998]	-7184.53	258	17X85
1296	SO[999]	-7201.52	118	17X85
1297	SO[1000]	-7218.52	385.5	17X85
1298	SO[1001]	-7235.51	258	17X85
1299	SO[1002]	-7252.51	118	17X85
1300	SO[1003]	-7269.5	385.5	17X85
1301	SO[1004]	-7286.5	258	17X85
1302	SO[1005]	-7303.49	118	17X85
1303	SO[1006]	-7320.49	385.5	17X85
1304	SO[1007]	-7337.48	258	17X85
1305	SO[1008]	-7354.48	118	17X85

PAD No.	PAD Name	X	Y	BUMP SIZE (um x um)
1306	SO[1009]	-7371.47	385.5	17X85
1307	SO[1010]	-7388.47	258	17X85
1308	SO[1011]	-7405.46	118	17X85
1309	SO[1012]	-7422.46	385.5	17X85
1310	SO[1013]	-7439.46	258	17X85
1311	SO[1014]	-7456.45	118	17X85
1312	SO[1015]	-7473.45	385.5	17X85
1313	SO[1016]	-7490.44	258	17X85
1314	SO[1017]	-7507.44	118	17X85
1315	SO[1018]	-7524.43	385.5	17X85
1316	SO[1019]	-7541.43	258	17X85
1317	SO[1020]	-7558.42	118	17X85
1318	SO[1021]	-7575.42	385.5	17X85
1319	SO[1022]	-7592.41	258	17X85
1320	SO[1023]	-7609.41	118	17X85
1321	SO[1024]	-7626.4	385.5	17X85
1322	SO[1025]	-7643.4	258	17X85
1323	SO[1026]	-7660.39	118	17X85
1324	SO[1027]	-7677.39	385.5	17X85
1325	SO[1028]	-7694.39	258	17X85
1326	SO[1029]	-7711.38	118	17X85
1327	SO[1030]	-7728.38	385.5	17X85
1328	SO[1031]	-7745.37	258	17X85
1329	SO[1032]	-7762.37	118	17X85
1330	SO[1033]	-7779.36	385.5	17X85
1331	SO[1034]	-7796.36	258	17X85
1332	SO[1035]	-7813.35	118	17X85
1333	SO[1036]	-7830.35	385.5	17X85
1334	SO[1037]	-7847.34	258	17X85
1335	SO[1038]	-7864.34	118	17X85
1336	SO[1039]	-7881.33	385.5	17X85
1337	SO[1040]	-7898.33	258	17X85
1338	SO[1041]	-7915.32	118	17X85
1339	SO[1042]	-7932.32	385.5	17X85
1340	SO[1043]	-7949.32	258	17X85
1341	SO[1044]	-7966.31	118	17X85
1342	SO[1045]	-7983.31	385.5	17X85
1343	SO[1046]	-8000.3	258	17X85
1344	SO[1047]	-8017.3	118	17X85
1345	SO[1048]	-8034.29	385.5	17X85
1346	SO[1049]	-8051.29	258	17X85
1347	SO[1050]	-8068.28	118	17X85
1348	SO[1051]	-8085.28	385.5	17X85
1349	SO[1052]	-8102.27	258	17X85
1350	SO[1053]	-8119.27	118	17X85

PAD No.	PAD Name	X	Y	BUMP SIZE (um x um)
1351	SO[1054]	-8136.26	385.5	17X85
1352	SO[1055]	-8153.26	258	17X85
1353	SO[1056]	-8170.25	118	17X85
1354	SO[1057]	-8187.25	385.5	17X85
1355	SO[1058]	-8204.25	258	17X85
1356	SO[1059]	-8221.24	118	17X85
1357	SO[1060]	-8238.24	385.5	17X85
1358	SO[1061]	-8255.23	258	17X85
1359	SO[1062]	-8272.23	118	17X85
1360	SO[1063]	-8289.22	385.5	17X85
1361	SO[1064]	-8306.22	258	17X85
1362	SO[1065]	-8323.21	118	17X85
1363	SO[1066]	-8340.21	385.5	17X85
1364	SO[1067]	-8357.2	258	17X85
1365	SO[1068]	-8374.2	118	17X85
1366	SO[1069]	-8391.19	385.5	17X85
1367	SO[1070]	-8408.19	258	17X85
1368	SO[1071]	-8425.18	118	17X85
1369	SO[1072]	-8442.18	385.5	17X85
1370	SO[1073]	-8459.18	258	17X85
1371	SO[1074]	-8476.17	118	17X85
1372	SO[1075]	-8493.17	385.5	17X85
1373	SO[1076]	-8510.16	258	17X85
1374	SO[1077]	-8527.16	118	17X85
1375	SO[1078]	-8544.15	385.5	17X85
1376	SO[1079]	-8561.15	258	17X85
1377	SO[1080]	-8578.14	118	17X85
1378	SO[1081]	-8595.14	385.5	17X85
1379	SO[1082]	-8612.13	258	17X85
1380	SO[1083]	-8629.13	118	17X85
1381	SO[1084]	-8646.12	385.5	17X85
1382	SO[1085]	-8663.12	258	17X85
1383	SO[1086]	-8680.11	118	17X85
1384	SO[1087]	-8697.11	385.5	17X85
1385	SO[1088]	-8714.11	258	17X85
1386	SO[1089]	-8731.1	118	17X85
1387	SO[1090]	-8748.1	385.5	17X85
1388	SO[1091]	-8765.09	258	17X85
1389	SO[1092]	-8782.09	118	17X85
1390	SO[1093]	-8799.08	385.5	17X85
1391	SO[1094]	-8816.08	258	17X85
1392	SO[1095]	-8833.07	118	17X85
1393	SO[1096]	-8850.07	385.5	17X85
1394	SO[1097]	-8867.06	258	17X85
1395	SO[1098]	-8884.06	118	17X85

PAD No.	PAD Name	X	Y	BUMP SIZE (um x um)
1396	SO[1099]	-8901.05	385.5	17X85
1397	SO[1100]	-8918.05	258	17X85
1398	SO[1101]	-8935.04	118	17X85
1399	SO[1102]	-8952.04	385.5	17X85
1400	SO[1103]	-8969.04	258	17X85
1401	SO[1104]	-8986.03	118	17X85
1402	SO[1105]	-9003.03	385.5	17X85
1403	SO[1106]	-9020.02	258	17X85
1404	SO[1107]	-9037.02	118	17X85
1405	SO[1108]	-9054.01	385.5	17X85
1406	SO[1109]	-9071.01	258	17X85
1407	SO[1110]	-9088	118	17X85
1408	SO[1111]	-9105	385.5	17X85
1409	SO[1112]	-9121.99	258	17X85
1410	SO[1113]	-9138.99	118	17X85
1411	SO[1114]	-9155.98	385.5	17X85
1412	SO[1115]	-9172.98	258	17X85
1413	SO[1116]	-9189.97	118	17X85
1414	SO[1117]	-9206.97	385.5	17X85
1415	SO[1118]	-9223.97	258	17X85
1416	SO[1119]	-9240.96	118	17X85
1417	SO[1120]	-9257.96	385.5	17X85
1418	SO[1121]	-9274.95	258	17X85
1419	SO[1122]	-9291.95	118	17X85
1420	SO[1123]	-9308.94	385.5	17X85
1421	SO[1124]	-9325.94	258	17X85
1422	SO[1125]	-9342.93	118	17X85
1423	SO[1126]	-9359.93	385.5	17X85
1424	SO[1127]	-9376.92	258	17X85
1425	SO[1128]	-9393.92	118	17X85
1426	SO[1129]	-9410.91	385.5	17X85
1427	SO[1130]	-9427.91	258	17X85
1428	SO[1131]	-9444.9	118	17X85
1429	SO[1132]	-9461.9	385.5	17X85
1430	SO[1133]	-9478.9	258	17X85
1431	SO[1134]	-9495.89	118	17X85
1432	SO[1135]	-9512.89	385.5	17X85
1433	SO[1136]	-9529.88	258	17X85
1434	SO[1137]	-9546.88	118	17X85
1435	SO[1138]	-9563.87	385.5	17X85
1436	SO[1139]	-9580.87	258	17X85
1437	SO[1140]	-9597.86	118	17X85
1438	SO[1141]	-9614.86	385.5	17X85
1439	SO[1142]	-9631.85	258	17X85
1440	SO[1143]	-9648.85	118	17X85

PAD No.	PAD Name	X	Y	BUMP SIZE (um x um)
1441	SO[1144]	-9665.84	385.5	17X85
1442	SO[1145]	-9682.84	258	17X85
1443	SO[1146]	-9699.83	118	17X85
1444	SO[1147]	-9716.83	385.5	17X85
1445	SO[1148]	-9733.83	258	17X85
1446	SO[1149]	-9750.82	118	17X85
1447	SO[1150]	-9767.82	385.5	17X85
1448	SO[1151]	-9784.81	258	17X85
1449	SO[1152]	-9801.81	118	17X85
1450	SO[1153]	-9818.8	385.5	17X85
1451	SO[1154]	-9835.8	258	17X85
1452	SO[1155]	-9852.79	118	17X85
1453	SO[1156]	-9869.79	385.5	17X85
1454	SO[1157]	-9886.78	258	17X85
1455	SO[1158]	-9903.78	118	17X85
1456	SO[1159]	-9920.77	385.5	17X85
1457	SO[1160]	-9937.77	258	17X85
1458	SO[1161]	-9954.76	118	17X85
1459	SO[1162]	-9971.76	385.5	17X85
1460	SO[1163]	-9988.76	258	17X85
1461	SO[1164]	-10005.75	118	17X85
1462	SO[1165]	-10022.75	385.5	17X85
1463	SO[1166]	-10039.74	258	17X85
1464	SO[1167]	-10056.74	118	17X85
1465	SO[1168]	-10073.73	385.5	17X85
1466	SO[1169]	-10090.73	258	17X85
1467	SO[1170]	-10107.72	118	17X85
1468	SO[1171]	-10124.72	385.5	17X85
1469	SO[1172]	-10141.71	258	17X85
1470	SO[1173]	-10158.71	118	17X85
1471	SO[1174]	-10175.7	385.5	17X85
1472	SO[1175]	-10192.7	258	17X85
1473	SO[1176]	-10209.69	118	17X85
1474	SO[1177]	-10226.69	385.5	17X85
1475	SO[1178]	-10243.69	258	17X85
1476	SO[1179]	-10260.68	118	17X85
1477	SO[1180]	-10277.68	385.5	17X85
1478	SO[1181]	-10294.67	258	17X85
1479	SO[1182]	-10311.67	118	17X85
1480	SO[1183]	-10328.66	385.5	17X85
1481	SO[1184]	-10345.66	258	17X85
1482	SO[1185]	-10362.65	118	17X85
1483	SO[1186]	-10379.65	385.5	17X85
1484	SO[1187]	-10396.64	258	17X85
1485	SO[1188]	-10413.64	118	17X85

PAD No.	PAD Name	X	Y	BUMP SIZE (um x um)
1486	SO[1189]	-10430.63	385.5	17X85
1487	SO[1190]	-10447.63	258	17X85
1488	SO[1191]	-10464.62	118	17X85
1489	SO[1192]	-10481.62	385.5	17X85
1490	SO[1193]	-10498.61	258	17X85
1491	SO[1194]	-10515.61	118	17X85
1492	SO[1195]	-10532.61	385.5	17X85
1493	SO[1196]	-10549.6	258	17X85
1494	SO[1197]	-10566.6	118	17X85
1495	SO[1198]	-10583.59	385.5	17X85
1496	SO[1199]	-10600.59	258	17X85
1497	SO[1200]	-10617.58	118	17X85
1498	SHIELDING	-10661.07	405.5	30X45
1499	COM1_T	-10711.06	405.5	30X46
1500	COM1_T	-10761.04	405.5	30X47
1501	SHIELDING	-10811.03	405.5	30X48
1502	AVSS	-10861.02	405.5	30X49
1503	AVSS	-10911	405.5	30X50
1504	INVBRR	-11049	398	100X30
1505	INVBRR	-11179	398	100X30
1506	OEVR	-11049	318	100X30
1507	OEVR	-11179	318	100X30
1508	UDR	-11179	238	100X30
1509	UDR	-11049	238	100X30
1510	CKVR	-11179	158	100X30
1511	CKVR	-11049	158	100X30
1512	STV1R	-11179	78	100X30
1513	STV1R	-11049	78	100X30
1514	STV2R	-11179	-2	100X30
1515	STV2R	-11049	-2	100X30
1516	STV1R	-11179	-82	100X30
1517	STV1R	-11049	-82	100X30
1518	STBNR	-11179	-162	100X30
1519	STBNR	-11049	-162	100X30
1520	DUMR	-11179	-242	100X30
1521	DUMR	-11049	-242	100X30

8. DEFINITIONS

8.1. Data Sheet Status

Preliminary Data Sheet	This data sheet contains preliminary data; supplementary data may be published later.
Data Sheet	This data sheet contains final product specifications.

Contents in the document are subject to change without notice.

8.2. Life Support Application

These products are not designed for use in life support appliances, devices, or systems where malfunction of these products can reasonably be expected to result in personal injury. fitipower customers using or selling these products for use in such applications do so at their own risk and agree to fully indemnify fitipower for any damages resulting from such improper use or sale.

9. REVISION HISTORY

Revision	Content	Page	Date
1.0	<ol style="list-style-type: none"> 1. Change VDD operating voltage minimum value to 1.8V 2. Update chip outline dimension and pad coordinates 3. Add RSTB signal in power on/off sequence 4. Add UPDN= 'H' condition for GOSQ in pin description 5. Change the gate IC to EK73002 in application block diagram 	All 23-59 10 7,8 4	2015/06/09
1.1	Modify power on off sequence	9	2020/07/09