

Features

- Highlight
 - Outstanding anti RF, LCD and power supply interference
 - Perfect soft-touch feeling
 - Auto tuning and auto calibration
- Number of Channels
 - Up to 16x10
 - Detect up to 10 fingers
 - Scan order programmable
- Zero Additional part Count
 - Power bypass capacitor only
- Signal Processing
 - Advanced anti-interference signal processing using both hardware engine and firmware
 - Self-Calibration
 - Water and face suppression
 - Down and up scaling support to match LCD resolution
 - Support axis flipping and axis switch over for portrait and landscape modes
- Scan Speed
 - Maximum single touch up to 200Hz
 - Configurable to allow power/speed optimization
- Response times
 - Initial latency < 10ms for first touch from idle
- Sensors
 - Support single layer ITO true multi-touch mutual capacitive sensor
 - Support non-MoAlMo sensor
 - Support OGS (one glass sensor)
 - Works with PET or glass sensors, including curved profiles
 - Works with single or dual ITO layer
 - Works with all proprietary sensor patterns on the markets
 - Works with passive stylus
- Panel Thickness
 - Glass up to 2.5mm, screen size dependent
 - Plastic up to 1.2mm, screen size dependent
- Interface
 - I2C compatible slave mode 400KHz.
 - Interrupt to Host
- Power
 - Single Power supply, 2.6v~3.3v



GSL1680, 1688 Capacitive Touchscreen Controller

- I/O Interface 1.8v /3.3 compatible
- Power consumption
 - Active: <9mA, subject to configuration
 - Green: <3mA, subject to configuration
 - Sleep: <30uA
- Package
 - 40-pin QFN, 5x5 mm

Release Under NDA



Contents

Features.....	1
1. Pinout and Schematic	6
1.1. Pinout Configuration	6
1.2. Pinout Description	6
1.3. Schematic	8
2. Overview.....	8
2.1. Introduction	8
2.2. Resources	9
3. Capacitive touch Basics.....	10
3.1. Sensor and Electrode construction.....	10
3.2. Scanning Sequence	11
3.3. Touchscreen sensitivity	11
4. Detail Operation.....	12
4.1. Power Up and Reset.....	12
4.2. Calibration	12
4.3. Communication.....	13
4.3.1. Communications Protocol	13
4.3.2. I2C-compatible Addresses	13
4.3.3. Writing to the Device	13
4.3.4. Reading from the Device.....	14
4.3.5. SDA, SCL.....	14
4.3.6. IRQ.....	15



4.4.	Operation mode.....	15
4.4.1.	Shutdown mode	15
4.4.2.	Running modes.....	15
4.5.	Circuit Component.....	16
4.5.1.	Bypass Capacitors.....	16
4.5.2.	PCB Cleanliness.....	16
4.6.	Signal processing.....	16
4.6.1.	Anti-EMI interference.....	16
4.6.2.	Floating Terminal.....	16
4.6.3.	Inter Finger Interference.....	17
4.6.4.	Face and Water Suppression	17
5.	Getting Start with GSL168X.....	17
5.1.	Connection with Host.....	17
5.2.	Configuring the Device	18
5.3.	Communications With the Host.....	18
5.4.	Steps to Start GSL168X.....	18
6.	Specification	19
6.1.	Operating Conditions.....	19
6.2.	DC Specification	19
6.3.	I2C-compatible Bus Specifications.....	19
6.4.	Power Consumption	20
6.5.	Moisture Sensitivity Level	20
7.	Package.....	21
7.1.	Mechanic Dimention	21



GSL1680, 1688 Capacitive Touchscreen Controller

7.2. Marking.....	22
7.3. Part Numbers	22
8. Revision History.....	23
9. Contact.....	23

Release Under NDA

1. Pinout and Schematic

1.1. Pinout Configuration

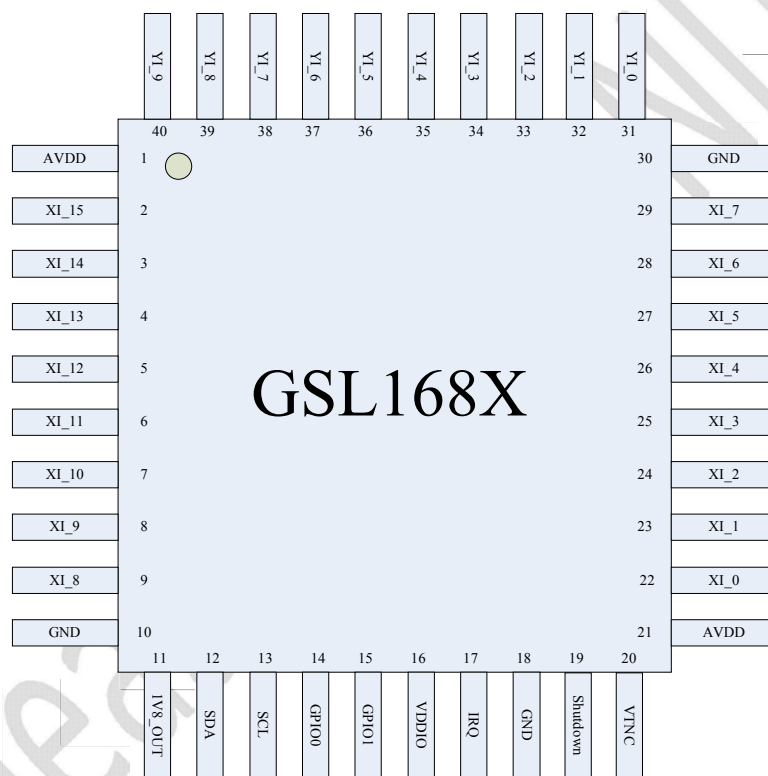

1.2. Pinout Description

	Pin Name	TYPE	Comment
1	AVDD	P	Analog power supply
2	XI_15	O	Sensor driving line
3	XI_14	O	Sensor driving line
4	XI_13	O	Sensor driving line
5	XI_12	O	Sensor driving line
6	XI_11	O	Sensor driving line



GSL1680, 1688 Capacitive Touchscreen Controller

7	XI_10	O	Sensor driving line
8	XI_9	O	Sensor driving line
9	XI_8	O	Sensor driving line
10	GND	P	Ground
11	1V8_OUT	O	Power up reset
12	SDA	I/OD	I2C data line
13	SCL	I	I2C clock line
14	GPIO0/RXD	I/O	Uart or GPIO pin
15	GPIO0/TXD	I/O	Uart or GPIO pin
16	VDDIO	P	IO Power supply
17	IRQ	O	Interrupt
18	GND	P	Ground
19	~Shutdown	I	Power down control pin
20	VTNC	O	Not connected
21	AVDD	P	Analog power supply
22	XI_0	O	Sensor driving line
23	XI_1	O	Sensor driving line
24	XI_2	O	Sensor driving line
25	XI_3	O	Sensor driving line
26	XI_4	O	Sensor driving line
27	XI_5	O	Sensor driving line
28	XI_6	O	Sensor driving line
29	XI_7	O	Sensor driving line
30	GND	P	Ground
31	YI_0	I	Sensor sensing line
32	YI_1	I	Sensor sensing line
33	YI_2	I	Sensor sensing line
34	YI_3	I	Sensor sensing line
35	YI_4	I	Sensor sensing line
36	YI_5	I	Sensor sensing line
37	YI_6	I	Sensor sensing line
38	YI_7	I	Sensor sensing line
39	YI_8	I	Sensor sensing line
40	YI_9	I	Sensor sensing line

I Input only

I/O Input and output

O Output only

OD Open drain output

P Ground or Power

1.3. Schematic

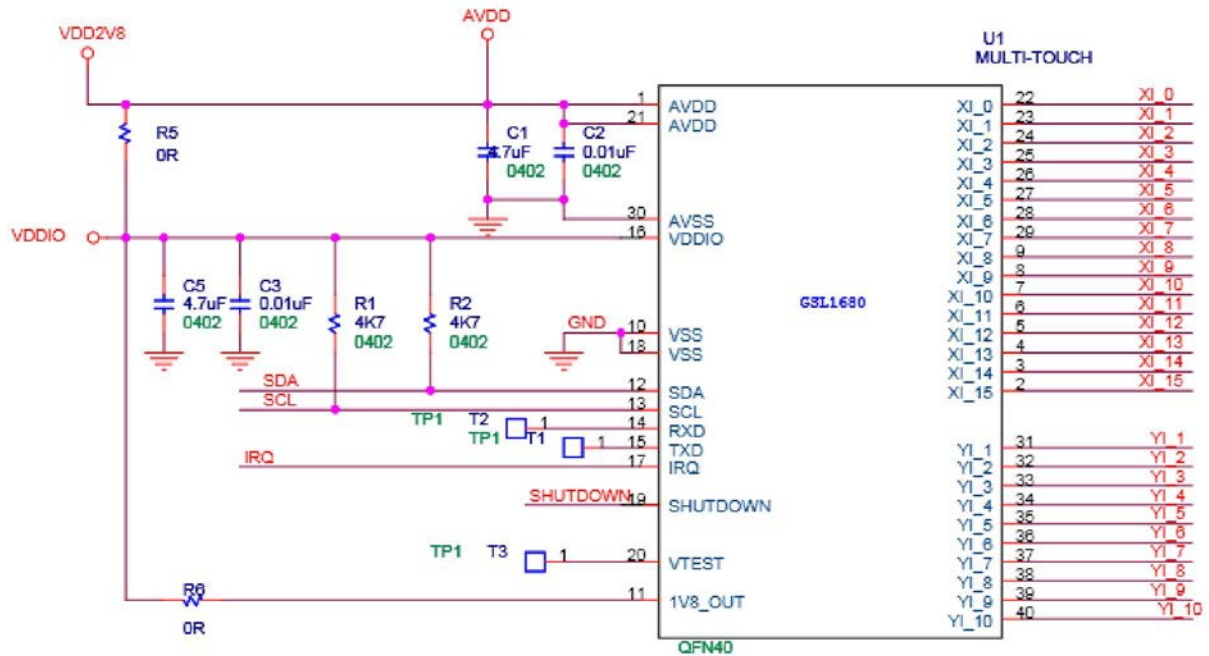

The 1V8_OUT is the 1.8v power supply from GSL168X. The GSL168X IO is 1.8v and 3.3v compatible. If the IO voltage in the system is 1.8v, R6 is needed and R5 is not needed. If the IO voltage in the system is 2.8 or 3.3v, then R5 is needed and R6 is not.

2. Overview

2.1. Introduction

The GSL168X is a highly integrated capacitive screen monolithic multi-touch controller IC.

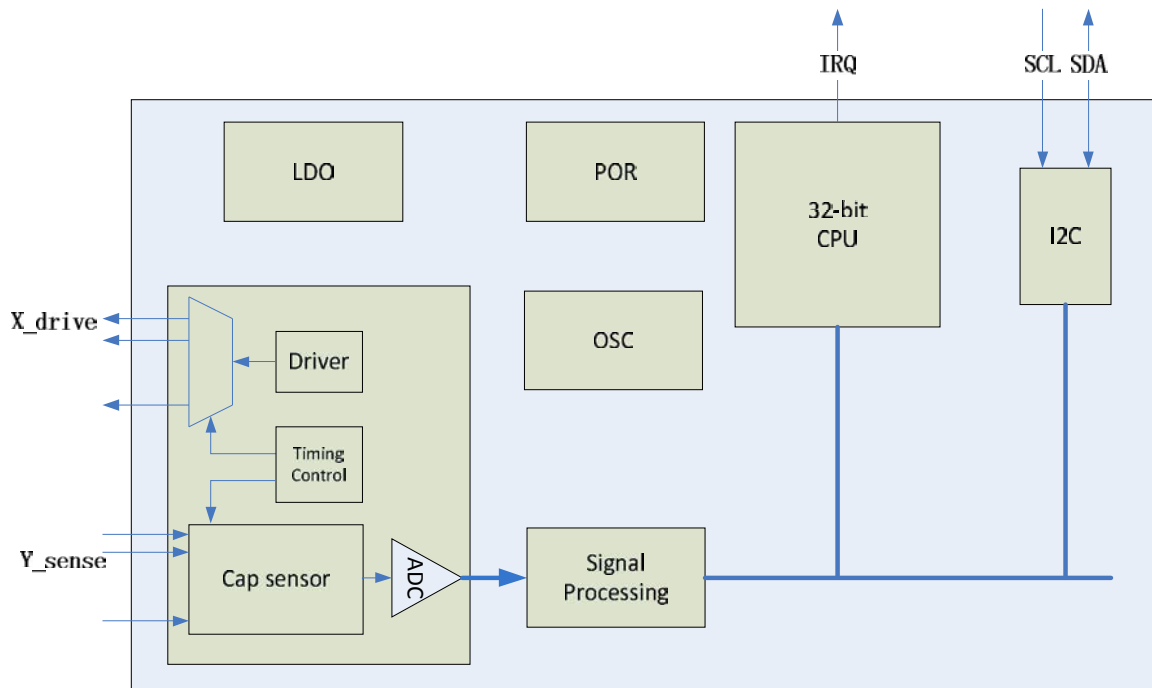

The GSL168X uses a unique mutual capacitive sensing technology. It allows the measurement of up to 192 nodes in less than 1ms. GSL168X's capacitive sensor is designed to work with a big range of sensor selections, including single or two layer sensor glass or film, strip or diamond or their varying sensor patterns, thin or thick ITO layers.

The GSL168X's sophisticated anti-EMI signal processing technology make it completely immune to all kinds of interferences including these from LCD, RF, power supply and environments. This makes GSL168X be able to adapt to all kinds of phone design.

Equipped with a powerful 32-bit RISC CPU, GSL168X can accurately estimate the weight and center of up to 10 finger touches, achieving zero-delay finger tracking with very soft-touch feeling.

The GSL168X uses a patented auto-tuning and auto-calibration technology which significantly reduced the design-in cycle and enabled a very simple host interface. What's more, the auto-track/fine tune technology used in GSL168X enable it real-time compensate the performance variance due to environment temperature and moisture changes.

2.2. Resources

The following tools are provided together with GSL168X datasheet

- [Silead Touch Testing Suite and User Guide](#)

It includes the complete production testing suite PC tools and its user guide to assist the touch panel module vendor to design and test the touch module using GSL168X.

➤ *Silead Ctouch Configure Suite and Application note*

It includes the PC tool to program the touch module and generate the configuration files to assist the touch panel module vendor and phone vendor to customize the touch panel module.

3. Capacitive touch Basics

3.1. Sensor and Electrode construction

A touchscreen is usually constructed from a number of transparent electrodes, typically on a glass or film substrate. Electrodes are normally formed by etching a material called Indium Tin Oxide (ITO) which is high optical clarity and varying sheet resistance. The ITO is etched to form X strip and Y strip shown in the following diagram. The adjacent X/Y nodes form the mutual capacitive sensors.

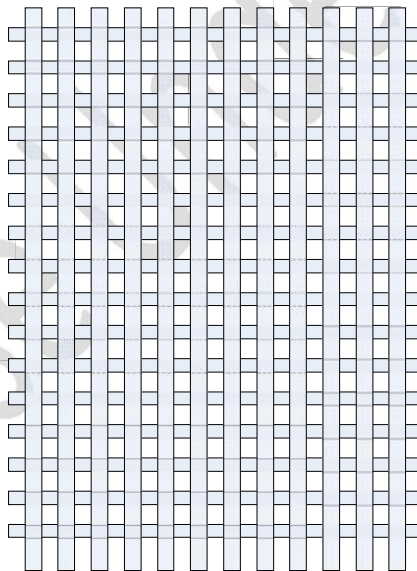

Figure

Thicker ITO yields lower levels of resistance (perhaps tens to hundreds of ohms/square) at the expense of reduced optical clarity. Lower levels of resistance are generally more compatible with capacitive sensing. Thinner ITO leads to higher levels of resistance (perhaps hundreds to thousands of ohms/square) with some of the best optical characteristics.

Long thin features, like interconnecting tracks, formed in ITO, can inhibit the capacitive sensing function due to the excessive RC time constants formed between the resistance of the track and the

capacitance of the electrode to ground. In such cases, ITO tracks should be replaced by screen printed conductive inks (non-transparent) outside of the viewing area of the touchscreen.

A range of trade-offs also exist with regard to the number of layers and different patterns used for construction. A single-layer ITO in diamond pattern or others offer a better clarity and cost performance. However, the exposure of sensing channel to LCD screen makes it vulnerable to LCD interference. A shield layer is sometimes added in the other side of the sensor glass/film to shield the LCD interference.

Two-layer designs usually offer a more favorable RC time constant and the bottom layer can shield the LCD interference in some degree if it's used as the driving channels.

GSL168X is designed to work with all the existing single or two-layer design, glass or film, diamond or strip patterns or their variance, and a wide range of RC time constant. The highly automatic tuning and calibration technology used in GSL168X reduce the effort to change sensor glass/film to the minimum.

GSL1688 is specially designed for the single layer ITO multi-touch mutual capacitive sensor. These kinds of sensor have only one layer ITO, no need of metal bridge. It significantly simplifies the mutual capacitive sensor production process. However, these sensors have a very high line resistance. The GSL1688 can support up to 150K ohm line resistance which allows the use of thin ITO layer on film whose square resistance is as big as 150 ohm.

3.2. Scanning Sequence

GSL168X supports up to 16 scanning channels and 10 sensing channels. The scanning channels are scanned in sequence. However, the scan order is fully programmable. The sensing channels are full parallelism. The channels are scanned by measuring capacitive changes at the intersections formed between X_0 and $Y_0 - Y_n$, then the intersections between X_1 and $Y_0 - Y_n$, and so on, until all X and Y combinations have been measured.

GSL168X can be configured in various ways, it is possible to disable some scanning or sensing channels so that they are not scanned at all. This can be used to improve overall scanning time. Although the sensing channels are parallel, the data order in the memory of each channel is fully programmable. This provides the maximum flexibility to the FPC or PCB design. User can program the scanning order or sensing data order through the [Silead Ctouch Configure Suite](#) or update the GSL168X configuration file directly.

3.3. Touchscreen sensitivity

Sensitivity of touchscreens can vary across the extents of the electrode pattern due to natural differences in the parasitic of the interconnections, control chip, and so on. An important factor in the

uniformity of sensitivity is the electrode design itself. It is a natural consequence of a touchscreen pattern that the edges form a discontinuity and hence tend to have a different sensitivity. The electrodes at the far edges do not have a neighboring electrode on one side and this affects the electric field distribution in that region. GSL168X auto compensate the sensitivity inconsistency for the whole touchscreen.

The mechanical stackup refers to the arrangement of material layers that exist above and below a touchscreen. The arrangement of the touchscreen in relation to other parts of the mechanical stackup has an effect on the overall sensitivity of the screen. GSL168X technology has an excellent ability to operate in the presence of ground planes close to the sensor.

Front panel dielectric material has a direct bearing on sensitivity. Plastic front panels are usually suitable up to about 1.5 mm, and glass up to about 3 mm (dependent upon the screen size and layout). The thicker the front panel, the lower the signal-to-noise ratio of the measured capacitive changes and hence the lower the resolution of the touchscreen. In general, glass front panels are near optimal because they conduct electric fields almost twice as easily film. GSL168X works well with either the glass or film front panels.

4. Detail Operation

4.1. Power Up and Reset

GSL168X takes a single power supply ranging from 2.6V~3.3V. There is an internal Power-on Reset (POR) in the device. After power-up, the device takes 5 ms before it is ready to work. In order to effect a proper POR Vdd must drop to below 1.6V.

After the chip experiences a Power-on-reset, it asserts the IRQ line to signal to the host that a message is available. The reset flag is set in the Message Processor object(refer to GSL168X Application notes for details) to indicate to the host that it has just completed a reset cycle. This bit can be used by the host to detect any unexpected power breakout events and so allow it to take any necessary corrective actions, such as reconfiguration.

A software reset command can be used to reset the chip (refer to the GSL168X Application notes). A software reset takes ~1 ms. The reset event caused by software reset or RESET pin will not trigger the Power-on-reset message to host.

4.2. Calibration

Calibration is the process by which the sensor chip assesses the background capacitance on each channel. Channels are only calibrated on power-up and when:

- the channel is held in detect for longer than the Touch Automatic Calibration setting
- the signal delta on a channel is at least the touch threshold in the anti-touch direction, while no other touches are present on the channel matrix
- the user issues a recalibrate command

4.3. Communication

4.3.1. Communications Protocol

The GSL168X uses an I2C-compatible interface for communication. The device is not designed to be polled, as it only presents data packets when internal changes have occurred. The IRQ line going active signifies that a new data packet is available.

4.3.2. I2C-compatible Addresses

The GSL168X supports a single I2C-compatible device addresses, 0x40. It is shifted left to form the SLA+W or SLA+R address when transmitted over the I2C-compatible interface, as shown in table below.

Format of SLA+W and SLA+R

Bit 7	Bit 6	Bit 5	Bit 4	Bit 3	Bit 2	Bit 1	Bit 0
Address: 0x40							Read/Write

4.3.3. Writing to the Device

A WRITE cycle to the device consists of a START condition followed by the I2C-compatible address of the device (SLA+W). The next byte is the address of the location into which the writing starts.

Subsequent bytes in a multibyte transfer – the actual data – are written to the location of the address pointer, location of the address pointer +1, location of the address pointer + 2, and so on.

The WRITE operation ends with the STOP condition on the I2C-compatible bus. A new WRITE cycle involves sending another address pointer. Note that the WRITE cycle must end with a STOP condition; the GSL168X may not respond correctly if a cycle is terminated by a new START condition.

Figure below shows an example of writing four bytes of data to contiguous addresses starting at 0x80.

Example of a Four-byte, 0x12345678 Write To Address 0x80

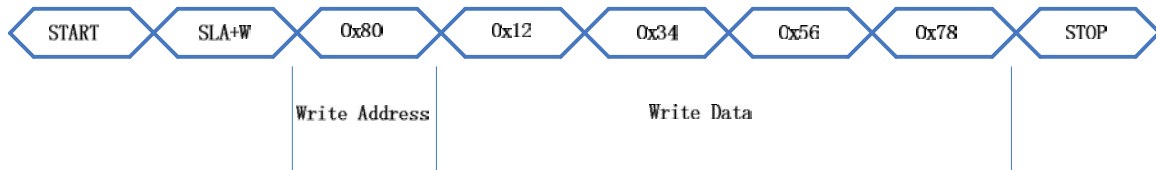

4.3.4. Reading from the Device

To read from the device, usually two I²C-compatible bus activities take place: the first is an I²C-compatible write to set the address pointer, and the second is the actual I²C-compatible read to receive the data. The address pointer returns to its starting value when the READ cycle's STOP condition is detected.

It is not necessary to set the address pointer before every read. The address pointer is updated automatically after every read operation so, if the reads occur in order, the address pointer will be correct.

The WRITE and READ cycles consist of a START condition followed by the I²C-compatible address of the device (SLA+W or SLA+R respectively). Each cycle must end with a STOP condition; the GSL168X may not respond correctly if a cycle is terminated by a new START condition.

Figure below shows the I²C-compatible commands to read four bytes from address 0x80.

Example of a Four-byte Read From Address 0x80

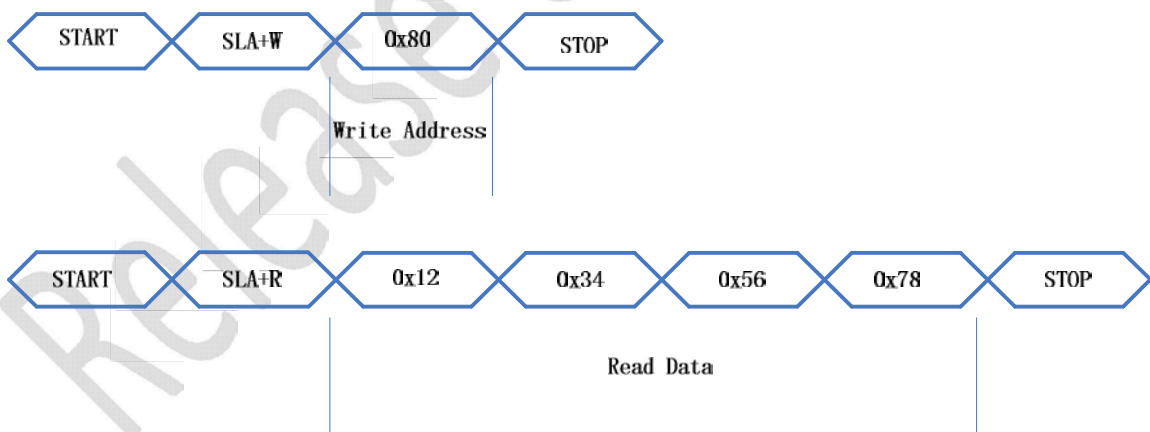

4.3.5. SDA, SCL

The I²C-compatible bus transmits data and clock with SDA and SCL, respectively. These are open-drain; that is, I²C-compatible master and slave devices can only drive these lines low or leave them open. The termination resistors (R_p) pull the line up to V_{dd} if no I²C-compatible device is pulling it down.

The termination resistors commonly range from 1 k ohm to 10 k ohm and should be chosen so that the rise times on SDA and SCL meet the I2C-compatible specifications.

4.3.6. IRQ

The IRQ pin is an active-high output pin that is used to alert the host that a new message is available. This provides the host with an interruptstyle interface with the potential for fast response times and reduces the need for wasteful I2C-compatible communications.

The host should ALWAYS use the IRQ pin as an indication that a message is available to read; the host should not read the Message at any other time (for example, continually poll the Message). As an error checking mechanism, if the chip has to read when the IRQ line is not asserted, a double read is recommended and the consistent reading results can be used as an indication that no co-occurrence of read and update of message happen.

4.4. Operation mode

The GSL168X operates at one shutdown mode and three running modes.

4.4.1. Shutdown mode

The device has a SHUTDOWN pin that, when pull low, will put GSL168X in deepsleep mode, in which the device consume the least power. After the SHUTDOWN pin is disserted, the device is wake up from the deepsleep mode and ready to take the START command from host to get into the running modes.

It is recommended to connect the SHUTDOWN pin to a GPIO of host controller. The host can put GSL168X into deepsleep mode when the touch screen is not needed to be running.

4.4.2. Running modes

When GSL168X is active, it operates on a combination of three fixed cycle times. There is one acquisition per cycle. When no channels are touched, the cycle time is given by the GREEN_SCANDELAY setting in the device configure file. Every cycle, one acquisition is made and the device then sleeps for the remainder of the cycle.

If a channel is touched, the device turn to active mode and the cycle changes to the ACTIVE_SCANDELAY setting for a faster response. It remains in this active mode until the ACTIVE_TIMEOUT has expired after the last touch, the device enters the low speed scan mode and the cycle changes to LOW_SCANDELAY setting for a slower response. If a channel is touched, the device will return to the active mode, otherwise, it stays at low speed scan mode until LOW_TIMEOUT has expired and then enter the green mode in which the device monitor the touch panel at the much slower speed.

The touch reporting rate of the active, low speed and green modes, timeout to transit from one mode to the others all are configurable through *Silead Touch Configure Suite* or GSL168X configuration file.

The default frame reporting rate of the active, low speed and green mode are, 60, 30 and 5 respectively. The maximum allowed reporting rate is 200 frames/s and the minimum allowed reporting rate is 0.5 frames/s. In each frames, multi-touch can be reported.

4.5. Circuit Component

4.5.1. Bypass Capacitors

A 100 nF and a 1 μ F ceramic bypass capacitor are highly recommended on each of Vdd and AVdd supplies (that is, 4 capacitors in total). The PCB traces connecting the capacitors to the pins of the device must not exceed 5 mm in length to limit any stray inductance that would reduce filtering effectiveness.

4.5.2. PCB Cleanliness

Modern no-clean-flux is generally compatible with capacitive sensing circuits.

If a PCB is reworked in any way, clean it thoroughly to remove all traces of the flux residue around the capacitive sensor components. Dry it thoroughly before any further testing is conducted.

4.6. Signal processing

4.6.1. Anti-EMI interference

The touch panel receives the interference from LCD, RF and power supply. Any noise may be big enough to overwhelm the useful touch information and cause false reports.

GSL168X uses patented technology to filter out these EMI interferences and recover the useful information from the corrupted signal in multiple stages. GSL168X's anti-EMI technology makes it completely immune to these EMI interferences even in a not-well designed phone.

4.6.2. Floating Terminal

If a phone or pad terminal is placed in a table instead of being held in a human hand, false signal maybe reported in these non-touched areas. This is due to the absence of the good common ground.

GSL168X is specially designed to filter out these false signals due to lack of good common ground and there is no performance degeneration when the phone/pad using GSL168X is not held in a body.

4.6.3. Inter Finger Interference

When two fingers, touching the panel, are close, it's usually difficult to separate them and two fingers may be treated as one and the wrong touch position may be reported.

GSL168X use an adjacent touch compensation technology to reduce the inter finger interference and give a accurate touching count and positions even when two finger distance are smaller than the 1.5x distance of two driving lines or sensing lines..

4.6.4. Face and Water Suppression

The GSL168X has a mechanism to suppress false detections from a touchscreen incorporated into a mobile device. For example, when water is on the touch screen, the user grips the device in their hand or, in the case of a mobile phone, holds it close to their face.

Face suppression takes both the size and shape of a touch into consideration. By considering the size of the touch, face suppression ensures that a small touch (such as from a finger) is allowed, whereas a large touch (such as from a face) is suppressed. By considering the shape of a touch – or rather the aspect ratio of a touch – face suppression ensures that a narrow shape (typically a finger) is allowed, whereas a wide shape (such as that of a face) is suppressed.

The big area Water spot in the touch panel is similar to the face touch but the shape is more random. Water suppression ensures that a small touch is allowed, whereas a large touch is suppressed. The finger touch outside of the water area is not affected.

5. Getting Start with GSL168X

5.1. Connection with Host

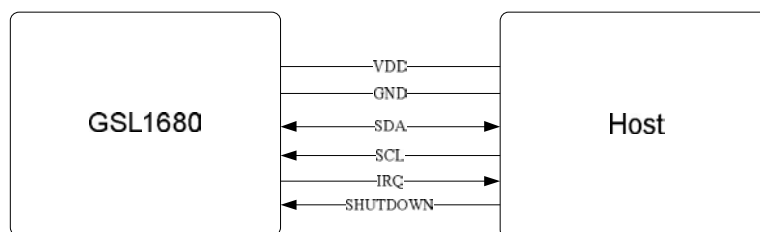

GSL168X connect to host controller through 4 pins besides the power supply. The power supply range from 2.6v to 3.6v.

SDA and SCL is the I2C compliant communication interface. Both pins are open drain. IRQ is the interrupt signal to host to indicate a new message is ready.

SHUTDOWN pin is recommended to connect to the GPIO of host. If pull the SHUTDOWN pin low by the host, the GSL168X will enter the deepsleep state to consume the least power. To wake up GSL168X from deepsleep, host has to release SHUTDOWN to high and send a START_COMMAND to GSL168X to kick it off. If SHUTDOWN feature is not needed, the pin can be leave unconnected.

5.2. Configuring the Device

GSL168X has a very high configurability. The configuration is done through the GSL168X Configuration File, which can be modified directly or be generated by the [Silead Ctouch Configure Suite](#). The Configuration File will be loaded by the GSL168X Configure API and program the device automatically when the device is initialized.

The detail can be referred to [Silead Ctouch Configure Suite](#) application notes.

5.3. Communications With the Host

GSL168X has a memory map register set to communicate with the host. These registers include the GSL168X event message, touch information, and the command queue to accept host instruction. A predefined API (refer to GSL168X Application Notes) example is provided together with GSL168X to assist communications.

5.4. Steps to Start GSL168X

When power up, IRQ line will go low and the interrupt message in the memory mapped register show it's a power up interrupt. The host driver will then start the GSL168X initialization in which the GSL168X configurable File is loaded to program the device.

Once the configurable is finished, host will start the GSL168X. GSL168X will go through the calibration cycle and enter green mode and start monitoring the touch screen. If a touch is detected, GSL168X will transit to active mode and IRQ will go high and interrupt host to report a touch event.

6. Specification

6.1. Operating Conditions

Parameter	Min	Typ	Max
AVDD	2.6v	2.8v	3.3v
Supply ripple + noise			300mV
Operating temp	-20°C	+25°C	+85°C

6.2. DC Specification

Parameter	Description	Min	Typ	Max	Unit	Note
I _{dd}	Average supply current, 60Hz, 1 touch		8mA			
V _{il}	Low Input Logic Level	-0.5		0.3 V _{dd}	V	
V _{ih}	High Input Logic Level	0.7 V _{dd}		V _{dd} +0.5	V	
V _{ol}	Low output voltage		0.2V _{dd}			
V _{oh}	High output voltage	0.8V _{dd}			V	
I _{il}	Input leakage current		<0.001	1	uA	

6.3. I2C-compatible Bus Specifications

Parameter	Operation
Address	0X40
Maximum bus speed (SCL)	400KHz
Hold time START condition	<650 ns
Setup time for STOP condition	<650 ns
SDA/SCL/ rise time	< 200 ns

6.4. Power Consumption

Parameter	Operation	Note
SHUTDOWN Mode	<30uA	
Green Mode	<3mA	5 frame/s, charge time 5us
Low Scan Speed	< 6mA	30 frame/s, charge time 5us
Active Mode	<9 mA	60 frame/s, charge time 5us

6.5. Moisture Sensitivity Level

MSL Rating	Peak Body Temperature	Specification
MSL3	260°C	IPC/JEDEC-STD-020

7. Package

7.1. Mechanic Dimention

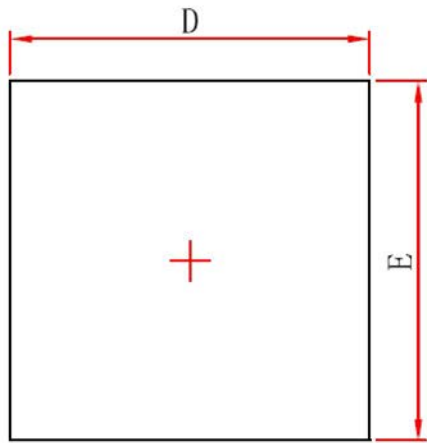

Top View

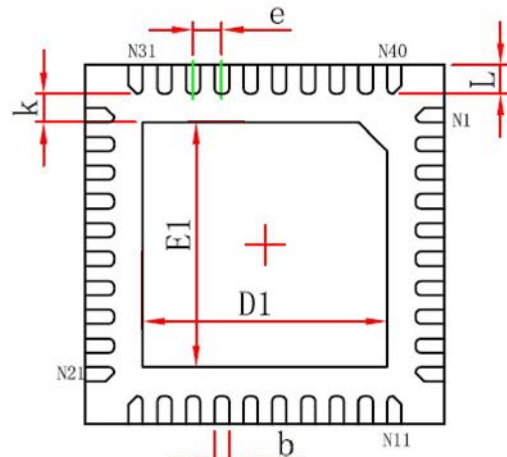

Bottom View

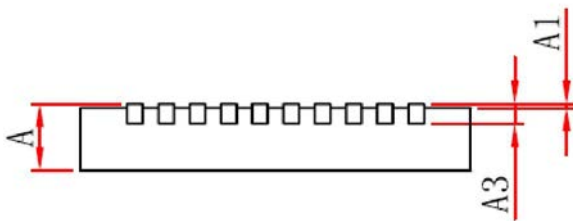

Side View



GSL1680, 1688 Capacitive Touchscreen Controller

Symbol	Dimensions In Millimeters		Dimensions In Inches	
	Min.	Max.	Min.	Max.
A	0.700/0.800	0.800/0.900	0.028/0.031	0.031/0.035
A1	0.000	0.050	0.000	0.002
A3	0.203REF.		0.008REF.	
D	4.924	5.076	0.194	0.200
E	4.924	5.076	0.194	0.200
D1	3.300	3.500	0.130	0.138
E1	3.300	3.500	0.130	0.138
k	0.200MIN.		0.008MIN.	
b	0.150	0.250	0.006	0.010
e	0.400TYP.		0.016TYP.	
L	0.324	0.476	0.013	0.019

7.2. Marking

7.3. Part Numbers

Part Number	Description
GSL168XQ40	40-pin 5x5 mm QFN RoHS compliant



8. Revision History

Revision Number	History
Revision A1.0 – Nov 2011	Initial release
Revision A1.6 – Oct 2012	Add GSL1688

9. Contact

上海浦东新区盛夏路 560 号 2 幢 1003 思立微电子 201203

Tel: 021-20221991 Fax: 021-20221996

Email: minor_deng@sileadinc.com