



ST72568

1200CH System-On-Chip Driver for 800RGBx480 TFT LCD

Datasheet

Sitronix reserves the right to change the contents in this document without prior notice, please contact Sitronix to obtain the latest version of datasheet before placing your order. No responsibility is assumed by Sitronix for any infringement of patent or other rights of third parties which may result from its use.

© 2022 Sitronix Technology Corporation. All rights reserved.

V1.0

2022/9

Hazardous Substance Free

RoHS/ REACH Compliant

Sitronix Technology Corporation

Sitronix Technology Corp. reserves the right to change the contents in this document without prior notice.

LIST OF CONTENT

1. GENERAL DESCRIPTION	5
2. FEATURES	6
3. PAD ARRANGEMENT	7
3.1 Output Bump Dimension	7
3.2 Bump Dimension.....	8
3.3 Alignment Mark Dimension	8
4. PAD CENTER COORDINATES	9
5. BLOCK DIAGRAM	40
6. PIN DESCRIPTION	41
6.1 Pin Function	41
7. COMMUNICATION INTERFACE	45
7.1 3-wire Serial Interface.....	45
7.2 RGB Interface	46
7.2.1 SYNC Mode.....	46
7.2.2 SYNC-DE Mode.....	47
7.2.3 DE Mode.....	48
7.2.4 Parallel 24-bit RGB Input Timing Table	49
7.3 LVDS Interface.....	50
7.3.1 LVDS Input Pin Mapping Table.....	50
7.3.2 4 Lane VESA Data Format Color Bit Map	50
7.3.3 4 Lane JEIDA Data Format Color Bit Map.....	50
7.3.4 3 Lane VESA Mode Color Bit Map.....	51
7.3.5 3 Lane JEIDA Mode Color Bit Map	51
7.3.6 LVDS Input Timing Table.....	51
8. REGISTER LIST.....	53
8.1 Register Summary	53
8.2 Command Table1 Register Description	56
8.2.1 GRB · DISP CONTROL (10h)	56
8.2.2 CONTRAST (11h)	56
8.2.3 SUB_CONTRAST_R (12h).....	56
8.2.4 SUB_CONTRAST_B (13h).....	57
8.2.5 BRIGHTNESS (14h).....	57
8.2.6 SUB-BRIGHTNESS_R (15h).....	57
8.2.7 SUB-BRIGHTNESS_B (16h).....	58
8.2.8 H_BLANKING (17h)	58
8.2.9 V_BLANKING (18h).....	58
8.2.10 OTP AUTO DOWNLOAD CONTROL (1Ch).....	58
8.3 Command Table2 Register Description	59

8.3.1 GVDD SETTING (40h)	59
8.3.2 GVCL SETTING (41h).....	60
8.3.3 VGHS, VGL SETTING (45h).....	61
8.4 Gamma Table Register Description	62
8.4.1 GAMMA SETTING (20h~29h, 30h~39h).....	62
8.5 OTP Table Register Description	64
8.5.1 ID1 SETTING (01h).....	64
8.5.2 ID2 SETTING (02h).....	64
8.5.3 ID3 SETTING (03h).....	64
8.5.4 VCOM OFFSET SETTING (05h)	64
8.5.5 OTP FUNCTION CONTROL (60h)	65
8.5.6 OTP ACKNOWLEDGEMENT CONTROL (65h).....	65
8.5.7 ID1 PROGRAM TIMES (68h)	66
8.5.8 ID2 PROGRAM TIMES (69h)	66
8.5.9 ID3 PROGRAM TIMES (6Ah).....	66
8.5.10 VCOM OFFEST PROGRAM TIMES (6Ch)	66
9. ELECTRICAL SPECIFICATIONS	67
9.1 Absolute Maximum Ratings.....	67
9.2 DC Characteristics	68
9.2.1 Recommended Operating Range	68
9.2.2 DC Characteristics for Digital Circuit	68
9.2.3 DC Characteristics for Analog Circuit.....	68
9.2.4 DC Characteristics for LVDS Receiver Circuit.....	69
9.3 AC Characteristics	70
9.3.1 System Operation AC Characteristics	70
9.3.2 System Bus Timing for 3-Wire SPI Interface	70
9.3.3 System Bus Timing for RGB Interface	71
9.3.4 Reset timing.....	73
10. APPLICATION CIRCUIT	74
10.1 1 Power Mode	74
10.1.1 Input Voltage.....	75
10.1.2 External component.....	75
10.2 3 Power Mode with Charge Pump Controller	76
10.2.1 Input Voltage.....	77
10.2.2 External component.....	77
10.3 3 Power Mode with External Power Supply.....	78
10.3.1 Input Voltage.....	79
10.3.2 External component.....	79
10.4 Input Color Format Application Circuit	80
10.4.1 Pin Assignment for RGB Interface	80

10.4.2 Data Format	81
10.4.3 16.7M (R G B, 8 8 8) INPUT COLOR FORMAT	84
10.4.4 262K (R G B, 6 6 6) INPUT COLOR FORMAT	84
10.4.5 65K (R G B, 5 6 5) INPUT COLOR FORMAT	84
11. POWER ON/OFF SEQUENCE	85
11.1 Power On Sequence	85
11.1.1 1 Power Mode	85
11.1.2 3 Power Mode with Charge Pump Controller.....	86
11.1.3 3 Power Mode with External Power Supply.....	87
11.2 Power Off Sequence	88
11.2.1 1 Power Mode	88
11.2.2 3 Power Mode with Charge Pump Controller.....	89
11.2.3 3 Power Mode with External Power Supply.....	90
12. RECOMMENDED PANEL ROUTING RESISTANCE	91
13. COLOR FILTER ARRANGEMENT	92
14. REVISION HISTORY	93

1. GENERAL DESCRIPTION

IC offers all-in-one chip solution of 800RGBx480 for color dual gate TFT-LCD panel. The driver IC output ports consists of 1200 source channels and 24 gate control channels for panel application. This chip incorporated with digital timing generator, source and gate driver, power supply circuit and embedded 3-wire SPI interfaces for function setting. The display data bits sent from MCU via LVDS interface or RGB interface directly related to the pixels of LCD panel. The source output supports 256 gray scale with real 8-bit DAC to get a small output deviation for high color resolution. The power supply circuit incorporated with step-up circuit, regulators and operational amplifiers to generate power supply voltages to drive TFT LCD.

2. FEATURES

- Display Resolution: arbitrary resolution up to 800*RGB (H) * 480(V)
 - 256 Gray Scale with True 8-bit DAC
 - full color mode: 16.7M colors (25-bit 8(R):8(G):8(B))
- LCD Driver Output Circuits
 - source outputs: 1200channels
 - gate outputs: 24 GIP control signals
 - common electrode output
- Display Data Interface
 - 3 lane and 4 lane LVDS interface
 - 24-bit RGB interface support: SYNC, SYNC-DE and DE mode
- Register Setting Interface
 - 3-wire SPI interface
- On Chip Build-In Circuits
 - DC/DC converter
 - Multi-OTP circuit
 - Timing controller
- Wide Supply Voltage Range
 - I/O voltage (VDDI to DGND): 3.1V~3.6V
 - analog voltage (VDD to AGND): 3.1V ~3.6V
 - charge pump voltage (PVDD to PGND): 3.1V ~3.6V
- On-Chip Power System
 - GVDD: 4.6125V ~ 6.0V
 - GVCL: -3.0125V ~ -4.40V
 - VCOM: GND (Including built-in circuit for compensating feed-through voltage)
 - Maximum Vop : $Vop(Max.) \leq GVDD-VCOM = VCOM - GVCL$
- Optimized Layout for COG Assembly
- Support 1 Power Mode and 3 Power Mode
- Built-in Multi-OTP Programming Circuit
 - Internal VPP power supply
- Multi-OTP Adjustable Parameters
 - 7-bit for VCOM offset adjustment
 - 7-bit ID1/ID2/ID3 OTP for end user use
- Temperature Range: -30°C ~ 85°C
- GAS function for preventing image sticking when abnormal power off
- Design for industrial applications; this product is not designed for use in military equipment, marine equipment, aircraft equipment and other applications in extreme environment

3. PAD ARRANGEMENT

3.1 Output Bump Dimension

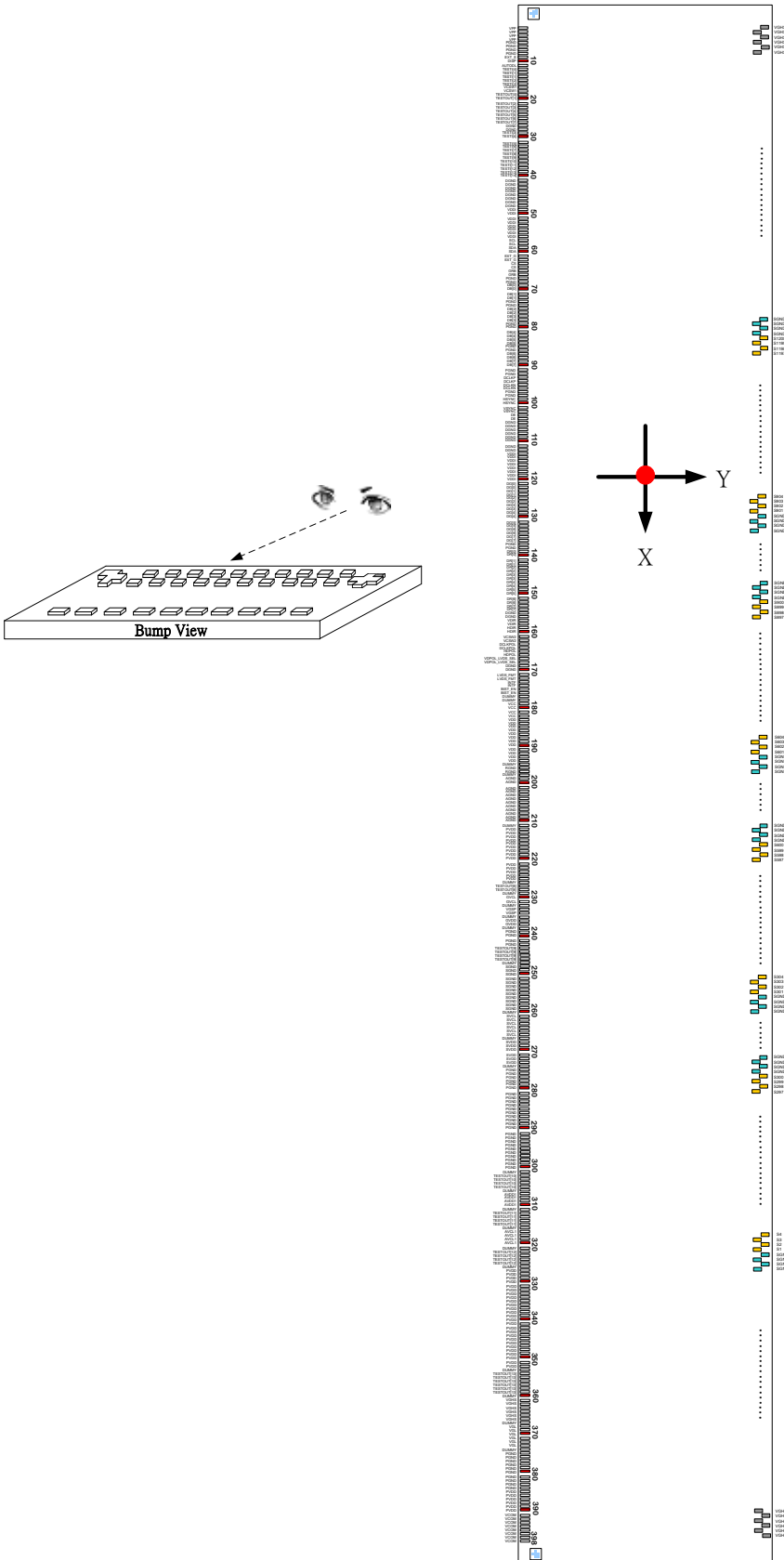

3.2 Bump Dimension

(Pad NO. 399~1990)

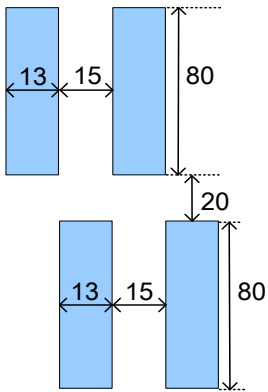

(Pad NO. 1~398)

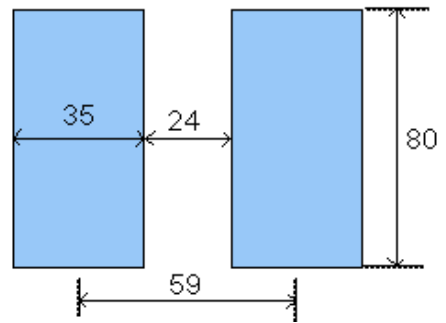

3.3 Alignment Mark Dimension

Alignment Mark: A1(X,Y)=(-11812,-337)

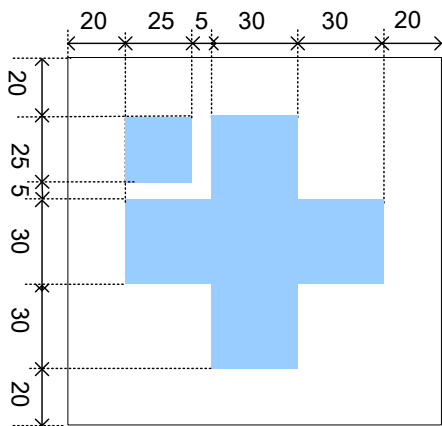

Alignment Mark: A2(X,Y)=(11812,-337)

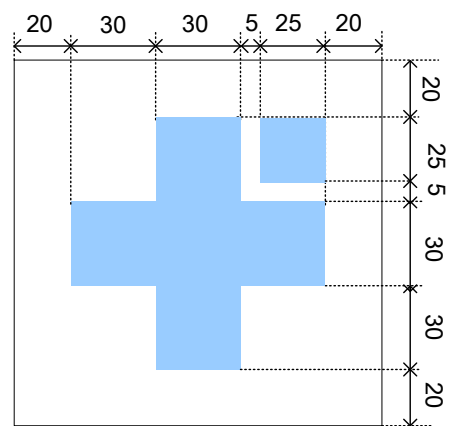

4. PAD CENTER COORDINATES

PAD No.	PIN Name	X	Y	PAD No.	PIN Name	X	Y
1	VPP	-11712	-347.5	34	TESTI[8]	-9765	-347.5
2	VPP	-11653	-347.5	35	TESTI[9]	-9706	-347.5
3	VPP	-11594	-347.5	36	TESTI[10]	-9647	-347.5
4	VPP	-11535	-347.5	37	TESTI[11]	-9588	-347.5
5	PGND	-11476	-347.5	38	TESTI[12]	-9529	-347.5
6	PGND	-11417	-347.5	39	TESTI[13]	-9470	-347.5
7	PGND	-11358	-347.5	40	TESTI[14]	-9411	-347.5
8	PGND	-11299	-347.5	41	DGND	-9352	-347.5
9	EXT_S	-11240	-347.5	42	DGND	-9293	-347.5
10	DISP	-11181	-347.5	43	DGND	-9234	-347.5
11	AUTODL	-11122	-347.5	44	DGND	-9175	-347.5
12	TESTI[0]	-11063	-347.5	45	DGND	-9116	-347.5
13	TESTI[1]	-11004	-347.5	46	DGND	-9057	-347.5
14	TESTI[1]	-10945	-347.5	47	DGND	-8998	-347.5
15	TESTI[2]	-10886	-347.5	48	DGND	-8939	-347.5
16	TESTI[2]	-10827	-347.5	49	VDDI	-8880	-347.5
17	VCSW1	-10768	-347.5	50	VDDI	-8821	-347.5
18	VCSW1	-10709	-347.5	51	VDDI	-8762	-347.5
19	TESTOUT[0]	-10650	-347.5	52	VDDI	-8703	-347.5
20	TESTOUT[1]	-10591	-347.5	53	VDDI	-8644	-347.5
21	TESTOUT[2]	-10532	-347.5	54	VDDI	-8585	-347.5
22	TESTOUT[3]	-10473	-347.5	55	VDDI	-8526	-347.5
23	TESTOUT[4]	-10414	-347.5	56	VDDI	-8467	-347.5
24	TESTOUT[5]	-10355	-347.5	57	SCL	-8408	-347.5
25	TESTOUT[6]	-10296	-347.5	58	SCL	-8349	-347.5
26	TESTOUT[7]	-10237	-347.5	59	SDA	-8290	-347.5
27	DGND	-10178	-347.5	60	SDA	-8231	-347.5
28	DGND	-10119	-347.5	61	EXT_G	-8172	-347.5
29	TESTI[3]	-10060	-347.5	62	EXT_G	-8113	-347.5
30	TESTI[4]	-10001	-347.5	63	CS	-8054	-347.5
31	TESTI[5]	-9942	-347.5	64	CS	-7995	-347.5
32	TESTI[6]	-9883	-347.5	65	GRB	-7936	-347.5
33	TESTI[7]	-9824	-347.5	66	GRB	-7877	-347.5

PAD No.	PIN Name	X	Y	PAD No.	PIN Name	X	Y
67	PGND	-7818	-347.5	100	HSYNC	-5871	-347.5
68	PGND	-7759	-347.5	101	VSYNC	-5812	-347.5
69	DB[0]	-7700	-347.5	102	VSYNC	-5753	-347.5
70	DB[0]	-7641	-347.5	103	DE	-5694	-347.5
71	DB[1]	-7582	-347.5	104	DE	-5635	-347.5
72	DB[1]	-7523	-347.5	105	DGND	-5576	-347.5
73	PGND	-7464	-347.5	106	DGND	-5517	-347.5
74	PGND	-7405	-347.5	107	DGND	-5458	-347.5
75	DB[2]	-7346	-347.5	108	DGND	-5399	-347.5
76	DB[2]	-7287	-347.5	109	DGND	-5340	-347.5
77	DB[3]	-7228	-347.5	110	DGND	-5281	-347.5
78	DB[3]	-7169	-347.5	111	DGND	-5222	-347.5
79	PGND	-7110	-347.5	112	DGND	-5163	-347.5
80	PGND	-7051	-347.5	113	VDDI	-5104	-347.5
81	DB[4]	-6992	-347.5	114	VDDI	-5045	-347.5
82	DB[4]	-6933	-347.5	115	VDDI	-4986	-347.5
83	DB[5]	-6874	-347.5	116	VDDI	-4927	-347.5
84	DB[5]	-6815	-347.5	117	VDDI	-4868	-347.5
85	PGND	-6756	-347.5	118	VDDI	-4809	-347.5
86	PGND	-6697	-347.5	119	VDDI	-4750	-347.5
87	DB[6]	-6638	-347.5	120	VDDI	-4691	-347.5
88	DB[6]	-6579	-347.5	121	DG[0]	-4632	-347.5
89	DB[7]	-6520	-347.5	122	DG[0]	-4573	-347.5
90	DB[7]	-6461	-347.5	123	DG[1]	-4514	-347.5
91	PGND	-6402	-347.5	124	DG[1]	-4455	-347.5
92	PGND	-6343	-347.5	125	DG[2]	-4396	-347.5
93	DCLKP	-6284	-347.5	126	DG[2]	-4337	-347.5
94	DCLKP	-6225	-347.5	127	DG[3]	-4278	-347.5
95	DCLKN	-6166	-347.5	128	DG[3]	-4219	-347.5
96	DCLKN	-6107	-347.5	129	DG[4]	-4160	-347.5
97	PGND	-6048	-347.5	130	DG[4]	-4101	-347.5
98	PGND	-5989	-347.5	131	DG[5]	-4042	-347.5
99	HSYNC	-5930	-347.5	132	DG[5]	-3983	-347.5

PAD No.	PIN Name	X	Y	PAD No.	PIN Name	X	Y
133	DG[6]	-3924	-347.5	166	HDPOL	-1977	-347.5
134	DG[6]	-3865	-347.5	167	VDPOL_LVDS_SEL	-1918	-347.5
135	DG[7]	-3806	-347.5	168	VDPOL_LVDS_SEL	-1859	-347.5
136	DG[7]	-3747	-347.5	169	DGND	-1800	-347.5
137	PGND	-3688	-347.5	170	DGND	-1741	-347.5
138	PGND	-3629	-347.5	171	LVDS_FMT	-1682	-347.5
139	DR[0]	-3570	-347.5	172	LVDS_FMT	-1623	-347.5
140	DR[0]	-3511	-347.5	173	INTF	-1564	-347.5
141	DR[1]	-3452	-347.5	174	INTF	-1505	-347.5
142	DR[1]	-3393	-347.5	175	BIST_EN	-1446	-347.5
143	DR[2]	-3334	-347.5	176	BIST_EN	-1387	-347.5
144	DR[2]	-3275	-347.5	177	DUMMY	-1328	-347.5
145	DR[3]	-3216	-347.5	178	DUMMY	-1269	-347.5
146	DR[3]	-3157	-347.5	179	VCC	-1210	-347.5
147	DR[4]	-3098	-347.5	180	VCC	-1151	-347.5
148	DR[4]	-3039	-347.5	181	VCC	-1092	-347.5
149	DR[5]	-2980	-347.5	182	VCC	-1033	-347.5
150	DR[5]	-2921	-347.5	183	VDD	-974	-347.5
151	DR[6]	-2862	-347.5	184	VDD	-915	-347.5
152	DR[6]	-2803	-347.5	185	VDD	-856	-347.5
153	DR[7]	-2744	-347.5	186	VDD	-797	-347.5
154	DR[7]	-2685	-347.5	187	VDD	-738	-347.5
155	DGND	-2626	-347.5	188	VDD	-679	-347.5
156	DGND	-2567	-347.5	189	VDD	-620	-347.5
157	VDIR	-2508	-347.5	190	VDD	-561	-347.5
158	VDIR	-2449	-347.5	191	VDD	-502	-347.5
159	HDIR	-2390	-347.5	192	VDD	-443	-347.5
160	HDIR	-2331	-347.5	193	VDD	-384	-347.5
161	VCSW2	-2272	-347.5	194	VDD	-325	-347.5
162	VCSW2	-2213	-347.5	195	DUMMY	-266	-347.5
163	DCLKPOL	-2154	-347.5	196	RGND	-207	-347.5
164	DCLKPOL	-2095	-347.5	197	RGND	-148	-347.5
165	HDPOL	-2036	-347.5	198	DUMMY	-89	-347.5

PAD No.	PIN Name	X	Y	PAD No.	PIN Name	X	Y
199	AGND	-30	-347.5	232	DUMMY	1918	-347.5
200	AGND	30	-347.5	233	VGSP	1977	-347.5
201	AGND	89	-347.5	234	VGSP	2036	-347.5
202	AGND	148	-347.5	235	DUMMY	2095	-347.5
203	AGND	207	-347.5	236	GVDD	2154	-347.5
204	AGND	266	-347.5	237	GVDD	2213	-347.5
205	AGND	325	-347.5	238	DUMMY	2272	-347.5
206	AGND	384	-347.5	239	PGND	2331	-347.5
207	AGND	443	-347.5	240	PGND	2390	-347.5
208	AGND	502	-347.5	241	PGND	2449	-347.5
209	AGND	561	-347.5	242	PGND	2508	-347.5
210	AGND	620	-347.5	243	TESTOUT[9]	2567	-347.5
211	DUMMY	679	-347.5	244	TESTOUT[9]	2626	-347.5
212	PVDD	738	-347.5	245	TESTOUT[9]	2685	-347.5
213	PVDD	797	-347.5	246	TESTOUT[9]	2744	-347.5
214	PVDD	856	-347.5	247	DUMMY	2803	-347.5
215	PVDD	915	-347.5	248	SGND	2862	-347.5
216	PVDD	974	-347.5	249	SGND	2921	-347.5
217	PVDD	1033	-347.5	250	SGND	2980	-347.5
218	PVDD	1092	-347.5	251	SGND	3039	-347.5
219	PVDD	1151	-347.5	252	SGND	3098	-347.5
220	PVDD	1210	-347.5	253	SGND	3157	-347.5
221	PVDD	1269	-347.5	254	SGND	3216	-347.5
222	PVDD	1328	-347.5	255	SGND	3275	-347.5
223	PVDD	1387	-347.5	256	SGND	3334	-347.5
224	PVDD	1446	-347.5	257	SGND	3393	-347.5
225	PVDD	1505	-347.5	258	SGND	3452	-347.5
226	DUMMY	1564	-347.5	259	SGND	3511	-347.5
227	TESTOUT[8]	1623	-347.5	260	DUMMY	3570	-347.5
228	TESTOUT[8]	1682	-347.5	261	SVCL	3629	-347.5
229	DUMMY	1741	-347.5	262	SVCL	3688	-347.5
230	GVCL	1800	-347.5	263	SVCL	3747	-347.5
231	GVCL	1859	-347.5	264	SVCL	3806	-347.5

PAD No.	PIN Name	X	Y
265	SVCL	3865	-347.5
266	SVCL	3924	-347.5
267	DUMMY	3983	-347.5
268	SVDD	4042	-347.5
269	SVDD	4101	-347.5
270	SVDD	4160	-347.5
271	SVDD	4219	-347.5
272	SVDD	4278	-347.5
273	SVDD	4337	-347.5
274	DUMMY	4396	-347.5
275	PGND	4455	-347.5
276	PGND	4514	-347.5
277	PGND	4573	-347.5
278	PGND	4632	-347.5
279	PGND	4691	-347.5
280	PGND	4750	-347.5
281	PGND	4809	-347.5
282	PGND	4868	-347.5
283	PGND	4927	-347.5
284	PGND	4986	-347.5
285	PGND	5045	-347.5
286	PGND	5104	-347.5
287	PGND	5163	-347.5
288	PGND	5222	-347.5
289	PGND	5281	-347.5
290	PGND	5340	-347.5
291	PGND	5399	-347.5
292	PGND	5458	-347.5
293	PGND	5517	-347.5
294	PGND	5576	-347.5
295	PGND	5635	-347.5
296	PGND	5694	-347.5
297	PGND	5753	-347.5

PAD No.	PIN Name	X	Y
298	PGND	5812	-347.5
299	PGND	5871	-347.5
300	PGND	5930	-347.5
301	DUMMY	5989	-347.5
302	TESTOUT[10]	6048	-347.5
303	TESTOUT[10]	6107	-347.5
304	TESTOUT[10]	6166	-347.5
305	TESTOUT[10]	6225	-347.5
306	DUMMY	6284	-347.5
307	AVDD1	6343	-347.5
308	AVDD1	6402	-347.5
309	AVDD1	6461	-347.5
310	AVDD1	6520	-347.5
311	DUMMY	6579	-347.5
312	TESTOUT[11]	6638	-347.5
313	TESTOUT[11]	6697	-347.5
314	TESTOUT[11]	6756	-347.5
315	TESTOUT[11]	6815	-347.5
316	DUMMY	6874	-347.5
317	AVCL1	6933	-347.5
318	AVCL1	6992	-347.5
319	AVCL1	7051	-347.5
320	AVCL1	7110	-347.5
321	DUMMY	7169	-347.5
322	TESTOUT[12]	7228	-347.5
323	TESTOUT[12]	7287	-347.5
324	TESTOUT[12]	7346	-347.5
325	TESTOUT[12]	7405	-347.5
326	DUMMY	7464	-347.5
327	PVDD	7523	-347.5
328	PVDD	7582	-347.5
329	PVDD	7641	-347.5
330	PVDD	7700	-347.5

PAD No.	PIN Name	X	Y
331	PVDD	7759	-347.5
332	PVDD	7818	-347.5
333	PVDD	7877	-347.5
334	PVDD	7936	-347.5
335	PVDD	7995	-347.5
336	PVDD	8054	-347.5
337	PVDD	8113	-347.5
338	PVDD	8172	-347.5
339	PVDD	8231	-347.5
340	PVDD	8290	-347.5
341	PVDD	8349	-347.5
342	PVDD	8408	-347.5
343	PVDD	8467	-347.5
344	PVDD	8526	-347.5
345	PVDD	8585	-347.5
346	PVDD	8644	-347.5
347	PVDD	8703	-347.5
348	PVDD	8762	-347.5
349	PVDD	8821	-347.5
350	PVDD	8880	-347.5
351	PVDD	8939	-347.5
352	PVDD	8998	-347.5
353	DUMMY	9057	-347.5
354	TESTOUT[13]	9116	-347.5
355	TESTOUT[13]	9175	-347.5
356	TESTOUT[13]	9234	-347.5
357	TESTOUT[13]	9293	-347.5
358	TESTOUT[13]	9352	-347.5
359	TESTOUT[13]	9411	-347.5
360	DUMMY	9470	-347.5
361	VGHS	9529	-347.5
362	VGHS	9588	-347.5
363	VGHS	9647	-347.5

PAD No.	PIN Name	X	Y
364	VGHS	9706	-347.5
365	VGHS	9765	-347.5
366	VGHS	9824	-347.5
367	DUMMY	9883	-347.5
368	VGL	9942	-347.5
369	VGL	10001	-347.5
370	VGL	10060	-347.5
371	VGL	10119	-347.5
372	VGL	10178	-347.5
373	VGL	10237	-347.5
374	DUMMY	10296	-347.5
375	PGND	10355	-347.5
376	PGND	10414	-347.5
377	PGND	10473	-347.5
378	PGND	10532	-347.5
379	PGND	10591	-347.5
380	PGND	10650	-347.5
381	PGND	10709	-347.5
382	PGND	10768	-347.5
383	PGND	10827	-347.5
384	PGND	10886	-347.5
385	PVDD	10945	-347.5
386	PVDD	11004	-347.5
387	PVDD	11063	-347.5
388	PVDD	11122	-347.5
389	PVDD	11181	-347.5
390	PVDD	11240	-347.5
391	VCOM	11299	-347.5
392	VCOM	11358	-347.5
393	VCOM	11417	-347.5
394	VCOM	11476	-347.5
395	VCOM	11535	-347.5
396	VCOM	11594	-347.5

PAD No.	PIN Name	X	Y
397	VCOM	11653	-347.5
398	VCOM	11712	-347.5
399	VGHS	11606	337.5
400	VGHS	11592	222.5
401	VGHS	11578	337.5
402	VGHS	11564	222.5
403	VGHS	11550	337.5
404	VGHS	11536	222.5
405	GOR[11]	11522	337.5
406	GOR[11]	11508	222.5
407	GOR[11]	11494	337.5
408	GOR[12]	11480	222.5
409	GOR[12]	11466	337.5
410	GOR[12]	11452	222.5
411	GOR[1]	11382	337.5
412	GOR[1]	11368	222.5
413	GOR[1]	11354	337.5
414	GOR[2]	11340	222.5
415	GOR[2]	11326	337.5
416	GOR[2]	11312	222.5
417	GOR[3]	11298	337.5
418	GOR[3]	11284	222.5
419	GOR[3]	11270	337.5
420	GOR[4]	11256	222.5
421	GOR[4]	11242	337.5
422	GOR[4]	11228	222.5
423	GOR[5]	11214	337.5
424	GOR[5]	11200	222.5
425	GOR[5]	11186	337.5
426	GOR[6]	11172	222.5
427	GOR[6]	11158	337.5
428	GOR[6]	11144	222.5
429	GOR[7]	11130	337.5

PAD No.	PIN Name	X	Y
430	GOR[7]	11116	222.5
431	GOR[7]	11102	337.5
432	GOR[8]	11088	222.5
433	GOR[8]	11074	337.5
434	GOR[8]	11060	222.5
435	GOR[9]	11046	337.5
436	GOR[9]	11032	222.5
437	GOR[9]	11018	337.5
438	GOR[10]	11004	222.5
439	GOR[10]	10990	337.5
440	GOR[10]	10976	222.5
441	VGHS	10906	337.5
442	VGHS	10892	222.5
443	VGHS	10878	337.5
444	VGHS	10864	222.5
445	VGHS	10850	337.5
446	VGHS	10836	222.5
447	VGL	10822	337.5
448	VGL	10808	222.5
449	VGL	10794	337.5
450	VGL	10780	222.5
451	VGL	10766	337.5
452	VGL	10752	222.5
453	DUMMY	10682	337.5
454	DUMMY	10668	222.5
455	DUMMY	10654	337.5
456	DUMMY	10640	222.5
457	DUMMY	10626	337.5
458	DUMMY	10612	222.5
459	DUMMY	10598	337.5
460	DUMMY	10584	222.5
461	DUMMY	10570	337.5
462	DUMMY	10556	222.5

PAD No.	PIN Name	X	Y
463	DUMMY	10542	337.5
464	DUMMY	10528	222.5
465	DUMMY	10514	337.5
466	DUMMY	10500	222.5
467	DUMMY	10486	337.5
468	DUMMY	10472	222.5
469	DUMMY	10458	337.5
470	DUMMY	10444	222.5
471	DUMMY	10430	337.5
472	DUMMY	10416	222.5
473	DUMMY	10402	337.5
474	DUMMY	10388	222.5
475	DUMMY	10374	337.5
476	DUMMY	10360	222.5
477	DUMMY	10346	337.5
478	DUMMY	10332	222.5
479	DUMMY	10318	337.5
480	DUMMY	10304	222.5
481	DUMMY	10290	337.5
482	DUMMY	10276	222.5
483	DUMMY	10262	337.5
484	DUMMY	10248	222.5
485	DUMMY	10234	337.5
486	DUMMY	10220	222.5
487	DUMMY	10206	337.5
488	DUMMY	10192	222.5
489	DUMMY	10178	337.5
490	DUMMY	10164	222.5
491	DUMMY	10150	337.5
492	DUMMY	10136	222.5
493	DUMMY	10122	337.5
494	DUMMY	10108	222.5
495	DUMMY	10094	337.5

PAD No.	PIN Name	X	Y
496	DUMMY	10080	222.5
497	DUMMY	10066	337.5
498	DUMMY	10052	222.5
499	DUMMY	10038	337.5
500	DUMMY	10024	222.5
501	DUMMY	10010	337.5
502	DUMMY	9996	222.5
503	DUMMY	9982	337.5
504	DUMMY	9968	222.5
505	DUMMY	9954	337.5
506	DUMMY	9940	222.5
507	DUMMY	9926	337.5
508	DUMMY	9912	222.5
509	DUMMY	9898	337.5
510	DUMMY	9884	222.5
511	DUMMY	9870	337.5
512	DUMMY	9856	222.5
513	DUMMY	9842	337.5
514	DUMMY	9828	222.5
515	DUMMY	9814	337.5
516	DUMMY	9800	222.5
517	DUMMY	9786	337.5
518	DUMMY	9772	222.5
519	DUMMY	9758	337.5
520	DUMMY	9744	222.5
521	DUMMY	9730	337.5
522	DUMMY	9716	222.5
523	DUMMY	9702	337.5
524	DUMMY	9688	222.5
525	DUMMY	9674	337.5
526	DUMMY	9660	222.5
527	DUMMY	9646	337.5
528	DUMMY	9632	222.5

PAD No.	PIN Name	X	Y
529	DUMMY	9618	337.5
530	DUMMY	9604	222.5
531	DUMMY	9590	337.5
532	DUMMY	9576	222.5
533	DUMMY	9562	337.5
534	DUMMY	9548	222.5
535	DUMMY	9534	337.5
536	DUMMY	9520	222.5
537	DUMMY	9506	337.5
538	DUMMY	9492	222.5
539	DUMMY	9478	337.5
540	DUMMY	9464	222.5
541	DUMMY	9450	337.5
542	DUMMY	9436	222.5
543	DUMMY	9422	337.5
544	DUMMY	9408	222.5
545	DUMMY	9394	337.5
546	DUMMY	9380	222.5
547	DUMMY	9366	337.5
548	DUMMY	9352	222.5
549	DUMMY	9338	337.5
550	DUMMY	9324	222.5
551	SGND	9254	337.5
552	SGND	9240	222.5
553	SGND	9226	337.5
554	SGND	9212	222.5
555	SGND	9198	337.5
556	SGND	9184	222.5
557	SGND	9170	337.5
558	SGND	9156	222.5
559	SGND	9142	337.5
560	SGND	9128	222.5
561	SGND	9114	337.5

PAD No.	PIN Name	X	Y
562	SGND	9100	222.5
563	SGND	9086	337.5
564	SGND	9072	222.5
565	SGND	9058	337.5
566	SGND	9044	222.5
567	S1	8974	337.5
568	S2	8960	222.5
569	S3	8946	337.5
570	S4	8932	222.5
571	S5	8918	337.5
572	S6	8904	222.5
573	S7	8890	337.5
574	S8	8876	222.5
575	S9	8862	337.5
576	S10	8848	222.5
577	S11	8834	337.5
578	S12	8820	222.5
579	S13	8806	337.5
580	S14	8792	222.5
581	S15	8778	337.5
582	S16	8764	222.5
583	S17	8750	337.5
584	S18	8736	222.5
585	S19	8722	337.5
586	S20	8708	222.5
587	S21	8694	337.5
588	S22	8680	222.5
589	S23	8666	337.5
590	S24	8652	222.5
591	S25	8638	337.5
592	S26	8624	222.5
593	S27	8610	337.5
594	S28	8596	222.5

PAD No.	PIN Name	X	Y
595	S29	8582	337.5
596	S30	8568	222.5
597	S31	8554	337.5
598	S32	8540	222.5
599	S33	8526	337.5
600	S34	8512	222.5
601	S35	8498	337.5
602	S36	8484	222.5
603	S37	8470	337.5
604	S38	8456	222.5
605	S39	8442	337.5
606	S40	8428	222.5
607	S41	8414	337.5
608	S42	8400	222.5
609	S43	8386	337.5
610	S44	8372	222.5
611	S45	8358	337.5
612	S46	8344	222.5
613	S47	8330	337.5
614	S48	8316	222.5
615	S49	8302	337.5
616	S50	8288	222.5
617	S51	8274	337.5
618	S52	8260	222.5
619	S53	8246	337.5
620	S54	8232	222.5
621	S55	8218	337.5
622	S56	8204	222.5
623	S57	8190	337.5
624	S58	8176	222.5
625	S59	8162	337.5
626	S60	8148	222.5
627	S61	8134	337.5

PAD No.	PIN Name	X	Y
628	S62	8120	222.5
629	S63	8106	337.5
630	S64	8092	222.5
631	S65	8078	337.5
632	S66	8064	222.5
633	S67	8050	337.5
634	S68	8036	222.5
635	S69	8022	337.5
636	S70	8008	222.5
637	S71	7994	337.5
638	S72	7980	222.5
639	S73	7966	337.5
640	S74	7952	222.5
641	S75	7938	337.5
642	S76	7924	222.5
643	S77	7910	337.5
644	S78	7896	222.5
645	S79	7882	337.5
646	S80	7868	222.5
647	S81	7854	337.5
648	S82	7840	222.5
649	S83	7826	337.5
650	S84	7812	222.5
651	S85	7798	337.5
652	S86	7784	222.5
653	S87	7770	337.5
654	S88	7756	222.5
655	S89	7742	337.5
656	S90	7728	222.5
657	S91	7714	337.5
658	S92	7700	222.5
659	S93	7686	337.5
660	S94	7672	222.5

PAD No.	PIN Name	X	Y
661	S95	7658	337.5
662	S96	7644	222.5
663	S97	7630	337.5
664	S98	7616	222.5
665	S99	7602	337.5
666	S100	7588	222.5
667	S101	7574	337.5
668	S102	7560	222.5
669	S103	7546	337.5
670	S104	7532	222.5
671	S105	7518	337.5
672	S106	7504	222.5
673	S107	7490	337.5
674	S108	7476	222.5
675	S109	7462	337.5
676	S110	7448	222.5
677	S111	7434	337.5
678	S112	7420	222.5
679	S113	7406	337.5
680	S114	7392	222.5
681	S115	7378	337.5
682	S116	7364	222.5
683	S117	7350	337.5
684	S118	7336	222.5
685	S119	7322	337.5
686	S120	7308	222.5
687	S121	7294	337.5
688	S122	7280	222.5
689	S123	7266	337.5
690	S124	7252	222.5
691	S125	7238	337.5
692	S126	7224	222.5
693	S127	7210	337.5

PAD No.	PIN Name	X	Y
694	S128	7196	222.5
695	S129	7182	337.5
696	S130	7168	222.5
697	S131	7154	337.5
698	S132	7140	222.5
699	S133	7126	337.5
700	S134	7112	222.5
701	S135	7098	337.5
702	S136	7084	222.5
703	S137	7070	337.5
704	S138	7056	222.5
705	S139	7042	337.5
706	S140	7028	222.5
707	S141	7014	337.5
708	S142	7000	222.5
709	S143	6986	337.5
710	S144	6972	222.5
711	S145	6958	337.5
712	S146	6944	222.5
713	S147	6930	337.5
714	S148	6916	222.5
715	S149	6902	337.5
716	S150	6888	222.5
717	S151	6874	337.5
718	S152	6860	222.5
719	S153	6846	337.5
720	S154	6832	222.5
721	S155	6818	337.5
722	S156	6804	222.5
723	S157	6790	337.5
724	S158	6776	222.5
725	S159	6762	337.5
726	S160	6748	222.5

PAD No.	PIN Name	X	Y
727	S161	6734	337.5
728	S162	6720	222.5
729	S163	6706	337.5
730	S164	6692	222.5
731	S165	6678	337.5
732	S166	6664	222.5
733	S167	6650	337.5
734	S168	6636	222.5
735	S169	6622	337.5
736	S170	6608	222.5
737	S171	6594	337.5
738	S172	6580	222.5
739	S173	6566	337.5
740	S174	6552	222.5
741	S175	6538	337.5
742	S176	6524	222.5
743	S177	6510	337.5
744	S178	6496	222.5
745	S179	6482	337.5
746	S180	6468	222.5
747	S181	6454	337.5
748	S182	6440	222.5
749	S183	6426	337.5
750	S184	6412	222.5
751	S185	6398	337.5
752	S186	6384	222.5
753	S187	6370	337.5
754	S188	6356	222.5
755	S189	6342	337.5
756	S190	6328	222.5
757	S191	6314	337.5
758	S192	6300	222.5
759	S193	6286	337.5

PAD No.	PIN Name	X	Y
760	S194	6272	222.5
761	S195	6258	337.5
762	S196	6244	222.5
763	S197	6230	337.5
764	S198	6216	222.5
765	S199	6202	337.5
766	S200	6188	222.5
767	S201	6174	337.5
768	S202	6160	222.5
769	S203	6146	337.5
770	S204	6132	222.5
771	S205	6118	337.5
772	S206	6104	222.5
773	S207	6090	337.5
774	S208	6076	222.5
775	S209	6062	337.5
776	S210	6048	222.5
777	S211	6034	337.5
778	S212	6020	222.5
779	S213	6006	337.5
780	S214	5992	222.5
781	S215	5978	337.5
782	S216	5964	222.5
783	S217	5950	337.5
784	S218	5936	222.5
785	S219	5922	337.5
786	S220	5908	222.5
787	S221	5894	337.5
788	S222	5880	222.5
789	S223	5866	337.5
790	S224	5852	222.5
791	S225	5838	337.5
792	S226	5824	222.5

PAD No.	PIN Name	X	Y
793	S227	5810	337.5
794	S228	5796	222.5
795	S229	5782	337.5
796	S230	5768	222.5
797	S231	5754	337.5
798	S232	5740	222.5
799	S233	5726	337.5
800	S234	5712	222.5
801	S235	5698	337.5
802	S236	5684	222.5
803	S237	5670	337.5
804	S238	5656	222.5
805	S239	5642	337.5
806	S240	5628	222.5
807	S241	5614	337.5
808	S242	5600	222.5
809	S243	5586	337.5
810	S244	5572	222.5
811	S245	5558	337.5
812	S246	5544	222.5
813	S247	5530	337.5
814	S248	5516	222.5
815	S249	5502	337.5
816	S250	5488	222.5
817	S251	5474	337.5
818	S252	5460	222.5
819	S253	5446	337.5
820	S254	5432	222.5
821	S255	5418	337.5
822	S256	5404	222.5
823	S257	5390	337.5
824	S258	5376	222.5
825	S259	5362	337.5

PAD No.	PIN Name	X	Y
826	S260	5348	222.5
827	S261	5334	337.5
828	S262	5320	222.5
829	S263	5306	337.5
830	S264	5292	222.5
831	S265	5278	337.5
832	S266	5264	222.5
833	S267	5250	337.5
834	S268	5236	222.5
835	S269	5222	337.5
836	S270	5208	222.5
837	S271	5194	337.5
838	S272	5180	222.5
839	S273	5166	337.5
840	S274	5152	222.5
841	S275	5138	337.5
842	S276	5124	222.5
843	S277	5110	337.5
844	S278	5096	222.5
845	S279	5082	337.5
846	S280	5068	222.5
847	S281	5054	337.5
848	S282	5040	222.5
849	S283	5026	337.5
850	S284	5012	222.5
851	S285	4998	337.5
852	S286	4984	222.5
853	S287	4970	337.5
854	S288	4956	222.5
855	S289	4942	337.5
856	S290	4928	222.5
857	S291	4914	337.5
858	S292	4900	222.5

PAD No.	PIN Name	X	Y	PAD No.	PIN Name	X	Y
859	S293	4886	337.5	892	S310	4312	222.5
860	S294	4872	222.5	893	S311	4298	337.5
861	S295	4858	337.5	894	S312	4284	222.5
862	S296	4844	222.5	895	S313	4270	337.5
863	S297	4830	337.5	896	S314	4256	222.5
864	S298	4816	222.5	897	S315	4242	337.5
865	S299	4802	337.5	898	S316	4228	222.5
866	S300	4788	222.5	899	S317	4214	337.5
867	SGND	4718	337.5	900	S318	4200	222.5
868	SGND	4704	222.5	901	S319	4186	337.5
869	SGND	4690	337.5	902	S320	4172	222.5
870	SGND	4676	222.5	903	S321	4158	337.5
871	SGND	4662	337.5	904	S322	4144	222.5
872	SGND	4648	222.5	905	S323	4130	337.5
873	SGND	4634	337.5	906	S324	4116	222.5
874	SGND	4620	222.5	907	S325	4102	337.5
875	SGND	4606	337.5	908	S326	4088	222.5
876	SGND	4592	222.5	909	S327	4074	337.5
877	SGND	4578	337.5	910	S328	4060	222.5
878	SGND	4564	222.5	911	S329	4046	337.5
879	SGND	4550	337.5	912	S330	4032	222.5
880	SGND	4536	222.5	913	S331	4018	337.5
881	SGND	4522	337.5	914	S332	4004	222.5
882	SGND	4508	222.5	915	S333	3990	337.5
883	S301	4438	337.5	916	S334	3976	222.5
884	S302	4424	222.5	917	S335	3962	337.5
885	S303	4410	337.5	918	S336	3948	222.5
886	S304	4396	222.5	919	S337	3934	337.5
887	S305	4382	337.5	920	S338	3920	222.5
888	S306	4368	222.5	921	S339	3906	337.5
889	S307	4354	337.5	922	S340	3892	222.5
890	S308	4340	222.5	923	S341	3878	337.5
891	S309	4326	337.5	924	S342	3864	222.5

PAD No.	PIN Name	X	Y
925	S343	3850	337.5
926	S344	3836	222.5
927	S345	3822	337.5
928	S346	3808	222.5
929	S347	3794	337.5
930	S348	3780	222.5
931	S349	3766	337.5
932	S350	3752	222.5
933	S351	3738	337.5
934	S352	3724	222.5
935	S353	3710	337.5
936	S354	3696	222.5
937	S355	3682	337.5
938	S356	3668	222.5
939	S357	3654	337.5
940	S358	3640	222.5
941	S359	3626	337.5
942	S360	3612	222.5
943	S361	3598	337.5
944	S362	3584	222.5
945	S363	3570	337.5
946	S364	3556	222.5
947	S365	3542	337.5
948	S366	3528	222.5
949	S367	3514	337.5
950	S368	3500	222.5
951	S369	3486	337.5
952	S370	3472	222.5
953	S371	3458	337.5
954	S372	3444	222.5
955	S373	3430	337.5
956	S374	3416	222.5
957	S375	3402	337.5

PAD No.	PIN Name	X	Y
958	S376	3388	222.5
959	S377	3374	337.5
960	S378	3360	222.5
961	S379	3346	337.5
962	S380	3332	222.5
963	S381	3318	337.5
964	S382	3304	222.5
965	S383	3290	337.5
966	S384	3276	222.5
967	S385	3262	337.5
968	S386	3248	222.5
969	S387	3234	337.5
970	S388	3220	222.5
971	S389	3206	337.5
972	S390	3192	222.5
973	S391	3178	337.5
974	S392	3164	222.5
975	S393	3150	337.5
976	S394	3136	222.5
977	S395	3122	337.5
978	S396	3108	222.5
979	S397	3094	337.5
980	S398	3080	222.5
981	S399	3066	337.5
982	S400	3052	222.5
983	S401	3038	337.5
984	S402	3024	222.5
985	S403	3010	337.5
986	S404	2996	222.5
987	S405	2982	337.5
988	S406	2968	222.5
989	S407	2954	337.5
990	S408	2940	222.5

PAD No.	PIN Name	X	Y
991	S409	2926	337.5
992	S410	2912	222.5
993	S411	2898	337.5
994	S412	2884	222.5
995	S413	2870	337.5
996	S414	2856	222.5
997	S415	2842	337.5
998	S416	2828	222.5
999	S417	2814	337.5
1000	S418	2800	222.5
1001	S419	2786	337.5
1002	S420	2772	222.5
1003	S421	2758	337.5
1004	S422	2744	222.5
1005	S423	2730	337.5
1006	S424	2716	222.5
1007	S425	2702	337.5
1008	S426	2688	222.5
1009	S427	2674	337.5
1010	S428	2660	222.5
1011	S429	2646	337.5
1012	S430	2632	222.5
1013	S431	2618	337.5
1014	S432	2604	222.5
1015	S433	2590	337.5
1016	S434	2576	222.5
1017	S435	2562	337.5
1018	S436	2548	222.5
1019	S437	2534	337.5
1020	S438	2520	222.5
1021	S439	2506	337.5
1022	S440	2492	222.5
1023	S441	2478	337.5

PAD No.	PIN Name	X	Y
1024	S442	2464	222.5
1025	S443	2450	337.5
1026	S444	2436	222.5
1027	S445	2422	337.5
1028	S446	2408	222.5
1029	S447	2394	337.5
1030	S448	2380	222.5
1031	S449	2366	337.5
1032	S450	2352	222.5
1033	S451	2338	337.5
1034	S452	2324	222.5
1035	S453	2310	337.5
1036	S454	2296	222.5
1037	S455	2282	337.5
1038	S456	2268	222.5
1039	S457	2254	337.5
1040	S458	2240	222.5
1041	S459	2226	337.5
1042	S460	2212	222.5
1043	S461	2198	337.5
1044	S462	2184	222.5
1045	S463	2170	337.5
1046	S464	2156	222.5
1047	S465	2142	337.5
1048	S466	2128	222.5
1049	S467	2114	337.5
1050	S468	2100	222.5
1051	S469	2086	337.5
1052	S470	2072	222.5
1053	S471	2058	337.5
1054	S472	2044	222.5
1055	S473	2030	337.5
1056	S474	2016	222.5

PAD No.	PIN Name	X	Y
1057	S475	2002	337.5
1058	S476	1988	222.5
1059	S477	1974	337.5
1060	S478	1960	222.5
1061	S479	1946	337.5
1062	S480	1932	222.5
1063	S481	1918	337.5
1064	S482	1904	222.5
1065	S483	1890	337.5
1066	S484	1876	222.5
1067	S485	1862	337.5
1068	S486	1848	222.5
1069	S487	1834	337.5
1070	S488	1820	222.5
1071	S489	1806	337.5
1072	S490	1792	222.5
1073	S491	1778	337.5
1074	S492	1764	222.5
1075	S493	1750	337.5
1076	S494	1736	222.5
1077	S495	1722	337.5
1078	S496	1708	222.5
1079	S497	1694	337.5
1080	S498	1680	222.5
1081	S499	1666	337.5
1082	S500	1652	222.5
1083	S501	1638	337.5
1084	S502	1624	222.5
1085	S503	1610	337.5
1086	S504	1596	222.5
1087	S505	1582	337.5
1088	S506	1568	222.5
1089	S507	1554	337.5

PAD No.	PIN Name	X	Y
1090	S508	1540	222.5
1091	S509	1526	337.5
1092	S510	1512	222.5
1093	S511	1498	337.5
1094	S512	1484	222.5
1095	S513	1470	337.5
1096	S514	1456	222.5
1097	S515	1442	337.5
1098	S516	1428	222.5
1099	S517	1414	337.5
1100	S518	1400	222.5
1101	S519	1386	337.5
1102	S520	1372	222.5
1103	S521	1358	337.5
1104	S522	1344	222.5
1105	S523	1330	337.5
1106	S524	1316	222.5
1107	S525	1302	337.5
1108	S526	1288	222.5
1109	S527	1274	337.5
1110	S528	1260	222.5
1111	S529	1246	337.5
1112	S530	1232	222.5
1113	S531	1218	337.5
1114	S532	1204	222.5
1115	S533	1190	337.5
1116	S534	1176	222.5
1117	S535	1162	337.5
1118	S536	1148	222.5
1119	S537	1134	337.5
1120	S538	1120	222.5
1121	S539	1106	337.5
1122	S540	1092	222.5

PAD No.	PIN Name	X	Y
1123	S541	1078	337.5
1124	S542	1064	222.5
1125	S543	1050	337.5
1126	S544	1036	222.5
1127	S545	1022	337.5
1128	S546	1008	222.5
1129	S547	994	337.5
1130	S548	980	222.5
1131	S549	966	337.5
1132	S550	952	222.5
1133	S551	938	337.5
1134	S552	924	222.5
1135	S553	910	337.5
1136	S554	896	222.5
1137	S555	882	337.5
1138	S556	868	222.5
1139	S557	854	337.5
1140	S558	840	222.5
1141	S559	826	337.5
1142	S560	812	222.5
1143	S561	798	337.5
1144	S562	784	222.5
1145	S563	770	337.5
1146	S564	756	222.5
1147	S565	742	337.5
1148	S566	728	222.5
1149	S567	714	337.5
1150	S568	700	222.5
1151	S569	686	337.5
1152	S570	672	222.5
1153	S571	658	337.5
1154	S572	644	222.5
1155	S573	630	337.5

PAD No.	PIN Name	X	Y
1156	S574	616	222.5
1157	S575	602	337.5
1158	S576	588	222.5
1159	S577	574	337.5
1160	S578	560	222.5
1161	S579	546	337.5
1162	S580	532	222.5
1163	S581	518	337.5
1164	S582	504	222.5
1165	S583	490	337.5
1166	S584	476	222.5
1167	S585	462	337.5
1168	S586	448	222.5
1169	S587	434	337.5
1170	S588	420	222.5
1171	S589	406	337.5
1172	S590	392	222.5
1173	S591	378	337.5
1174	S592	364	222.5
1175	S593	350	337.5
1176	S594	336	222.5
1177	S595	322	337.5
1178	S596	308	222.5
1179	S597	294	337.5
1180	S598	280	222.5
1181	S599	266	337.5
1182	S600	252	222.5
1183	SGND	182	337.5
1184	SGND	168	222.5
1185	SGND	154	337.5
1186	SGND	140	222.5
1187	SGND	126	337.5
1188	SGND	112	222.5

PAD No.	PIN Name	X	Y
1189	SGND	98	337.5
1190	SGND	84	222.5
1191	SGND	70	337.5
1192	SGND	56	222.5
1193	SGND	42	337.5
1194	SGND	28	222.5
1195	SGND	-28	222.5
1196	SGND	-42	337.5
1197	SGND	-56	222.5
1198	SGND	-70	337.5
1199	SGND	-84	222.5
1200	SGND	-98	337.5
1201	SGND	-112	222.5
1202	SGND	-126	337.5
1203	SGND	-140	222.5
1204	SGND	-154	337.5
1205	SGND	-168	222.5
1206	SGND	-182	337.5
1207	S601	-252	222.5
1208	S602	-266	337.5
1209	S603	-280	222.5
1210	S604	-294	337.5
1211	S605	-308	222.5
1212	S606	-322	337.5
1213	S607	-336	222.5
1214	S608	-350	337.5
1215	S609	-364	222.5
1216	S610	-378	337.5
1217	S611	-392	222.5
1218	S612	-406	337.5
1219	S613	-420	222.5
1220	S614	-434	337.5
1221	S615	-448	222.5

PAD No.	PIN Name	X	Y
1222	S616	-462	337.5
1223	S617	-476	222.5
1224	S618	-490	337.5
1225	S619	-504	222.5
1226	S620	-518	337.5
1227	S621	-532	222.5
1228	S622	-546	337.5
1229	S623	-560	222.5
1230	S624	-574	337.5
1231	S625	-588	222.5
1232	S626	-602	337.5
1233	S627	-616	222.5
1234	S628	-630	337.5
1235	S629	-644	222.5
1236	S630	-658	337.5
1237	S631	-672	222.5
1238	S632	-686	337.5
1239	S633	-700	222.5
1240	S634	-714	337.5
1241	S635	-728	222.5
1242	S636	-742	337.5
1243	S637	-756	222.5
1244	S638	-770	337.5
1245	S639	-784	222.5
1246	S640	-798	337.5
1247	S641	-812	222.5
1248	S642	-826	337.5
1249	S643	-840	222.5
1250	S644	-854	337.5
1251	S645	-868	222.5
1252	S646	-882	337.5
1253	S647	-896	222.5
1254	S648	-910	337.5

PAD No.	PIN Name	X	Y
1255	S649	-924	222.5
1256	S650	-938	337.5
1257	S651	-952	222.5
1258	S652	-966	337.5
1259	S653	-980	222.5
1260	S654	-994	337.5
1261	S655	-1008	222.5
1262	S656	-1022	337.5
1263	S657	-1036	222.5
1264	S658	-1050	337.5
1265	S659	-1064	222.5
1266	S660	-1078	337.5
1267	S661	-1092	222.5
1268	S662	-1106	337.5
1269	S663	-1120	222.5
1270	S664	-1134	337.5
1271	S665	-1148	222.5
1272	S666	-1162	337.5
1273	S667	-1176	222.5
1274	S668	-1190	337.5
1275	S669	-1204	222.5
1276	S670	-1218	337.5
1277	S671	-1232	222.5
1278	S672	-1246	337.5
1279	S673	-1260	222.5
1280	S674	-1274	337.5
1281	S675	-1288	222.5
1282	S676	-1302	337.5
1283	S677	-1316	222.5
1284	S678	-1330	337.5
1285	S679	-1344	222.5
1286	S680	-1358	337.5
1287	S681	-1372	222.5

PAD No.	PIN Name	X	Y
1288	S682	-1386	337.5
1289	S683	-1400	222.5
1290	S684	-1414	337.5
1291	S685	-1428	222.5
1292	S686	-1442	337.5
1293	S687	-1456	222.5
1294	S688	-1470	337.5
1295	S689	-1484	222.5
1296	S690	-1498	337.5
1297	S691	-1512	222.5
1298	S692	-1526	337.5
1299	S693	-1540	222.5
1300	S694	-1554	337.5
1301	S695	-1568	222.5
1302	S696	-1582	337.5
1303	S697	-1596	222.5
1304	S698	-1610	337.5
1305	S699	-1624	222.5
1306	S700	-1638	337.5
1307	S701	-1652	222.5
1308	S702	-1666	337.5
1309	S703	-1680	222.5
1310	S704	-1694	337.5
1311	S705	-1708	222.5
1312	S706	-1722	337.5
1313	S707	-1736	222.5
1314	S708	-1750	337.5
1315	S709	-1764	222.5
1316	S710	-1778	337.5
1317	S711	-1792	222.5
1318	S712	-1806	337.5
1319	S713	-1820	222.5
1320	S714	-1834	337.5

PAD No.	PIN Name	X	Y
1321	S715	-1848	222.5
1322	S716	-1862	337.5
1323	S717	-1876	222.5
1324	S718	-1890	337.5
1325	S719	-1904	222.5
1326	S720	-1918	337.5
1327	S721	-1932	222.5
1328	S722	-1946	337.5
1329	S723	-1960	222.5
1330	S724	-1974	337.5
1331	S725	-1988	222.5
1332	S726	-2002	337.5
1333	S727	-2016	222.5
1334	S728	-2030	337.5
1335	S729	-2044	222.5
1336	S730	-2058	337.5
1337	S731	-2072	222.5
1338	S732	-2086	337.5
1339	S733	-2100	222.5
1340	S734	-2114	337.5
1341	S735	-2128	222.5
1342	S736	-2142	337.5
1343	S737	-2156	222.5
1344	S738	-2170	337.5
1345	S739	-2184	222.5
1346	S740	-2198	337.5
1347	S741	-2212	222.5
1348	S742	-2226	337.5
1349	S743	-2240	222.5
1350	S744	-2254	337.5
1351	S745	-2268	222.5
1352	S746	-2282	337.5
1353	S747	-2296	222.5

PAD No.	PIN Name	X	Y
1354	S748	-2310	337.5
1355	S749	-2324	222.5
1356	S750	-2338	337.5
1357	S751	-2352	222.5
1358	S752	-2366	337.5
1359	S753	-2380	222.5
1360	S754	-2394	337.5
1361	S755	-2408	222.5
1362	S756	-2422	337.5
1363	S757	-2436	222.5
1364	S758	-2450	337.5
1365	S759	-2464	222.5
1366	S760	-2478	337.5
1367	S761	-2492	222.5
1368	S762	-2506	337.5
1369	S763	-2520	222.5
1370	S764	-2534	337.5
1371	S765	-2548	222.5
1372	S766	-2562	337.5
1373	S767	-2576	222.5
1374	S768	-2590	337.5
1375	S769	-2604	222.5
1376	S770	-2618	337.5
1377	S771	-2632	222.5
1378	S772	-2646	337.5
1379	S773	-2660	222.5
1380	S774	-2674	337.5
1381	S775	-2688	222.5
1382	S776	-2702	337.5
1383	S777	-2716	222.5
1384	S778	-2730	337.5
1385	S779	-2744	222.5
1386	S780	-2758	337.5

PAD No.	PIN Name	X	Y
1387	S781	-2772	222.5
1388	S782	-2786	337.5
1389	S783	-2800	222.5
1390	S784	-2814	337.5
1391	S785	-2828	222.5
1392	S786	-2842	337.5
1393	S787	-2856	222.5
1394	S788	-2870	337.5
1395	S789	-2884	222.5
1396	S790	-2898	337.5
1397	S791	-2912	222.5
1398	S792	-2926	337.5
1399	S793	-2940	222.5
1400	S794	-2954	337.5
1401	S795	-2968	222.5
1402	S796	-2982	337.5
1403	S797	-2996	222.5
1404	S798	-3010	337.5
1405	S799	-3024	222.5
1406	S800	-3038	337.5
1407	S801	-3052	222.5
1408	S802	-3066	337.5
1409	S803	-3080	222.5
1410	S804	-3094	337.5
1411	S805	-3108	222.5
1412	S806	-3122	337.5
1413	S807	-3136	222.5
1414	S808	-3150	337.5
1415	S809	-3164	222.5
1416	S810	-3178	337.5
1417	S811	-3192	222.5
1418	S812	-3206	337.5
1419	S813	-3220	222.5

PAD No.	PIN Name	X	Y
1420	S814	-3234	337.5
1421	S815	-3248	222.5
1422	S816	-3262	337.5
1423	S817	-3276	222.5
1424	S818	-3290	337.5
1425	S819	-3304	222.5
1426	S820	-3318	337.5
1427	S821	-3332	222.5
1428	S822	-3346	337.5
1429	S823	-3360	222.5
1430	S824	-3374	337.5
1431	S825	-3388	222.5
1432	S826	-3402	337.5
1433	S827	-3416	222.5
1434	S828	-3430	337.5
1435	S829	-3444	222.5
1436	S830	-3458	337.5
1437	S831	-3472	222.5
1438	S832	-3486	337.5
1439	S833	-3500	222.5
1440	S834	-3514	337.5
1441	S835	-3528	222.5
1442	S836	-3542	337.5
1443	S837	-3556	222.5
1444	S838	-3570	337.5
1445	S839	-3584	222.5
1446	S840	-3598	337.5
1447	S841	-3612	222.5
1448	S842	-3626	337.5
1449	S843	-3640	222.5
1450	S844	-3654	337.5
1451	S845	-3668	222.5
1452	S846	-3682	337.5

PAD No.	PIN Name	X	Y
1453	S847	-3696	222.5
1454	S848	-3710	337.5
1455	S849	-3724	222.5
1456	S850	-3738	337.5
1457	S851	-3752	222.5
1458	S852	-3766	337.5
1459	S853	-3780	222.5
1460	S854	-3794	337.5
1461	S855	-3808	222.5
1462	S856	-3822	337.5
1463	S857	-3836	222.5
1464	S858	-3850	337.5
1465	S859	-3864	222.5
1466	S860	-3878	337.5
1467	S861	-3892	222.5
1468	S862	-3906	337.5
1469	S863	-3920	222.5
1470	S864	-3934	337.5
1471	S865	-3948	222.5
1472	S866	-3962	337.5
1473	S867	-3976	222.5
1474	S868	-3990	337.5
1475	S869	-4004	222.5
1476	S870	-4018	337.5
1477	S871	-4032	222.5
1478	S872	-4046	337.5
1479	S873	-4060	222.5
1480	S874	-4074	337.5
1481	S875	-4088	222.5
1482	S876	-4102	337.5
1483	S877	-4116	222.5
1484	S878	-4130	337.5
1485	S879	-4144	222.5

PAD No.	PIN Name	X	Y
1486	S880	-4158	337.5
1487	S881	-4172	222.5
1488	S882	-4186	337.5
1489	S883	-4200	222.5
1490	S884	-4214	337.5
1491	S885	-4228	222.5
1492	S886	-4242	337.5
1493	S887	-4256	222.5
1494	S888	-4270	337.5
1495	S889	-4284	222.5
1496	S890	-4298	337.5
1497	S891	-4312	222.5
1498	S892	-4326	337.5
1499	S893	-4340	222.5
1500	S894	-4354	337.5
1501	S895	-4368	222.5
1502	S896	-4382	337.5
1503	S897	-4396	222.5
1504	S898	-4410	337.5
1505	S899	-4424	222.5
1506	S900	-4438	337.5
1507	SGND	-4508	222.5
1508	SGND	-4522	337.5
1509	SGND	-4536	222.5
1510	SGND	-4550	337.5
1511	SGND	-4564	222.5
1512	SGND	-4578	337.5
1513	SGND	-4592	222.5
1514	SGND	-4606	337.5
1515	SGND	-4620	222.5
1516	SGND	-4634	337.5
1517	SGND	-4648	222.5
1518	SGND	-4662	337.5

PAD No.	PIN Name	X	Y
1519	SGND	-4676	222.5
1520	SGND	-4690	337.5
1521	SGND	-4704	222.5
1522	SGND	-4718	337.5
1523	S901	-4788	222.5
1524	S902	-4802	337.5
1525	S903	-4816	222.5
1526	S904	-4830	337.5
1527	S905	-4844	222.5
1528	S906	-4858	337.5
1529	S907	-4872	222.5
1530	S908	-4886	337.5
1531	S909	-4900	222.5
1532	S910	-4914	337.5
1533	S911	-4928	222.5
1534	S912	-4942	337.5
1535	S913	-4956	222.5
1536	S914	-4970	337.5
1537	S915	-4984	222.5
1538	S916	-4998	337.5
1539	S917	-5012	222.5
1540	S918	-5026	337.5
1541	S919	-5040	222.5
1542	S920	-5054	337.5
1543	S921	-5068	222.5
1544	S922	-5082	337.5
1545	S923	-5096	222.5
1546	S924	-5110	337.5
1547	S925	-5124	222.5
1548	S926	-5138	337.5
1549	S927	-5152	222.5
1550	S928	-5166	337.5
1551	S929	-5180	222.5

PAD No.	PIN Name	X	Y
1552	S930	-5194	337.5
1553	S931	-5208	222.5
1554	S932	-5222	337.5
1555	S933	-5236	222.5
1556	S934	-5250	337.5
1557	S935	-5264	222.5
1558	S936	-5278	337.5
1559	S937	-5292	222.5
1560	S938	-5306	337.5
1561	S939	-5320	222.5
1562	S940	-5334	337.5
1563	S941	-5348	222.5
1564	S942	-5362	337.5
1565	S943	-5376	222.5
1566	S944	-5390	337.5
1567	S945	-5404	222.5
1568	S946	-5418	337.5
1569	S947	-5432	222.5
1570	S948	-5446	337.5
1571	S949	-5460	222.5
1572	S950	-5474	337.5
1573	S951	-5488	222.5
1574	S952	-5502	337.5
1575	S953	-5516	222.5
1576	S954	-5530	337.5
1577	S955	-5544	222.5
1578	S956	-5558	337.5
1579	S957	-5572	222.5
1580	S958	-5586	337.5
1581	S959	-5600	222.5
1582	S960	-5614	337.5
1583	S961	-5628	222.5
1584	S962	-5642	337.5

PAD No.	PIN Name	X	Y
1585	S963	-5656	222.5
1586	S964	-5670	337.5
1587	S965	-5684	222.5
1588	S966	-5698	337.5
1589	S967	-5712	222.5
1590	S968	-5726	337.5
1591	S969	-5740	222.5
1592	S970	-5754	337.5
1593	S971	-5768	222.5
1594	S972	-5782	337.5
1595	S973	-5796	222.5
1596	S974	-5810	337.5
1597	S975	-5824	222.5
1598	S976	-5838	337.5
1599	S977	-5852	222.5
1600	S978	-5866	337.5
1601	S979	-5880	222.5
1602	S980	-5894	337.5
1603	S981	-5908	222.5
1604	S982	-5922	337.5
1605	S983	-5936	222.5
1606	S984	-5950	337.5
1607	S985	-5964	222.5
1608	S986	-5978	337.5
1609	S987	-5992	222.5
1610	S988	-6006	337.5
1611	S989	-6020	222.5
1612	S990	-6034	337.5
1613	S991	-6048	222.5
1614	S992	-6062	337.5
1615	S993	-6076	222.5
1616	S994	-6090	337.5
1617	S995	-6104	222.5

PAD No.	PIN Name	X	Y
1618	S996	-6118	337.5
1619	S997	-6132	222.5
1620	S998	-6146	337.5
1621	S999	-6160	222.5
1622	S1000	-6174	337.5
1623	S1001	-6188	222.5
1624	S1002	-6202	337.5
1625	S1003	-6216	222.5
1626	S1004	-6230	337.5
1627	S1005	-6244	222.5
1628	S1006	-6258	337.5
1629	S1007	-6272	222.5
1630	S1008	-6286	337.5
1631	S1009	-6300	222.5
1632	S1010	-6314	337.5
1633	S1011	-6328	222.5
1634	S1012	-6342	337.5
1635	S1013	-6356	222.5
1636	S1014	-6370	337.5
1637	S1015	-6384	222.5
1638	S1016	-6398	337.5
1639	S1017	-6412	222.5
1640	S1018	-6426	337.5
1641	S1019	-6440	222.5
1642	S1020	-6454	337.5
1643	S1021	-6468	222.5
1644	S1022	-6482	337.5
1645	S1023	-6496	222.5
1646	S1024	-6510	337.5
1647	S1025	-6524	222.5
1648	S1026	-6538	337.5
1649	S1027	-6552	222.5
1650	S1028	-6566	337.5

PAD No.	PIN Name	X	Y
1651	S1029	-6580	222.5
1652	S1030	-6594	337.5
1653	S1031	-6608	222.5
1654	S1032	-6622	337.5
1655	S1033	-6636	222.5
1656	S1034	-6650	337.5
1657	S1035	-6664	222.5
1658	S1036	-6678	337.5
1659	S1037	-6692	222.5
1660	S1038	-6706	337.5
1661	S1039	-6720	222.5
1662	S1040	-6734	337.5
1663	S1041	-6748	222.5
1664	S1042	-6762	337.5
1665	S1043	-6776	222.5
1666	S1044	-6790	337.5
1667	S1045	-6804	222.5
1668	S1046	-6818	337.5
1669	S1047	-6832	222.5
1670	S1048	-6846	337.5
1671	S1049	-6860	222.5
1672	S1050	-6874	337.5
1673	S1051	-6888	222.5
1674	S1052	-6902	337.5
1675	S1053	-6916	222.5
1676	S1054	-6930	337.5
1677	S1055	-6944	222.5
1678	S1056	-6958	337.5
1679	S1057	-6972	222.5
1680	S1058	-6986	337.5
1681	S1059	-7000	222.5
1682	S1060	-7014	337.5
1683	S1061	-7028	222.5

PAD No.	PIN Name	X	Y
1684	S1062	-7042	337.5
1685	S1063	-7056	222.5
1686	S1064	-7070	337.5
1687	S1065	-7084	222.5
1688	S1066	-7098	337.5
1689	S1067	-7112	222.5
1690	S1068	-7126	337.5
1691	S1069	-7140	222.5
1692	S1070	-7154	337.5
1693	S1071	-7168	222.5
1694	S1072	-7182	337.5
1695	S1073	-7196	222.5
1696	S1074	-7210	337.5
1697	S1075	-7224	222.5
1698	S1076	-7238	337.5
1699	S1077	-7252	222.5
1700	S1078	-7266	337.5
1701	S1079	-7280	222.5
1702	S1080	-7294	337.5
1703	S1081	-7308	222.5
1704	S1082	-7322	337.5
1705	S1083	-7336	222.5
1706	S1084	-7350	337.5
1707	S1085	-7364	222.5
1708	S1086	-7378	337.5
1709	S1087	-7392	222.5
1710	S1088	-7406	337.5
1711	S1089	-7420	222.5
1712	S1090	-7434	337.5
1713	S1091	-7448	222.5
1714	S1092	-7462	337.5
1715	S1093	-7476	222.5
1716	S1094	-7490	337.5

PAD No.	PIN Name	X	Y
1717	S1095	-7504	222.5
1718	S1096	-7518	337.5
1719	S1097	-7532	222.5
1720	S1098	-7546	337.5
1721	S1099	-7560	222.5
1722	S1100	-7574	337.5
1723	S1101	-7588	222.5
1724	S1102	-7602	337.5
1725	S1103	-7616	222.5
1726	S1104	-7630	337.5
1727	S1105	-7644	222.5
1728	S1106	-7658	337.5
1729	S1107	-7672	222.5
1730	S1108	-7686	337.5
1731	S1109	-7700	222.5
1732	S1110	-7714	337.5
1733	S1111	-7728	222.5
1734	S1112	-7742	337.5
1735	S1113	-7756	222.5
1736	S1114	-7770	337.5
1737	S1115	-7784	222.5
1738	S1116	-7798	337.5
1739	S1117	-7812	222.5
1740	S1118	-7826	337.5
1741	S1119	-7840	222.5
1742	S1120	-7854	337.5
1743	S1121	-7868	222.5
1744	S1122	-7882	337.5
1745	S1123	-7896	222.5
1746	S1124	-7910	337.5
1747	S1125	-7924	222.5
1748	S1126	-7938	337.5
1749	S1127	-7952	222.5

PAD No.	PIN Name	X	Y
1750	S1128	-7966	337.5
1751	S1129	-7980	222.5
1752	S1130	-7994	337.5
1753	S1131	-8008	222.5
1754	S1132	-8022	337.5
1755	S1133	-8036	222.5
1756	S1134	-8050	337.5
1757	S1135	-8064	222.5
1758	S1136	-8078	337.5
1759	S1137	-8092	222.5
1760	S1138	-8106	337.5
1761	S1139	-8120	222.5
1762	S1140	-8134	337.5
1763	S1141	-8148	222.5
1764	S1142	-8162	337.5
1765	S1143	-8176	222.5
1766	S1144	-8190	337.5
1767	S1145	-8204	222.5
1768	S1146	-8218	337.5
1769	S1147	-8232	222.5
1770	S1148	-8246	337.5
1771	S1149	-8260	222.5
1772	S1150	-8274	337.5
1773	S1151	-8288	222.5
1774	S1152	-8302	337.5
1775	S1153	-8316	222.5
1776	S1154	-8330	337.5
1777	S1155	-8344	222.5
1778	S1156	-8358	337.5
1779	S1157	-8372	222.5
1780	S1158	-8386	337.5
1781	S1159	-8400	222.5
1782	S1160	-8414	337.5

PAD No.	PIN Name	X	Y
1783	S1161	-8428	222.5
1784	S1162	-8442	337.5
1785	S1163	-8456	222.5
1786	S1164	-8470	337.5
1787	S1165	-8484	222.5
1788	S1166	-8498	337.5
1789	S1167	-8512	222.5
1790	S1168	-8526	337.5
1791	S1169	-8540	222.5
1792	S1170	-8554	337.5
1793	S1171	-8568	222.5
1794	S1172	-8582	337.5
1795	S1173	-8596	222.5
1796	S1174	-8610	337.5
1797	S1175	-8624	222.5
1798	S1176	-8638	337.5
1799	S1177	-8652	222.5
1800	S1178	-8666	337.5
1801	S1179	-8680	222.5
1802	S1180	-8694	337.5
1803	S1181	-8708	222.5
1804	S1182	-8722	337.5
1805	S1183	-8736	222.5
1806	S1184	-8750	337.5
1807	S1185	-8764	222.5
1808	S1186	-8778	337.5
1809	S1187	-8792	222.5
1810	S1188	-8806	337.5
1811	S1189	-8820	222.5
1812	S1190	-8834	337.5
1813	S1191	-8848	222.5
1814	S1192	-8862	337.5
1815	S1193	-8876	222.5

PAD No.	PIN Name	X	Y
1816	S1194	-8890	337.5
1817	S1195	-8904	222.5
1818	S1196	-8918	337.5
1819	S1197	-8932	222.5
1820	S1198	-8946	337.5
1821	S1199	-8960	222.5
1822	S1200	-8974	337.5
1823	SGND	-9044	222.5
1824	SGND	-9058	337.5
1825	SGND	-9072	222.5
1826	SGND	-9086	337.5
1827	SGND	-9100	222.5
1828	SGND	-9114	337.5
1829	SGND	-9128	222.5
1830	SGND	-9142	337.5
1831	SGND	-9156	222.5
1832	SGND	-9170	337.5
1833	SGND	-9184	222.5
1834	SGND	-9198	337.5
1835	SGND	-9212	222.5
1836	SGND	-9226	337.5
1837	SGND	-9240	222.5
1838	SGND	-9254	337.5
1839	DUMMY	-9324	222.5
1840	DUMMY	-9338	337.5
1841	DUMMY	-9352	222.5
1842	DUMMY	-9366	337.5
1843	DUMMY	-9380	222.5
1844	DUMMY	-9394	337.5
1845	DUMMY	-9408	222.5
1846	DUMMY	-9422	337.5
1847	DUMMY	-9436	222.5
1848	DUMMY	-9450	337.5

PAD No.	PIN Name	X	Y
1849	DUMMY	-9464	222.5
1850	DUMMY	-9478	337.5
1851	DUMMY	-9492	222.5
1852	DUMMY	-9506	337.5
1853	DUMMY	-9520	222.5
1854	DUMMY	-9534	337.5
1855	DUMMY	-9548	222.5
1856	DUMMY	-9562	337.5
1857	DUMMY	-9576	222.5
1858	DUMMY	-9590	337.5
1859	DUMMY	-9604	222.5
1860	DUMMY	-9618	337.5
1861	DUMMY	-9632	222.5
1862	DUMMY	-9646	337.5
1863	DUMMY	-9660	222.5
1864	DUMMY	-9674	337.5
1865	DUMMY	-9688	222.5
1866	DUMMY	-9702	337.5
1867	DUMMY	-9716	222.5
1868	DUMMY	-9730	337.5
1869	DUMMY	-9744	222.5
1870	DUMMY	-9758	337.5
1871	DUMMY	-9772	222.5
1872	DUMMY	-9786	337.5
1873	DUMMY	-9800	222.5
1874	DUMMY	-9814	337.5
1875	DUMMY	-9828	222.5
1876	DUMMY	-9842	337.5
1877	DUMMY	-9856	222.5
1878	DUMMY	-9870	337.5
1879	DUMMY	-9884	222.5
1880	DUMMY	-9898	337.5
1881	DUMMY	-9912	222.5

PAD No.	PIN Name	X	Y
1882	DUMMY	-9926	337.5
1883	DUMMY	-9940	222.5
1884	DUMMY	-9954	337.5
1885	DUMMY	-9968	222.5
1886	DUMMY	-9982	337.5
1887	DUMMY	-9996	222.5
1888	DUMMY	-10010	337.5
1889	DUMMY	-10024	222.5
1890	DUMMY	-10038	337.5
1891	DUMMY	-10052	222.5
1892	DUMMY	-10066	337.5
1893	DUMMY	-10080	222.5
1894	DUMMY	-10094	337.5
1895	DUMMY	-10108	222.5
1896	DUMMY	-10122	337.5
1897	DUMMY	-10136	222.5
1898	DUMMY	-10150	337.5
1899	DUMMY	-10164	222.5
1900	DUMMY	-10178	337.5
1901	DUMMY	-10192	222.5
1902	DUMMY	-10206	337.5
1903	DUMMY	-10220	222.5
1904	DUMMY	-10234	337.5
1905	DUMMY	-10248	222.5
1906	DUMMY	-10262	337.5
1907	DUMMY	-10276	222.5
1908	DUMMY	-10290	337.5
1909	DUMMY	-10304	222.5
1910	DUMMY	-10318	337.5
1911	DUMMY	-10332	222.5
1912	DUMMY	-10346	337.5
1913	DUMMY	-10360	222.5
1914	DUMMY	-10374	337.5

PAD No.	PIN Name	X	Y
1915	DUMMY	-10388	222.5
1916	DUMMY	-10402	337.5
1917	DUMMY	-10416	222.5
1918	DUMMY	-10430	337.5
1919	DUMMY	-10444	222.5
1920	DUMMY	-10458	337.5
1921	DUMMY	-10472	222.5
1922	DUMMY	-10486	337.5
1923	DUMMY	-10500	222.5
1924	DUMMY	-10514	337.5
1925	DUMMY	-10528	222.5
1926	DUMMY	-10542	337.5
1927	DUMMY	-10556	222.5
1928	DUMMY	-10570	337.5
1929	DUMMY	-10584	222.5
1930	DUMMY	-10598	337.5
1931	DUMMY	-10612	222.5
1932	DUMMY	-10626	337.5
1933	DUMMY	-10640	222.5
1934	DUMMY	-10654	337.5
1935	DUMMY	-10668	222.5
1936	DUMMY	-10682	337.5
1937	VGL	-10752	222.5
1938	VGL	-10766	337.5
1939	VGL	-10780	222.5
1940	VGL	-10794	337.5
1941	VGL	-10808	222.5
1942	VGL	-10822	337.5
1943	VGHS	-10836	222.5
1944	VGHS	-10850	337.5
1945	VGHS	-10864	222.5
1946	VGHS	-10878	337.5
1947	VGHS	-10892	222.5

PAD No.	PIN Name	X	Y
1948	VGHS	-10906	337.5
1949	GOL[10]	-10976	222.5
1950	GOL[10]	-10990	337.5
1951	GOL[10]	-11004	222.5
1952	GOL[9]	-11018	337.5
1953	GOL[9]	-11032	222.5
1954	GOL[9]	-11046	337.5
1955	GOL[8]	-11060	222.5
1956	GOL[8]	-11074	337.5
1957	GOL[8]	-11088	222.5
1958	GOL[7]	-11102	337.5
1959	GOL[7]	-11116	222.5
1960	GOL[7]	-11130	337.5
1961	GOL[6]	-11144	222.5
1962	GOL[6]	-11158	337.5
1963	GOL[6]	-11172	222.5
1964	GOL[5]	-11186	337.5
1965	GOL[5]	-11200	222.5
1966	GOL[5]	-11214	337.5
1967	GOL[4]	-11228	222.5
1968	GOL[4]	-11242	337.5
1969	GOL[4]	-11256	222.5
1970	GOL[3]	-11270	337.5
1971	GOL[3]	-11284	222.5
1972	GOL[3]	-11298	337.5
1973	GOL[2]	-11312	222.5
1974	GOL[2]	-11326	337.5
1975	GOL[2]	-11340	222.5
1976	GOL[1]	-11354	337.5
1977	GOL[1]	-11368	222.5
1978	GOL[1]	-11382	337.5
1979	GOL[12]	-11452	222.5
1980	GOL[12]	-11466	337.5

PAD No.	PIN Name	X	Y
1981	GOL[12]	-11480	222.5
1982	GOL[11]	-11494	337.5
1983	GOL[11]	-11508	222.5
1984	GOL[11]	-11522	337.5
1985	VGHS	-11536	222.5
1986	VGHS	-11550	337.5
1987	VGHS	-11564	222.5
1988	VGHS	-11578	337.5
1989	VGHS	-11592	222.5
1990	VGHS	-11606	337.5
1991	L_MARK	-11812	-337
1992	R_MARK	11812	-337

5. BLOCK DIAGRAM

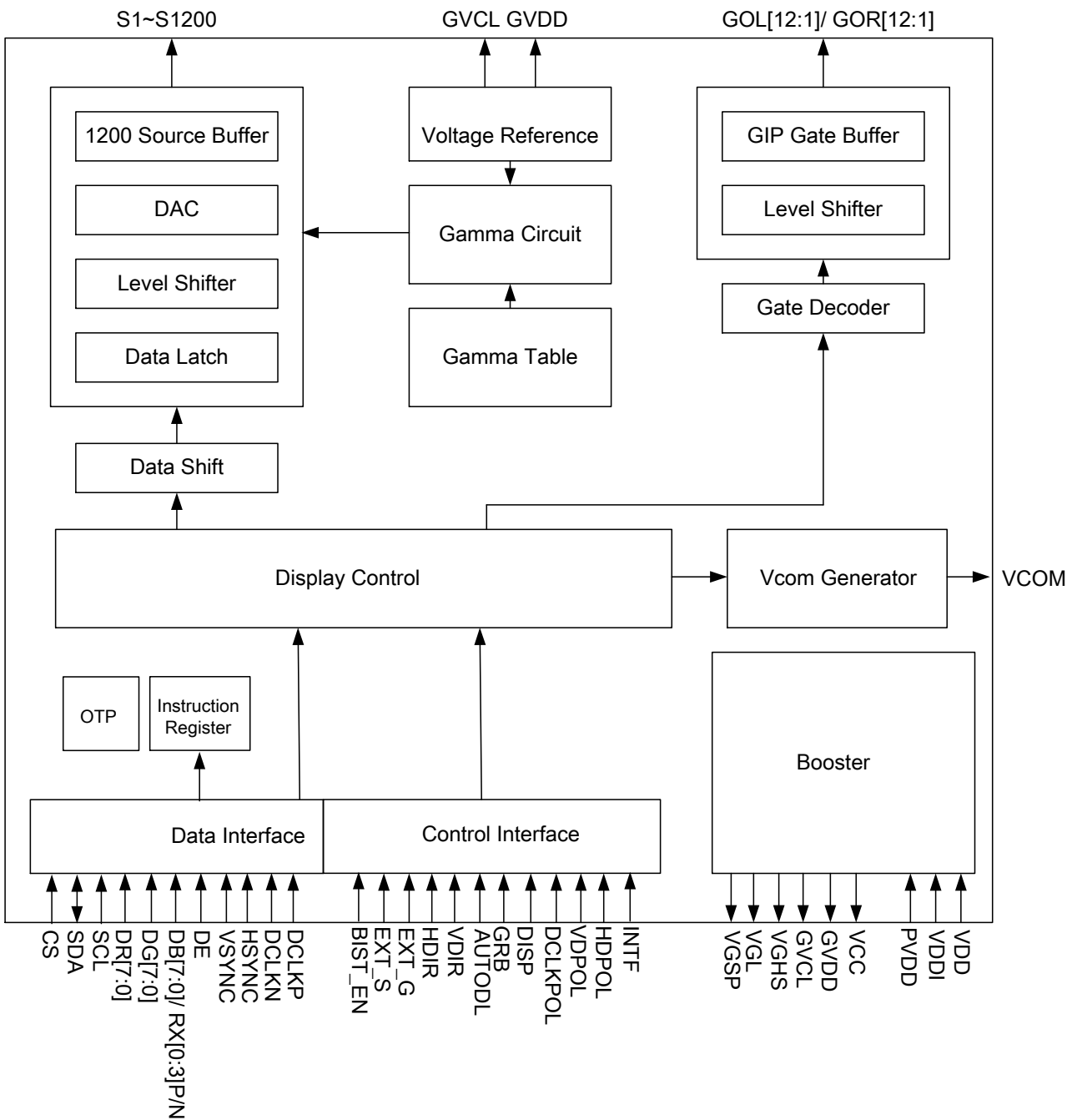

6. PIN DESCRIPTION

6.1 Pin Function

Name	Type	Description								
3-Wire SPI Interface Pins										
CS	I	Serial communication chip selection.								
SDA	I/O	Serial communication data input and output.								
SCL	I	Serial communication clock input.								
Control Pins										
EXT_S	I	Power mode setting								
		<table border="1"> <thead> <tr> <th>EXT_S</th> <th>Function Description</th> </tr> </thead> <tbody> <tr> <td>L</td> <td>1 power mode (Internal pump mode)</td> </tr> <tr> <td>H</td> <td>3 Power Mode (Charge pump controller)</td> </tr> <tr> <td></td> <td>3 Power Mode (External power supply)</td> </tr> </tbody> </table>	EXT_S	Function Description	L	1 power mode (Internal pump mode)	H	3 Power Mode (Charge pump controller)		3 Power Mode (External power supply)
		EXT_S	Function Description							
		L	1 power mode (Internal pump mode)							
H	3 Power Mode (Charge pump controller)									
	3 Power Mode (External power supply)									
VCSW[2:1]	O	PFM and Power IC control output for DC/DC converter.								
GRB	I	Global reset pin. When GRB is "L", internal initialization procedure is executed.								
DISP	I	DISP sets the display mode.								
		<table border="1"> <thead> <tr> <th>DISP</th> <th>Function Description</th> </tr> </thead> <tbody> <tr> <td>L</td> <td>Standby mode(Default)</td> </tr> <tr> <td>H</td> <td>Normal display mode</td> </tr> </tbody> </table>	DISP	Function Description	L	Standby mode(Default)	H	Normal display mode		
		DISP	Function Description							
		L	Standby mode(Default)							
H	Normal display mode									
HDIR	I	Horizontal scan direction control pin. This pin must be connected to "H" or "L" according to system application.								
		<table border="1"> <thead> <tr> <th>HDIR</th> <th>Function Description</th> </tr> </thead> <tbody> <tr> <td>L</td> <td>From right to left</td> </tr> <tr> <td>H</td> <td>From left to right(Default)</td> </tr> </tbody> </table>	HDIR	Function Description	L	From right to left	H	From left to right(Default)		
		HDIR	Function Description							
		L	From right to left							
H	From left to right(Default)									
VDIR	I	Vertical scan direction control pin. This pin must be connected to "H" or "L" according to system application.								
		<table border="1"> <thead> <tr> <th>VDIR</th> <th>Function Description</th> </tr> </thead> <tbody> <tr> <td>L</td> <td>From down to up</td> </tr> <tr> <td>H</td> <td>From up to down(Default)</td> </tr> </tbody> </table>	VDIR	Function Description	L	From down to up	H	From up to down(Default)		
		VDIR	Function Description							
		L	From down to up							
H	From up to down(Default)									
AUTODL	I	OTP trim function control pin. When normal display, AUTODL should be set to "H" and the value in the OTP will be downloaded automatically.								
		<table border="1"> <thead> <tr> <th>AUTODL</th> <th>Function Description</th> </tr> </thead> <tbody> <tr> <td>L</td> <td>Disable auto-refresh function</td> </tr> <tr> <td>H</td> <td>Enable auto-refresh function(Default)</td> </tr> </tbody> </table>	AUTODL	Function Description	L	Disable auto-refresh function	H	Enable auto-refresh function(Default)		
		AUTODL	Function Description							
		L	Disable auto-refresh function							
H	Enable auto-refresh function(Default)									

Name	Type	Description													
BIST_EN	I	BIST function control pin.													
		<table border="1"> <thead> <tr> <th>BIST_EN</th> <th>Function Description</th> </tr> </thead> <tbody> <tr> <td>L</td> <td>Disable BIST function(Default)</td> </tr> <tr> <td>H</td> <td>Enable BIST function</td> </tr> </tbody> </table>	BIST_EN	Function Description	L	Disable BIST function(Default)	H	Enable BIST function							
		BIST_EN	Function Description												
L	Disable BIST function(Default)														
H	Enable BIST function														
INTF	I	Set RGB interface or LVDS interface.													
		<table border="1"> <thead> <tr> <th>INTF</th> <th>Function Description</th> </tr> </thead> <tbody> <tr> <td>L</td> <td>RGB interface mode(Default)</td> </tr> <tr> <td>H</td> <td>LVDS interface mode</td> </tr> </tbody> </table>	INTF	Function Description	L	RGB interface mode(Default)	H	LVDS interface mode							
		INTF	Function Description												
L	RGB interface mode(Default)														
H	LVDS interface mode														
Interface Control Pins															
VDPOL_LVDS_SEL	I	VDPOL_LVDS_SEL sets VSYNC polarity in RGB interface and data format 3, 4 lane in LVDS interface.													
		<table border="1"> <thead> <tr> <th>MCU Type</th> <th>VDPOL_LVDS_SEL</th> <th>Function Description</th> </tr> </thead> <tbody> <tr> <td rowspan="2">RGB interface</td> <td>L</td> <td>VSYNC polarity: positive</td> </tr> <tr> <td>H</td> <td>VSYNC polarity: negative(Default)</td> </tr> <tr> <td rowspan="2">LVDS interface</td> <td>L</td> <td>LVDS 3 lane</td> </tr> <tr> <td>H</td> <td>LVDS 4 lane(Default)</td> </tr> </tbody> </table>	MCU Type	VDPOL_LVDS_SEL	Function Description	RGB interface	L	VSYNC polarity: positive	H	VSYNC polarity: negative(Default)	LVDS interface	L	LVDS 3 lane	H	LVDS 4 lane(Default)
		MCU Type	VDPOL_LVDS_SEL	Function Description											
		RGB interface	L	VSYNC polarity: positive											
			H	VSYNC polarity: negative(Default)											
LVDS interface	L	LVDS 3 lane													
	H	LVDS 4 lane(Default)													
HDPOL	I	HDPOL sets HSYNC polarity in RGB interface.													
		<table border="1"> <thead> <tr> <th>HDPOL</th> <th>Function Description</th> </tr> </thead> <tbody> <tr> <td>L</td> <td>HSYNC polarity: positive</td> </tr> <tr> <td>H</td> <td>HSYNC polarity: negative(Default)</td> </tr> </tbody> </table>	HDPOL	Function Description	L	HSYNC polarity: positive	H	HSYNC polarity: negative(Default)							
		HDPOL	Function Description												
L	HSYNC polarity: positive														
H	HSYNC polarity: negative(Default)														
HDPOL pin should be connected to "H" when it is used in LVDS interface.															
DCLKPOL	I	DCLKPOL sets DCLK polarity in RGB interface.													
		<table border="1"> <thead> <tr> <th>DCLKPOL</th> <th>Function Description</th> </tr> </thead> <tbody> <tr> <td>L</td> <td>DCLK polarity: positive</td> </tr> <tr> <td>H</td> <td>DCLK polarity: negative(Default)</td> </tr> </tbody> </table>	DCLKPOL	Function Description	L	DCLK polarity: positive	H	DCLK polarity: negative(Default)							
		DCLKPOL	Function Description												
L	DCLK polarity: positive														
H	DCLK polarity: negative(Default)														
DCLKPOL pin should be connected to "H" when it is used in LVDS interface.															
LVDS_FMT	I	LVDS_FMT sets LVDS data format.													
		<table border="1"> <thead> <tr> <th>LVDS_FMT</th> <th>Function Description</th> </tr> </thead> <tbody> <tr> <td>L</td> <td>VESA Mode</td> </tr> <tr> <td>H</td> <td>JEIDA Mode(Default)</td> </tr> </tbody> </table>	LVDS_FMT	Function Description	L	VESA Mode	H	JEIDA Mode(Default)							
		LVDS_FMT	Function Description												
L	VESA Mode														
H	JEIDA Mode(Default)														
LVDS_FMT pin should be connected to "L" when it is used in RGB interface.															

Input Interface Pins																									
DR[7:0] DG[7:0] DB[7:0]	I	<p>RGB interface and LVDS interface data input pins.</p> <p>LVDS pin definition. Please refer to LVDS Input Pin Mapping Table.</p> <table border="1"> <thead> <tr> <th>MCU Type</th> <th colspan="2">Function Description</th> </tr> </thead> <tbody> <tr> <td rowspan="3">RGB interface</td> <td>DR[7:0]</td> <td>8 bit data bus display red data.</td> </tr> <tr> <td>DG[7:0]</td> <td>8 bit data bus display green data.</td> </tr> <tr> <td>DB[7:0]</td> <td>8 bit data bus display blue data.</td> </tr> <tr> <td rowspan="5">LVDS interface</td> <td>DR[7:0]</td> <td>DR[7:0] are not used in LVDS mode and should be connected to "L".</td> </tr> <tr> <td>DG[7:0]</td> <td>DG[7:0] are not used in LVDS mode and should be connected to "L".</td> </tr> <tr> <td>DB[1:0]</td> <td>LVDS input lane: RX0N/ RX0P</td> </tr> <tr> <td>DB[3:2]</td> <td>LVDS input lane: RX1N/ RX1P</td> </tr> <tr> <td>DB[5:4]</td> <td>LVDS input lane: RX2N/ RX2P</td> </tr> <tr> <td>DB[7:6]</td> <td>LVDS input lane: RX3N/ RX3P</td> </tr> </tbody> </table>	MCU Type	Function Description		RGB interface	DR[7:0]	8 bit data bus display red data.	DG[7:0]	8 bit data bus display green data.	DB[7:0]	8 bit data bus display blue data.	LVDS interface	DR[7:0]	DR[7:0] are not used in LVDS mode and should be connected to "L".	DG[7:0]	DG[7:0] are not used in LVDS mode and should be connected to "L".	DB[1:0]	LVDS input lane: RX0N/ RX0P	DB[3:2]	LVDS input lane: RX1N/ RX1P	DB[5:4]	LVDS input lane: RX2N/ RX2P	DB[7:6]	LVDS input lane: RX3N/ RX3P
		MCU Type	Function Description																						
		RGB interface	DR[7:0]	8 bit data bus display red data.																					
			DG[7:0]	8 bit data bus display green data.																					
			DB[7:0]	8 bit data bus display blue data.																					
		LVDS interface	DR[7:0]	DR[7:0] are not used in LVDS mode and should be connected to "L".																					
			DG[7:0]	DG[7:0] are not used in LVDS mode and should be connected to "L".																					
			DB[1:0]	LVDS input lane: RX0N/ RX0P																					
			DB[3:2]	LVDS input lane: RX1N/ RX1P																					
DB[5:4]	LVDS input lane: RX2N/ RX2P																								
DB[7:6]	LVDS input lane: RX3N/ RX3P																								
DCLKP	I	<p>Pixel clock/ RXCLKP control pin, this pin function is selected by INTF.</p> <table border="1"> <thead> <tr> <th>MCU Type</th> <th>Function Description</th> </tr> </thead> <tbody> <tr> <td>RGB interface</td> <td>Pixel clock input pin</td> </tr> <tr> <td>LVDS interface</td> <td>RXCLKP control pin. This is LVDS clock input pin, detail pin define please refer to LVDS Input Pin Mapping Table</td> </tr> </tbody> </table>	MCU Type	Function Description	RGB interface	Pixel clock input pin	LVDS interface	RXCLKP control pin. This is LVDS clock input pin, detail pin define please refer to LVDS Input Pin Mapping Table																	
		MCU Type	Function Description																						
		RGB interface	Pixel clock input pin																						
LVDS interface	RXCLKP control pin. This is LVDS clock input pin, detail pin define please refer to LVDS Input Pin Mapping Table																								
DCLKN	I	<p>RXCLKN control pin, this pin function is selected by INTF.</p> <table border="1"> <thead> <tr> <th>MCU Type</th> <th>Function Description</th> </tr> </thead> <tbody> <tr> <td>RGB interface</td> <td>RGB interface: DCLKN is not used in RGB interface and should be connected to "L".</td> </tr> <tr> <td>LVDS interface</td> <td>LVDS clock input pin, detail pin define please refer to LVDS Input Pin Mapping Table.</td> </tr> </tbody> </table>	MCU Type	Function Description	RGB interface	RGB interface: DCLKN is not used in RGB interface and should be connected to "L".	LVDS interface	LVDS clock input pin, detail pin define please refer to LVDS Input Pin Mapping Table.																	
		MCU Type	Function Description																						
		RGB interface	RGB interface: DCLKN is not used in RGB interface and should be connected to "L".																						
LVDS interface	LVDS clock input pin, detail pin define please refer to LVDS Input Pin Mapping Table.																								
HSYNC	I	<p>Horizontal sync signal applied to the RGB interface.</p> <p>HSYNC pin should be connected to "L" when it is used in LVDS interface.</p>																							
VSYNC	I	<p>Vertical sync signal applied to the RGB interface.</p> <p>VSYNC pin should be connected to "L" when it is used in LVDS interface.</p>																							
DE	I	<p>Data input enable applied to the RGB interface.</p> <p>DE pin should be connected to "L" when it is used in LVDS interface.</p>																							
Source / Gate Driver Pins																									
S[1200:1]	O	Source driver output signals.																							
GOR[12:1] GOL[12:1]	O	GIP control signals																							

VCOM Generator Pin		
VCOM	C	Power supply for the TFT-LCD common electrode.
Power Supply Pins		
VDD	P	Power supply for analog circuit.
VDDI	P	Power supply for digital I/O pins.
PVDD	P	Power supply for charge pump circuit.
DGND	P	Ground pin for digital circuit.
AGND	P	Ground pin for analog circuit.
RGND	P	Ground pin for reference circuit.
SGND	P	Ground pin for source circuit.
PGND	P	Ground pin for charge pump circuit.
Power Circuit Pins		
SVDD	C	DC/DC converter for positive source OP-AMP driver.
AVDD1	C	DC/DC converter for positive gamma voltage.
SVCL	C	DC/DC converter for negative source OP-AMP driver.
AVCL1	C	DC/DC converter for negative gamma voltage.
VCC	C	Internal digital power.
VGHS	C	Positive power supply for gate driver.
VGL	C	Negative power supply for gate driver.
Test Pins		
GVDD	T	Monitor pin of internal positive grayscale power.
GVCL	T	Monitor pin of internal negative grayscale power.
VGSP	T	Monitor pin of internal VCOM offset.
VPP	T	Reserved for test only, please leave it open.
EXT_G	T	Reserved for test only, please connect to "L".
TESTI[14:0]	T	Reserved for test only, please leave those pins open.
TESTOUT[13:0]	T	Reserved for test only, please leave those pins open.
DUMMY	D	Dummy pin, please leave those pins open.

Note: 1. I: input, O: output, I/O: input/output, P: power input, PO: power out, D: dummy, T: test pin, C: capacitor pin

2. If hardware pin is not used, please fix to "H" by VDDI or "L" by DGND

7. COMMUNICATION INTERFACE

7.1 3-wire Serial Interface

R/W: Read/Write mode control bit.
 R/W=1: Read mode
 R/W=0: Write mode

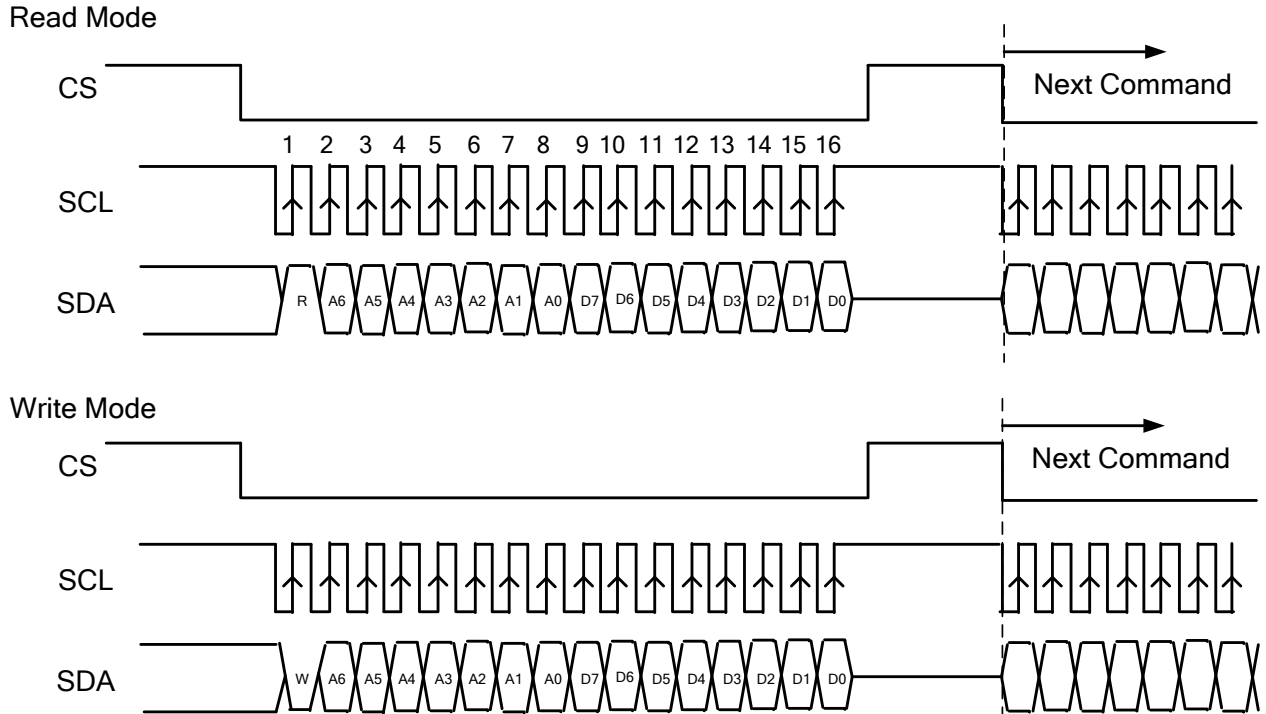

- a. Each serial command consists of 16 bits of data which is loaded one bit a time at the rising edge of serial clock SCL.
- b. Command loading operation starts from the falling edge of CS and is completed at the next rising edge of CS.
- c. The serial control block is operational after power on reset, but commands are established by the VSYNC signal. If command is transferred multiple times for the same register, the last command before the VSYNC signal is valid.
- d. If less than 16 bits of SCL are input while CS is low, the transferred data is ignored.
- e. If 16 bits or more of SCL are input while CS is low, the previous 16 bits of transferred data before then rising edge of CS pulse are valid data.
- f. Serial block operates with the SCL clock
- g. Serial data can be accepted in the power save mode.
- h. After power on reset or GRB reset, it is required 100ms delay to begin SPI communication.

7.2 RGB Interface

RGB Mode Selection Table	DCLK	HSYNC	VSYNC	DE
SYNC - DE Mode	Input	Input	Input	Input
SYNC Mode	Input	Input	Input	GND
DE Mode	Input	GND	GND	Input

Note: "Input" means these signals are driven by host side

7.2.1 SYNC Mode

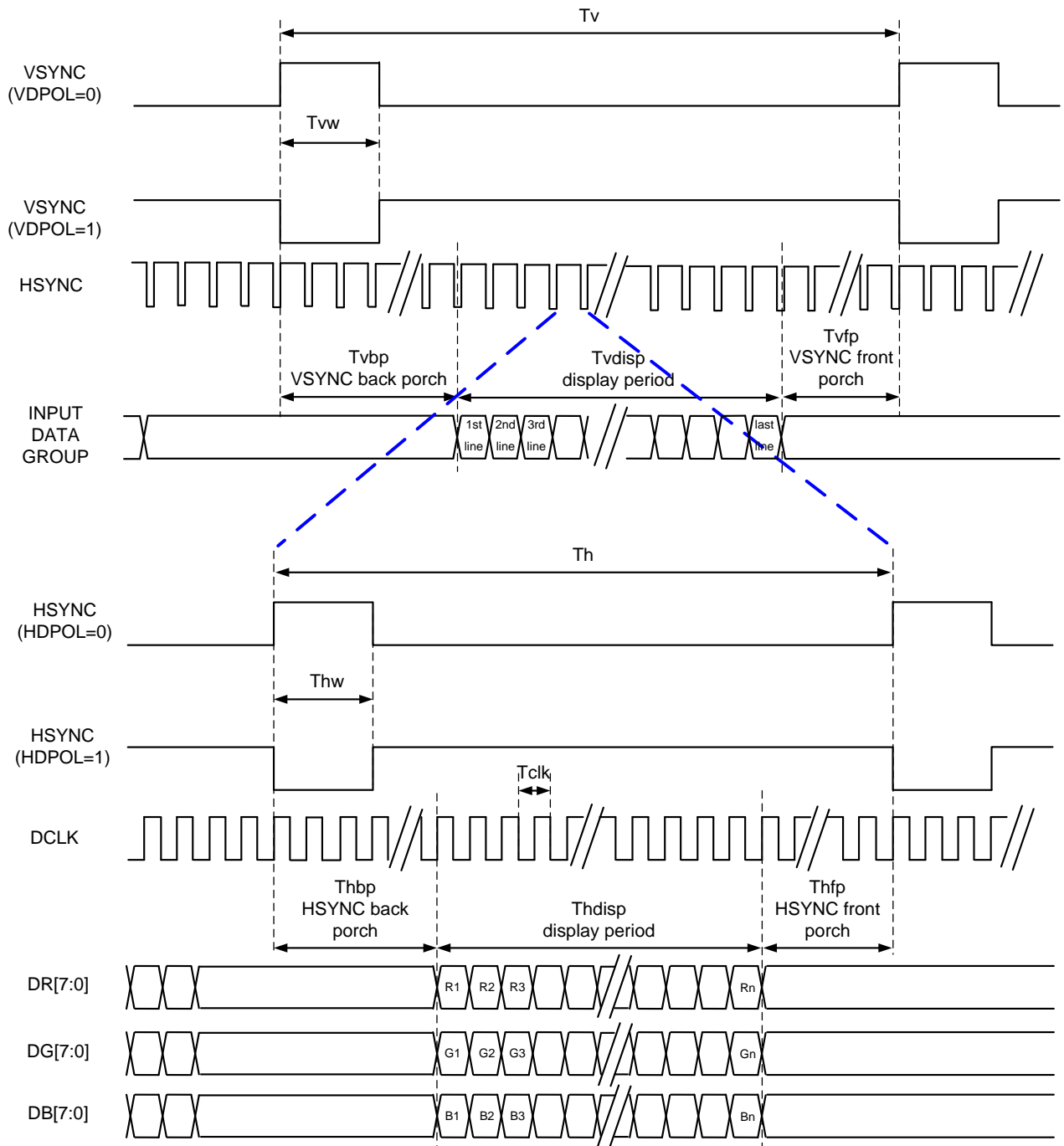

7.2.2 SYNC-DE Mode

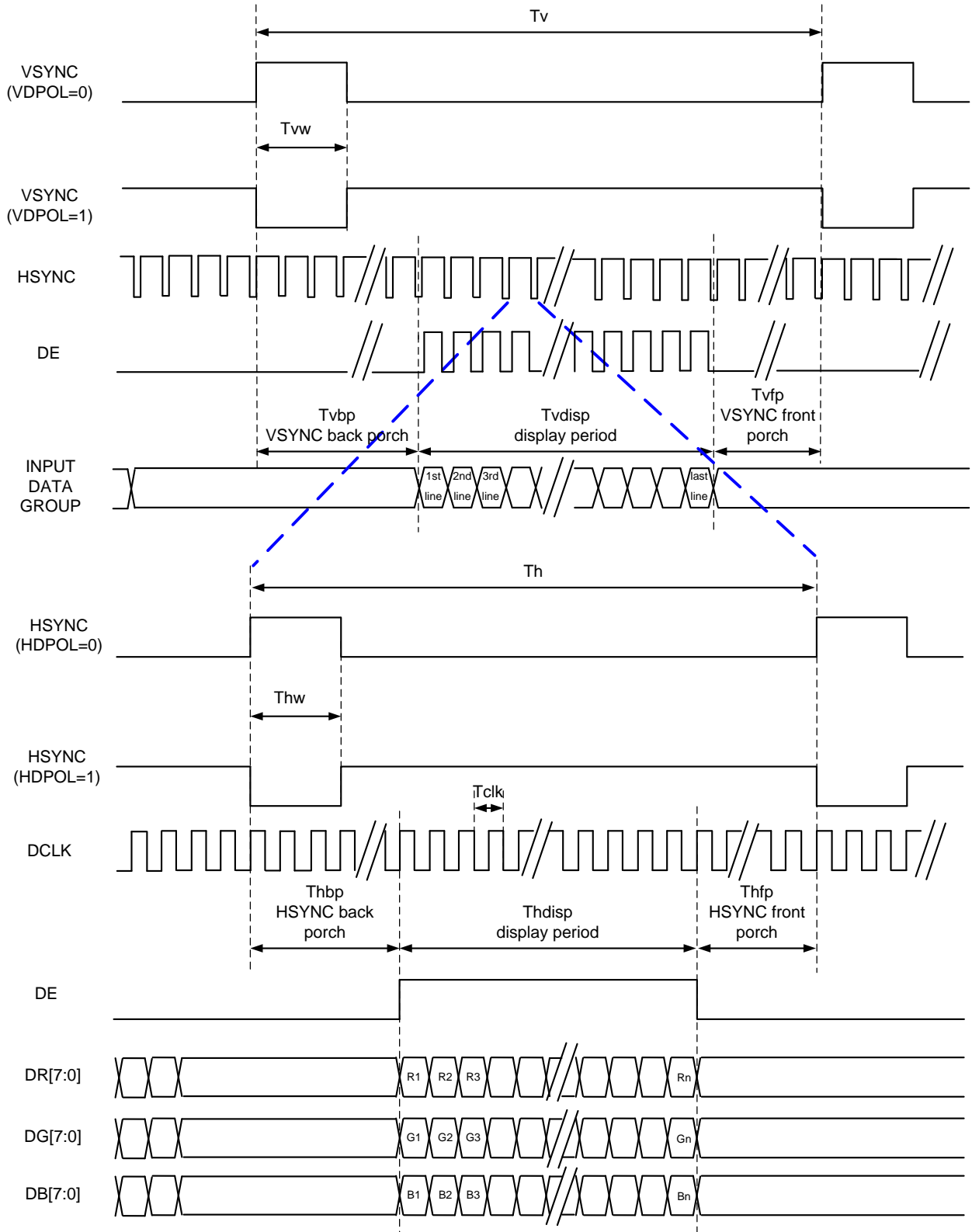

7.2.3 DE Mode

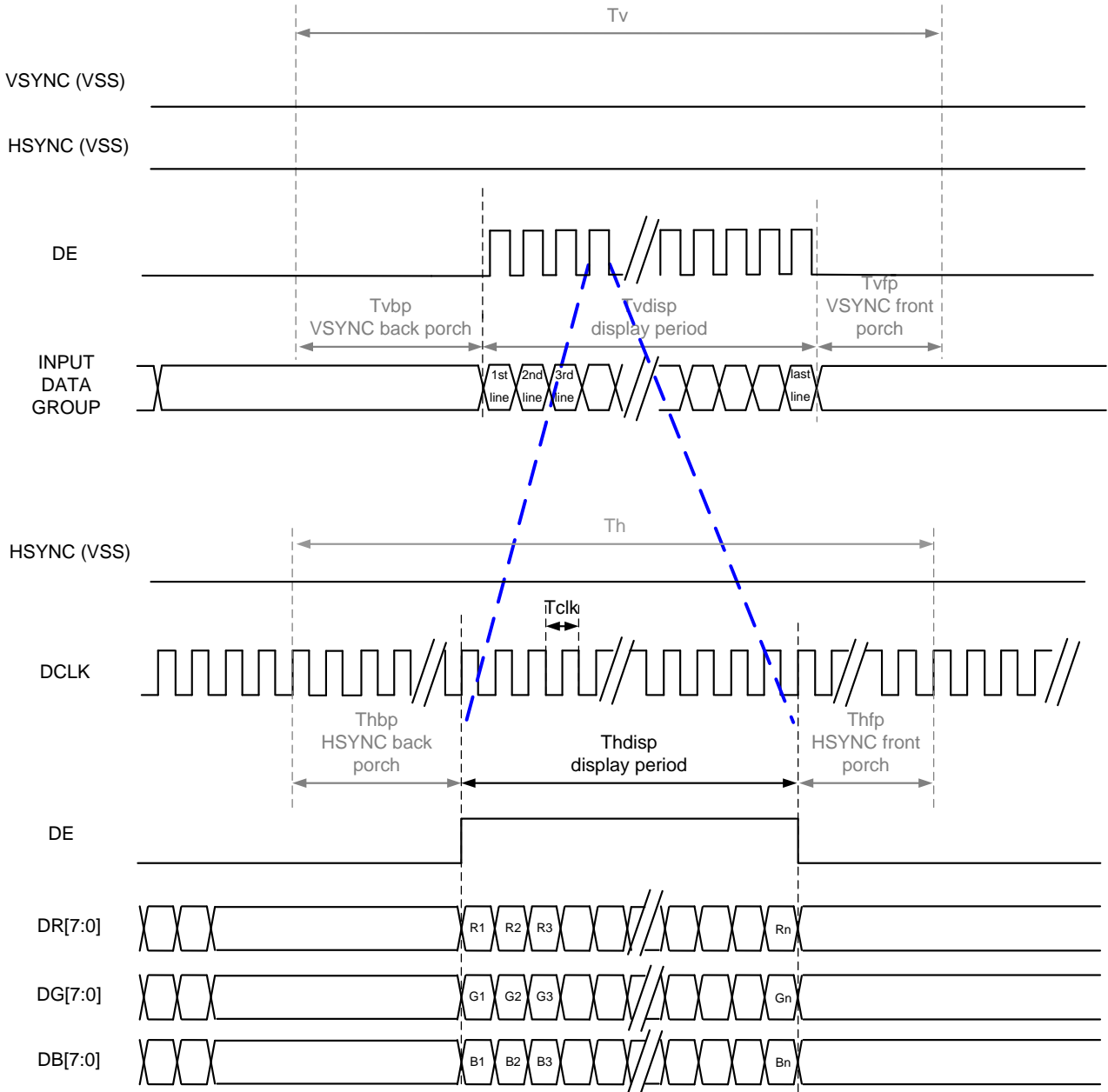

7.2.4 Parallel 24-bit RGB Input Timing Table

Parallel 24-bit RGB Input Timing (PVDD=VDD=VDDI= 3.3V, AGND= 0V, TA=25°C)

Parallel 24-bit RGB Interface Timing Table							
Item	Symbol	Min.	Typ.	Max.	Unit	Remark	
DCLK Frequency	Fclk	23	25	27	MHz	.	
HSYNC	Period Time	Th	808	816	848	DCLK	
	Display Period	Thdisp	800			DCLK	
	Back Porch	Thbp	4	8	24	DCLK	
	Front Porch	Thfp	4	8	24	DCLK	
	Pulse Width	Thw	2	4	8	DCLK	
VSYNC	Period Time	Tv	496	512	528	HSYNC	
	Display Period	Tvdisp	480			HSYNC	
	Back Porch	Tvbp	8	16	24	HSYNC	
	Front Porch	Tvfp	8	16	24	HSYNC	
	Pulse Width	Tvw	2	4	8	HSYNC	

- Note: 1. The minimum blanking time depends on the GIP timing of the panel specification
2. To ensure the compatibility of different panels, it is recommended to use the typical setting.
3. It is necessary to keep Tvbp =16 and Thbp =8 in sync mode. DE mode is unnecessary to keep it.

7.3 LVDS Interface

7.3.1 LVDS Input Pin Mapping Table

Pin Name RGB (LVDS)	LVDS 3 lane	LVDS 4 Lane
DCLKN	RXCLKN	RXCLKN
DCLKP	RXCLKP	RXCLKP
DB0	RX0P	RX0P
DB1	RX0N	RX0N
DB2	RX1P	RX1P
DB3	RX1N	RX1N
DB4	RX2P	RX2P
DB5	RX2N	RX2N
DB6	-	RX3P
DB7	-	RX3N

Note: Symbol "-" means reserve pin and should fix to "L" by DGND.

7.3.2 4 Lane VESA Data Format Color Bit Map

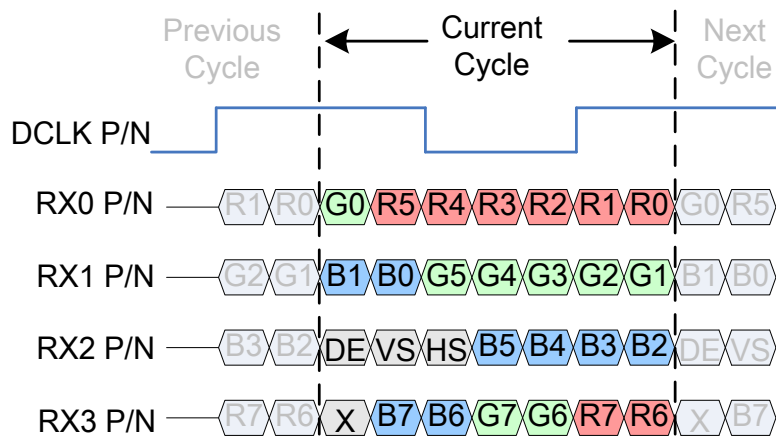

7.3.3 4 Lane JEIDA Data Format Color Bit Map

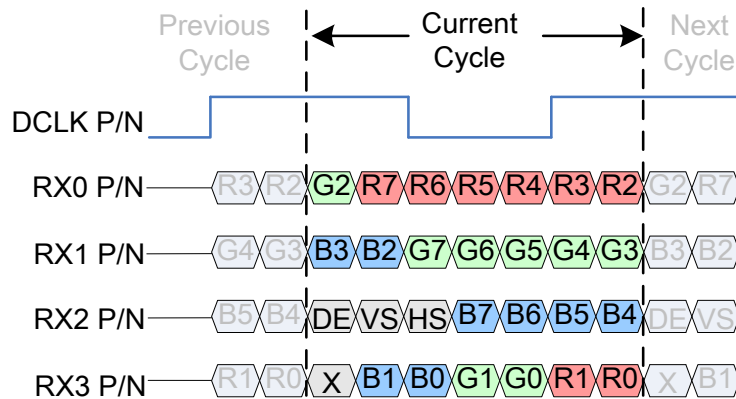

7.3.4 3 Lane VESA Mode Color Bit Map

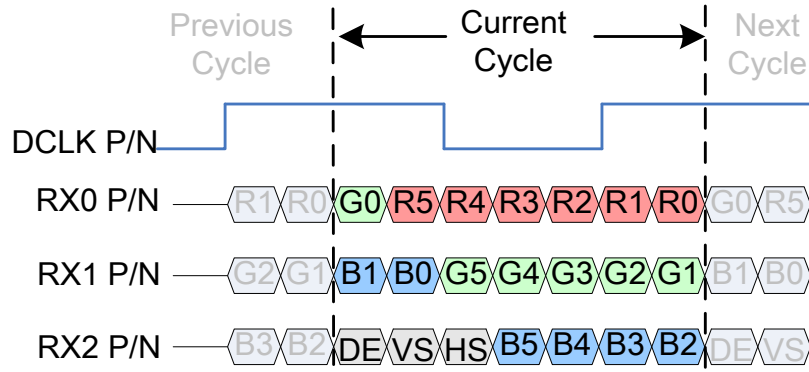

7.3.5 3 Lane JEIDA Mode Color Bit Map

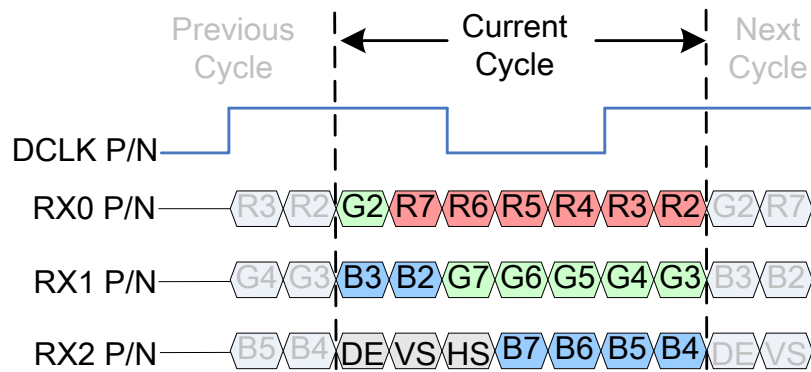

7.3.6 LVDS Input Timing Table

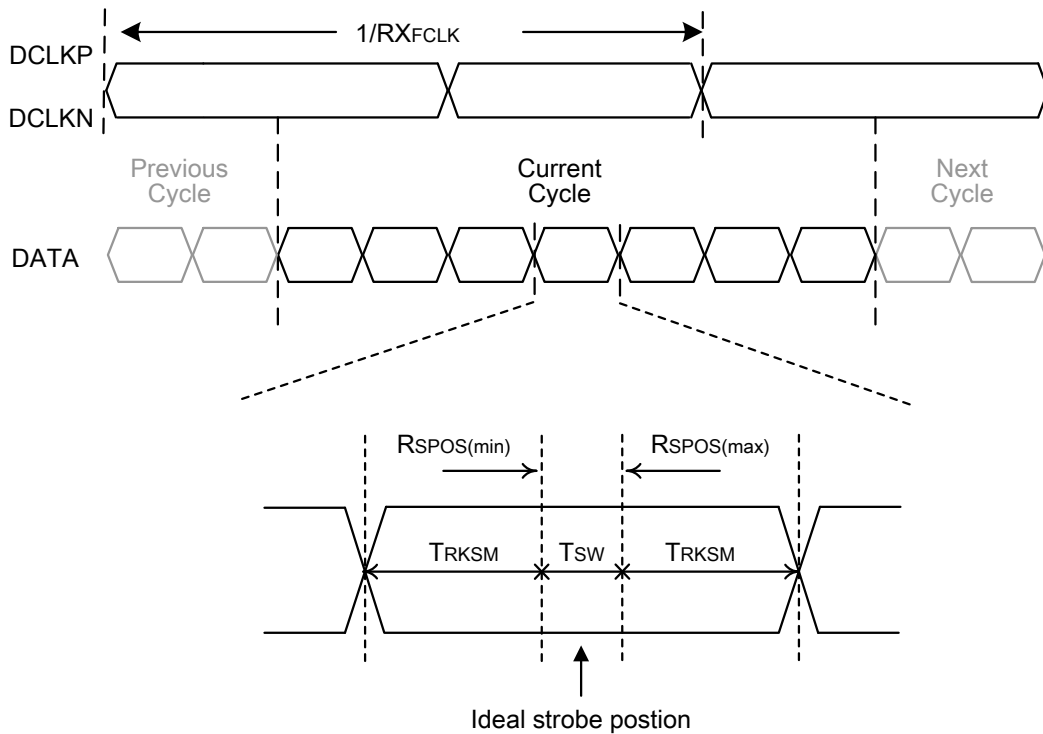

RRKSM : Receiver strobe margin
 RSPOS : Receiver strobe position
 Tsw : Strobe width (internal DATA sampling window)

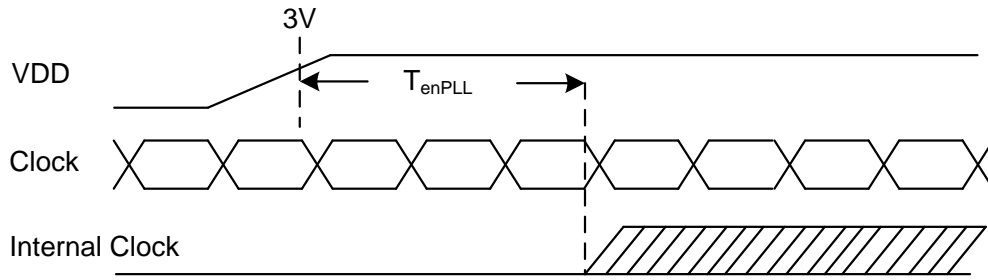

LVDS Input Timing (PVDD=VDD=VDDI= 3.3V, AGND= 0V, TA=25°C)

Item	Symbol	Min.	Typ.	Max.	Unit	Conditions
Clock Frequency	RX_{FCLK}	23	25	30	MHz	
Input Data Skew Margin	T_{RSKM}	400	-	-	ps	
Clock High Time	T_{LVCH}	$4/(7 \times RX_{FCLK})$			ns	
Clock Low Time	T_{LVCL}	$3/(7 \times RX_{FCLK})$			ns	
PLL Wake-up Time	T_{enPLL}	-	-	150	us	
LVDS Spread Spectrum Clocking (SSC) Tolerance of LVDS Receiver						
Modulation Frequency	SSC_{MF}	-	-	100	KHz	
Modulation Rate	SSC_{MR}	-	-	+/-3	%	

8. REGISTER LIST

8.1 Register Summary

COMMAND TABLE1										
Address	Type	D7	D6	D5	D4	D3	D2	D1	D0	Default
10h	W	0	0	0	0	GRB	0	0	DISP	08h
11h	W	CONTRAST[7:0]								40h
12h	W	0	SUB_CONTRAST_R[6:0]							40h
13h	W	0	SUB_CONTRAST_B[6:0]							40h
14h	W	BRIGHTNESS[7:0]								40h
15h	W	0	SUB_BRIGHTNESS_R[6:0]							40h
16h	W	0	SUB_BRIGHTNESS_B[6:0]							40h
17h	W	H_BLANKING[7:0]								08h
18h	W	V_BLANKING[7:0]								10h
1Ch	W	0	0	0	0	0	AUTODL	0	0	--
COMMAND TABLE2										
Address	Type	D7	D6	D5	D4	D3	D2	D1	D0	Default
40h	R/W	0	VRHP[6:0]							--
41h	R/W	0	VRHN[6:0]							--
45h	R/W	VGL[2:0]			1	VGHS[2:0]			1	--

Note: 1. When GRB is "Low", all registers reset to default values.

2. Symbol "--" means this value is OTP setting according to parameters of system application, panel loading and display quality.

3. Do not use instructions not listed in these tables.

GAMMA COMMAND TABLE										
Address	TYPE	D7	D6	D5	D4	D3	D2	D1	D0	Default
20h	R/W	0	RATIO1[1:0]		VRF0P[4:0]					--
21h	R/W	0	PFP6[3]	PFP0[3]	VOS0P[4:0]					--
22h	R/W	PFP0[2:0]			PKP0[4:0]					--
23h	R/W	PFP1[2:0]			PKP1[4:0]					--
24h	R/W	PFP2[2:0]			PKP2[4:0]					--
25h	R/W	PFP3[2:0]			PKP3[4:0]					--
26h	R/W	PFP4[2:0]			PKP4[4:0]					--
27h	R/W	PFP5[2:0]			PKP5[4:0]					--
28h	R/W	PFP6[2:0]			PKP6[4:0]					--
29h	R/W	0	0	0	PKP7[4:0]					--
30h	R/W	0	RATIO2[1:0]		VRF0N[4:0]					--
31h	R/W	0	PFN6[3]	PFN0[3]	VOS0N[4:0]					--
32h	R/W	PFN0[2:0]			PKN0[4:0]					--
33h	R/W	PFN1[2:0]			PKN1[4:0]					--
34h	R/W	PFN2[2:0]			PKN2[4:0]					--
35h	R/W	PFN3[2:0]			PKN3[4:0]					--
36h	R/W	PFN4[2:0]			PKN4[4:0]					--
37h	R/W	PFN5[2:0]			PKN5[4:0]					--
38h	R/W	PFN6[2:0]			PKN6[4:0]					--
39h	R/W	0	0	0	PKN7[4:0]					--

Note: 1. When GRB is "Low", all registers reset to default values.

2. Symbol "--" means this value is OTP setting according to parameters of system application, panel loading and display quality.

3. Do not use instructions not listed in these tables.

OTP COMMAND TABLE											
Address	TYPE	D7	D6	D5	D4	D3	D2	D1	D0	Default	
01h	R/W	0	ID1[6:0]								--
02h	R/W	0	ID2[6:0]								--
03h	R/W	0	ID3[6:0]								--
05h	R/W	0	VMF[6:0]								40h
60h	W	0	1	0	0	0	1	OTPEN	0	44h	
65h	W	OTPACK[7:0]								00h	
68h	R	0	0	0	0	0	ID1 OTP TIME[2:0]		--		
69h	R	0	0	0	0	0	ID2 OTP TIME[2:0]		--		
6Ah	R	0	0	0	0	0	ID3 OTP TIME[2:0]		--		
6Ch	R	0	0	0	0	0	VMF OTP TIME[2:0]		--		

Note: 1. When GRB is "Low", all registers reset to default values.

2. Symbol "--" means this value is OTP setting according to parameters of system application, panel loading and display quality.

3. Do not use instructions not listed in these tables.

8.2 Command Table1 Register Description

8.2.1 GRB、DISP CONTROL (10h)

Address	TYPE	D7	D6	D5	D4	D3	D2	D1	D0	Default
10h	W	0	0	0	0	GRB	0	0	DISP	08h

Designation	Description
GRB	Reset register setting GRB=0: reset all registers to default value GRB=1: normal operation
DISP	Display on/off control DISP=0: standby mode DISP=1: normal mode

8.2.2 CONTRAST (11h)

Address	TYPE	D7	D6	D5	D4	D3	D2	D1	D0	Default
11h	W	CONTRAST[7:0]								40h

Designation	Description
CONTRAST[7:0]	Set RGB contrast level, the range of gain is 0~3.984 CONTRAST=00h: contrast gain=0 CONTRAST=40h: contrast gain=1 CONTRAST=FFh: contrast gain=3.984

8.2.3 SUB_CONTRAST_R (12h)

Address	TYPE	D7	D6	D5	D4	D3	D2	D1	D0	Default
12h	W	0	SUB_CONTRAST_R[6:0]							40h

Designation	Description
SUB_CONTRAST_R[6:0]	Set red color sub-contrast level, the range of gain is 0.75~1.246 SUB_CONTRAST_R=00h: contrast gain=0.75 SUB_CONTRAST_R=40h: contrast gain=1 SUB_CONTRAST_R=7Fh: contrast gain=1.246

8.2.4 SUB_CONTRAST_B (13h)

Address	TYPE	D7	D6	D5	D4	D3	D2	D1	D0	Default
13h	W	0	SUB_CONTRAST_B[6:0]						40h	

Designation	Description
SUB_CONTRAST_B[6:0]	Set blue color sub-contrast level, the range of gain is 0.75~1.246 SUB_CONTRAST_B=00h: contrast gain=0.75 SUB_CONTRAST_B=40h: contrast gain=1 SUB_CONTRAST_B=7Fh: contrast gain=1.246

8.2.5 BRIGHTNESS (14h)

Address	TYPE	D7	D6	D5	D4	D3	D2	D1	D0	Default
14h	W	BRIGHTNESS[7:0]							40h	

Designation	Description
BRIGHTNESS[7:0]	Set RGB brightness level, the range of brightness is -64~+191 BRIGHTNESS=00h: -64 BRIGHTNESS=40h: 0 BRIGHTNESS=FFh: +191

8.2.6 SUB-BRIGHTNESS_R (15h)

Address	TYPE	D7	D6	D5	D4	D3	D2	D1	D0	Default
15h	W	0	SUB_BRIGHTNESS_R[6:0]						40h	

Designation	Description
SUB_BRIGHTNESS_R [6:0]	Set red color sub-brightness level, the range of brightness is -64~+63 SUB_BRIGHTNESS_R=00h: -64 SUB_BRIGHTNESS_R=40h: 0 SUB_BRIGHTNESS_R=7Fh: +63

8.2.7 SUB-BRIGHTNESS_B (16h)

Address	TYPE	D7	D6	D5	D4	D3	D2	D1	D0	Default
16h	W	0	SUB_BRIGHTNESS_B[6:0]							40h

Designation	Description
SUB_BRIGHTNESS_B [6:0]	Set blue color sub-brightness level, the range of brightness is -64~+63 SUB_BRIGHTNESS_B=00h: -64 SUB_BRIGHTNESS_B=40h: 0 SUB_BRIGHTNESS_B=7Fh: +63

8.2.8 H_BLANKING (17h)

Address	TYPE	D7	D6	D5	D4	D3	D2	D1	D0	Default
17h	W	H_BLANKING[7:0]								08h

Designation	Description
H_BLANKING[7:0]	The HSYNC back porch setting of RGB interface

8.2.9 V_BLANKING (18h)

Address	TYPE	D7	D6	D5	D4	D3	D2	D1	D0	Default
18h	W	V_BLANKING[7:0]								10h

Designation	Description
V_BLANKING[7:0]	The VSYNC back porch setting of RGB interface

8.2.10 OTP AUTO DOWNLOAD CONTROL (1Ch)

Address	TYPE	D7	D6	D5	D4	D3	D2	D1	D0	Default
1Ch	W	0	0	0	0	0	AUTODL	0	0	--

Designation	Description
AUTODL	OTP auto-refresh function control AUTODL= 0: disable auto-refresh function AUTODL= 1: enable auto-refresh function

8.3 Command Table2 Register Description

8.3.1 GVDD SETTING (40h)

Address	TYPE	D7	D6	D5	D4	D3	D2	D1	D0	Default
40h	R/W	0	VRHP[6:0]							--

Designation	Description							
VRHP[6:0]	GVDD level setting							
	VRHP[6:0]	GVDD	VRHP[6:0]	GVDD	VRHP[6:0]	GVDD	VRHP[6:0]	GVDD
	10h	6.0000	2Ch	5.6500	48h	5.3000	64h	4.9500
	11h	5.9875	2Dh	5.6375	49h	5.2875	65h	4.9375
	12h	5.9750	2Eh	5.6250	4Ah	5.2750	66h	4.9250
	13h	5.9625	2Fh	5.6125	4Bh	5.2625	67h	4.9125
	14h	5.9500	30h	5.6000	4Ch	5.2500	68h	4.9000
	15h	5.9375	31h	5.5875	4Dh	5.2375	69h	4.8875
	16h	5.9250	32h	5.5750	4Eh	5.2250	6Ah	4.8750
	17h	5.9125	33h	5.5625	4Fh	5.2125	6Bh	4.8625
	18h	5.9000	34h	5.5500	50h	5.2000	6Ch	4.8500
	19h	5.8875	35h	5.5375	51h	5.1875	6Dh	4.8375
	1Ah	5.8750	36h	5.5250	52h	5.1750	6Eh	4.8250
	1Bh	5.8625	37h	5.5125	53h	5.1625	6Fh	4.8125
	1Ch	5.8500	38h	5.5000	54h	5.1500	70h	4.8000
	1Dh	5.8375	39h	5.4875	55h	5.1375	71h	4.7875
	1Eh	5.8250	3Ah	5.4750	56h	5.1250	72h	4.7750
	1Fh	5.8125	3Bh	5.4625	57h	5.1125	73h	4.7625
	20h	5.8000	3Ch	5.4500	58h	5.1000	74h	4.7500
	21h	5.7875	3Dh	5.4375	59h	5.0875	75h	4.7375
	22h	5.7750	3Eh	5.4250	5Ah	5.0750	76h	4.7250
	23h	5.7625	3Fh	5.4125	5Bh	5.0625	77h	4.7125
	24h	5.7500	40h	5.4000	5Ch	5.0500	78h	4.7000
	25h	5.7375	41h	5.3875	5Dh	5.0375	79h	4.6875
	26h	5.7250	42h	5.3750	5Eh	5.0250	7Ah	4.6750
	27h	5.7125	43h	5.3625	5Fh	5.0125	7Bh	4.6625
	28h	5.7000	44h	5.3500	60h	5.0000	7Ch	4.6500
	29h	5.6875	45h	5.3375	61h	4.9875	7Dh	4.6375
2Ah	5.6750	46h	5.3250	62h	4.9750	7Eh	4.6250	
2Bh	5.6625	47h	5.3125	63h	4.9625	7Fh	4.6125	
<i>Note. Do not use register values not listed in the table</i>								

8.3.2 GVCL SETTING (41h)

Address	TYPE	D7	D6	D5	D4	D3	D2	D1	D0	Default
41h	R/W	0	VRHN[6:0]							--

Designation	Description							
VRHN[6:0]	GVCL level setting							
	VRHN[6:0]	GVCL	VRHN[6:0]	GVCL	VRHN[6:0]	GVCL	VRHN[6:0]	GVCL
	10h	-4.4000	2Ch	-4.0500	48h	-3.7000	64h	-3.3500
	11h	-4.3875	2Dh	-4.0375	49h	-3.6875	65h	-3.3375
	12h	-4.3750	2Eh	-4.0250	4Ah	-3.6750	66h	-3.3250
	13h	-4.3625	2Fh	-4.0125	4Bh	-3.6625	67h	-3.3125
	14h	-4.3500	30h	-4.0000	4Ch	-3.6500	68h	-3.3000
	15h	-4.3375	31h	-3.9875	4Dh	-3.6375	69h	-3.2875
	16h	-4.3250	32h	-3.9750	4Eh	-3.6250	6Ah	-3.2750
	17h	-4.3125	33h	-3.9625	4Fh	-3.6125	6Bh	-3.2625
	18h	-4.3000	34h	-3.9500	50h	-3.6000	6Ch	-3.2500
	19h	-4.2875	35h	-3.9375	51h	-3.5875	6Dh	-3.2375
	1Ah	-4.2750	36h	-3.9250	52h	-3.5750	6Eh	-3.2250
	1Bh	-4.2625	37h	-3.9125	53h	-3.5625	6Fh	-3.2125
	1Ch	-4.2500	38h	-3.9000	54h	-3.5500	70h	-3.2000
	1Dh	-4.2375	39h	-3.8875	55h	-3.5375	71h	-3.1875
	1Eh	-4.2250	3Ah	-3.8750	56h	-3.5250	72h	-3.1750
	1Fh	-4.2125	3Bh	-3.8625	57h	-3.5125	73h	-3.1625
	20h	-4.2000	3Ch	-3.8500	58h	-3.5000	74h	-3.1500
	21h	-4.1875	3Dh	-3.8375	59h	-3.4875	75h	-3.1375
	22h	-4.1750	3Eh	-3.8250	5Ah	-3.4750	76h	-3.1250
	23h	-4.1625	3Fh	-3.8125	5Bh	-3.4625	77h	-3.1125
	24h	-4.1500	40h	-3.8000	5Ch	-3.4500	78h	-3.1000
	25h	-4.1375	41h	-3.7875	5Dh	-3.4375	79h	-3.0875
	26h	-4.1250	42h	-3.7750	5Eh	-3.4250	7Ah	-3.0750
	27h	-4.1125	43h	-3.7625	5Fh	-3.4125	7Bh	-3.0625
	28h	-4.1000	44h	-3.7500	60h	-3.4000	7Ch	-3.0500
	29h	-4.0875	45h	-3.7375	61h	-3.3875	7Dh	-3.0375
	2Ah	-4.0750	46h	-3.7250	62h	-3.3750	7Eh	-3.0250
	2Bh	-4.0625	47h	-3.7125	63h	-3.3625	7Fh	-3.0125
<i>Note. Do not use register values not listed in the table</i>								

8.3.3 VGHS, VGL SETTING (45h)

Address	TYPE	D7	D6	D5	D4	D3	D2	D1	D0	Default
45h	R/W	VGL[2:0]			1	VGHS[2:0]			1	--

Designation	Description														
VGL[2:0]	VGL level setting														
	<table border="1"> <thead> <tr> <th>VGL[2:0]</th> <th>VGL (V)</th> </tr> </thead> <tbody> <tr> <td>000</td> <td>-7.5</td> </tr> <tr> <td>001</td> <td>-8.5</td> </tr> <tr> <td>010</td> <td>-9.5</td> </tr> <tr> <td>011</td> <td>-10.5</td> </tr> <tr> <td>100</td> <td>-11</td> </tr> <tr> <td>101</td> <td>-11.5</td> </tr> </tbody> </table>	VGL[2:0]	VGL (V)	000	-7.5	001	-8.5	010	-9.5	011	-10.5	100	-11	101	-11.5
	VGL[2:0]	VGL (V)													
	000	-7.5													
	001	-8.5													
	010	-9.5													
	011	-10.5													
	100	-11													
101	-11.5														
VGHS[2:0]	VGHS level setting														
	<table border="1"> <thead> <tr> <th>VGHS[2:0]</th> <th>VGHS (V)</th> </tr> </thead> <tbody> <tr> <td>000</td> <td>9</td> </tr> <tr> <td>001</td> <td>11</td> </tr> <tr> <td>010</td> <td>13</td> </tr> <tr> <td>011</td> <td>15</td> </tr> <tr> <td>100</td> <td>17</td> </tr> </tbody> </table>	VGHS[2:0]	VGHS (V)	000	9	001	11	010	13	011	15	100	17		
	VGHS[2:0]	VGHS (V)													
	000	9													
	001	11													
	010	13													
011	15														
100	17														

8.4 Gamma Table Register Description

8.4.1 GAMMA SETTING (20h~29h, 30h~39h)

Address	TYPE	D7	D6	D5	D4	D3	D2	D1	D0	Default
20h	R/W	0	RATIO1[1:0]		VRFP0P[4:0]				--	
21h	R/W	0	PFP6[3]	PFP0[3]	VOS0P[4:0]				--	
22h	R/W	PFP0[2:0]			PKP0[4:0]				--	
23h	R/W	PFP1[2:0]			PKP1[4:0]				--	
24h	R/W	PFP2[2:0]			PKP2[4:0]				--	
25h	R/W	PFP3[2:0]			PKP3[4:0]				--	
26h	R/W	PFP4[2:0]			PKP4[4:0]				--	
27h	R/W	PFP5[2:0]			PKP5[4:0]				--	
28h	R/W	PFP6[2:0]			PKP6[4:0]				--	
29h	R/W	0	0	0	PKP7[4:0]				--	
30h	R/W	0	RATIO2[1:0]		VRFP0N[4:0]				--	
31h	R/W	0	PFN6[3]	PFN0[3]	VOS0N[4:0]				--	
32h	R/W	PFN0[2:0]			PKN0[4:0]				--	
33h	R/W	PFN1[2:0]			PKN1[4:0]				--	
34h	R/W	PFN2[2:0]			PKN2[4:0]				--	
35h	R/W	PFN3[2:0]			PKN3[4:0]				--	
36h	R/W	PFN4[2:0]			PKN4[4:0]				--	
37h	R/W	PFN5[2:0]			PKN5[4:0]				--	
38h	R/W	PFN6[2:0]			PKN6[4:0]				--	
39h	R/W	0	0	0	PKN7[4:0]				--	

Designation	Description
PKP0[4:0]	V16 gamma selection
PKN0[4:0]	
PKP1[4:0]	V32 gamma selection
PKN1[4:0]	
PKP2[4:0]	V48 gamma selection
PKN2[4:0]	
PKP3[4:0]	V80 gamma selection
PKN3[4:0]	
PKP4[4:0]	V176 gamma selection
PKN4[4:0]	
PKP5[4:0]	V208 gamma selection
PKN5[4:0]	
PKP6[4:0]	V224 gamma selection
PKN6[4:0]	

PKP7[4:0]	V240 gamma selection
PKN7[4:0]	
VRF0P[4:0]	V8 gamma selection
VRF0N[4:0]	
VOS0P[4:0]	V248 gamma selection
VOS0N[4:0]	
PFP0[3:0]	V12 gamma selection
PFN0[3:0]	
PFP1[2:0]	V64 gamma selection
PFN1[2:0]	
PFP2[2:0]	V104 gamma selection
PFN2[2:0]	
PFP3[2:0]	V128 gamma selection
PFN3[2:0]	
PFP4[2:0]	V152 gamma selection
PFN4[2:0]	
PFP5[2:0]	V192 gamma selection
PFN5[2:0]	
PFP6[3:0]	V244 gamma selection
PFN6[3:0]	
RATIO1[1:0]	V0-V8 gamma ratio selection
RATIO2[1:0]	V248-V255 gamma ratio selection

8.5 OTP Table Register Description

8.5.1 ID1 SETTING (01h)

Address	TYPE	D7	D6	D5	D4	D3	D2	D1	D0	Default	
01h	R/W	0	ID1[6:0]								--

Designation	Description
ID1[6:0]	Built-in OTP for ID1 setting.

8.5.2 ID2 SETTING (02h)

Address	TYPE	D7	D6	D5	D4	D3	D2	D1	D0	Default	
02h	R/W	0	ID2[6:0]								--

Designation	Description
ID2[6:0]	Built-in OTP for ID2 setting.

8.5.3 ID3 SETTING (03h)

Address	TYPE	D7	D6	D5	D4	D3	D2	D1	D0	Default	
03h	R/W	0	ID3[6:0]								--

Designation	Description
ID3[6:0]	Built-in OTP for ID3 setting.

8.5.4 VCOM OFFSET SETTING (05h)

Address	TYPE	D7	D6	D5	D4	D3	D2	D1	D0	Default	
05h	R/W	0	VMF[6:0]								40h

Designation	Description																																																							
VMF[6:0]	VCOM offset setting																																																							
	<table border="1"> <thead> <tr> <th>VMF[6]</th> <th>VMF[5:0]</th> <th>VCOM"</th> <th>GVDD</th> <th>GVCL</th> </tr> </thead> <tbody> <tr> <td>0</td> <td>000000</td> <td>VCOM+64d</td> <td>VRHP[6:0]+64d</td> <td>VRHN[6:0]+64d</td> </tr> <tr> <td>0</td> <td>000001</td> <td>VCOM+63d</td> <td>VRHP[6:0]+63d</td> <td>VRHN[6:0]+63d</td> </tr> <tr> <td>0</td> <td>000010</td> <td>VCOM+62d</td> <td>VRHP[6:0]+62d</td> <td>VRHN[6:0]+62d</td> </tr> <tr> <td>0</td> <td> </td> <td> </td> <td> </td> <td> </td> </tr> <tr> <td>0</td> <td>111110</td> <td>VCOM+2d</td> <td>VRHP[6:0]+2d</td> <td>VRHN[6:0]+2d</td> </tr> <tr> <td>0</td> <td>111111</td> <td>VCOM+1d</td> <td>VRHP[6:0]+1d</td> <td>VRHN[6:0]+1d</td> </tr> <tr> <td>1</td> <td>000000</td> <td>VCOM+0d</td> <td>VRHP[6:0]</td> <td>VRHN[6:0]</td> </tr> <tr> <td>1</td> <td>000001</td> <td>VCOM-1d</td> <td>VRHP[6:0]-1d</td> <td>VRHN[6:0]-1d</td> </tr> <tr> <td>1</td> <td>000010</td> <td>VCOM-2d</td> <td>VRHP[6:0]-2d</td> <td>VRHN[6:0]-2d</td> </tr> <tr> <td>1</td> <td> </td> <td> </td> <td> </td> <td> </td> </tr> </tbody> </table>	VMF[6]	VMF[5:0]	VCOM"	GVDD	GVCL	0	000000	VCOM+64d	VRHP[6:0]+64d	VRHN[6:0]+64d	0	000001	VCOM+63d	VRHP[6:0]+63d	VRHN[6:0]+63d	0	000010	VCOM+62d	VRHP[6:0]+62d	VRHN[6:0]+62d	0					0	111110	VCOM+2d	VRHP[6:0]+2d	VRHN[6:0]+2d	0	111111	VCOM+1d	VRHP[6:0]+1d	VRHN[6:0]+1d	1	000000	VCOM+0d	VRHP[6:0]	VRHN[6:0]	1	000001	VCOM-1d	VRHP[6:0]-1d	VRHN[6:0]-1d	1	000010	VCOM-2d	VRHP[6:0]-2d	VRHN[6:0]-2d	1				
	VMF[6]	VMF[5:0]	VCOM"	GVDD	GVCL																																																			
	0	000000	VCOM+64d	VRHP[6:0]+64d	VRHN[6:0]+64d																																																			
	0	000001	VCOM+63d	VRHP[6:0]+63d	VRHN[6:0]+63d																																																			
	0	000010	VCOM+62d	VRHP[6:0]+62d	VRHN[6:0]+62d																																																			
	0																																																							
	0	111110	VCOM+2d	VRHP[6:0]+2d	VRHN[6:0]+2d																																																			
	0	111111	VCOM+1d	VRHP[6:0]+1d	VRHN[6:0]+1d																																																			
	1	000000	VCOM+0d	VRHP[6:0]	VRHN[6:0]																																																			
	1	000001	VCOM-1d	VRHP[6:0]-1d	VRHN[6:0]-1d																																																			
1	000010	VCOM-2d	VRHP[6:0]-2d	VRHN[6:0]-2d																																																				
1																																																								

1	111110	VCOM-62d	VRHP[6:0]-62d	VRHN[6:0]-62d
1	111111	VCOM-63d	VRHP[6:0]-63d	VRHN[6:0]-63d

Note: 1.d=12.5mV

- Adjustable VCOM offset (OTP) can be used to compensate feedthrough tolerance and its limitation couldn't exceed the maximum voltage range of GVDD and GVCL.
- $VCOM'' \leq GVDD - Vop = GVCL + Vop$
Vop is the operation voltage of liquid crystal.

The diagram illustrates the calculation of the final VCOM value. It shows 'VCOM (internal VCOM)' entering a summing junction (a circle with a plus sign). Another input to the summing junction is 'VMF[6:0]', which is derived from an 'OTP' (One-Time Programmable) block. The output of the summing junction is labeled 'VCOM'' (VGSP)'.

8.5.5 OTP FUNCTION CONTROL (60h)

Address	TYPE	D7	D6	D5	D4	D3	D2	D1	D0	Default
60h	W	0	1	0	0	0	1	OTPEN	0	44h

Designation	Description
OTPEN	OTP programming function control OTPEN = 0: disable OTP programming function OTPEN = 1: enable OTP programming function

8.5.6 OTP ACKNOWLEDGEMENT CONTROL (65h)

Address	TYPE	D7	D6	D5	D4	D3	D2	D1	D0	Default
65h	W	OTPACK[7:0]								00h

Designation	Description										
OTPACK[7:0]	OTP active selection										
	<table border="1"> <thead> <tr> <th>OTPACK[7:0]</th> <th>Description</th> </tr> </thead> <tbody> <tr> <td>31h</td> <td>ID1 program</td> </tr> <tr> <td>32h</td> <td>ID2 program</td> </tr> <tr> <td>33h</td> <td>ID3 program</td> </tr> <tr> <td>3Ah</td> <td>VCOM offset program</td> </tr> </tbody> </table>	OTPACK[7:0]	Description	31h	ID1 program	32h	ID2 program	33h	ID3 program	3Ah	VCOM offset program
	OTPACK[7:0]	Description									
	31h	ID1 program									
	32h	ID2 program									
33h	ID3 program										
3Ah	VCOM offset program										

8.5.7 ID1 PROGRAM TIMES (68h)

Address	TYPE	D7	D6	D5	D4	D3	D2	D1	D0	Default
68h	R	0	0	0	0	0	ID1 OTP TIME[2:0]			--

Designation	Description
ID1 OTP TIME[2:0]	Read ID1 remaining programmable times

8.5.8 ID2 PROGRAM TIMES (69h)

Address	TYPE	D7	D6	D5	D4	D3	D2	D1	D0	Default
69h	R	0	0	0	0	0	ID2 OTP TIME[2:0]			--

Designation	Description
ID2 OTP TIME[2:0]	Read ID2 remaining programmable times

8.5.9 ID3 PROGRAM TIMES (6Ah)

Address	TYPE	D7	D6	D5	D4	D3	D2	D1	D0	Default
6Ah	R	0	0	0	0	0	ID3 OTP TIME[2:0]			--

Designation	Description
ID3 OTP TIME[2:0]	Read ID3 remaining programmable times

8.5.10 VCOM OFFEST PROGRAM TIMES (6Ch)

Address	TYPE	D7	D6	D5	D4	D3	D2	D1	D0	Default
6Ch	R	0	0	0	0	0	VMF OTP TIME[2:0]			--

Designation	Description
VMF OTP TIME[2:0]	Read VMF remaining programmable times

9. ELECTRICAL SPECIFICATIONS

9.1 Absolute Maximum Ratings

Item	Symbol	Rating	Unit
Power Supply Voltage	VDD	- 0.3 ~ +4.0	V
IO Supply Voltage	VDDI	- 0.3 ~ +4.0	V
Charge Pump Supply Voltage	PVDD	- 0.3 ~ +4.0	V
Logic Input Voltage Range	VIN	-0.3 ~ VDDI + 0.3	V
Logic Output Voltage Range	VOUT	-0.3 ~ VDDI + 0.3	V
Operating Temperature Range	TOPR	-30 ~ +85	°C
Storage Temperature Range	TSTG	-40 ~ +125	°C

Note:

1. That the stress exceeds the Limiting Value listed above it may cause the driver IC permanent damage. These values are for stress only. IC should be operated under the DC/AC Characteristic conditions for normal operation. If these conditions are not met, IC operation may be error and the reliability may be deteriorated.
2. Parameters are valid over operating temperature range unless otherwise specified. All voltages are with respect to VSS unless otherwise noted.
3. Insure the voltage levels of VDDI, VDD, PVDD always matches the correct relation:
 $3.1V \leq VDDI \leq VDD = PVDD \leq 3.6V$
4. VIN should be less than or equal to 3.6V. (VIN ≤ 3.6V)
5. Panel display quality depends on panel loading, and it may have the different performance at low/high temperature.
6. When the backlight LED is turned on which is the heat generation leads to the increasing temperature of the LCD module.
 In order to protect the LCD driver IC against thermal effect, we advise that the position of backlight LED should not be close to the driver IC. The edge-lit type LED is recommended.

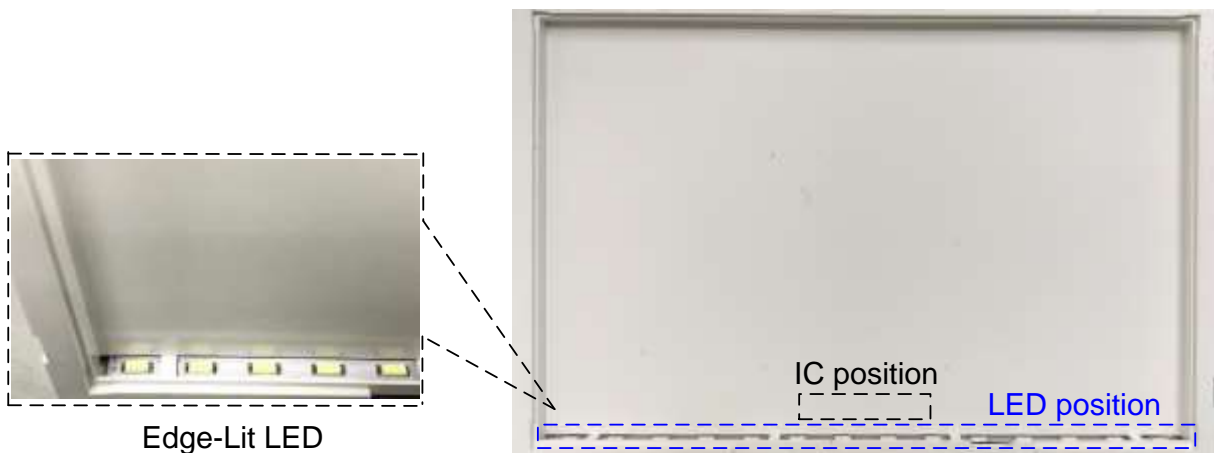

9.2 DC Characteristics

DC Electrical Characteristics (PVDD=VDD=VDDI= 3.3V, AGND= 0V, TA=25°C, Bare Chip)

9.2.1 Recommended Operating Range

DC Electrical Characteristics (PVDD=VDD=VDDI= 3.3V, AGND= 0V, TA=25°C, Bare Chip)

Item	Symbol	Min.	Typ.	Max.	Unit	Conditions
IO Supply Voltage	VDDI	3.1	3.3	3.6	V	
Analog Supply Voltage	VDD	3.1	3.3	3.6	V	
Charge Pump Supply Voltage	PVDD	3.1	3.3	3.6	V	

9.2.2 DC Characteristics for Digital Circuit

DC Electrical Characteristics (PVDD=VDD=VDDI= 3.3V, AGND= 0V, TA=25°C, Bare Chip)

Item	Symbol	Min.	Typ.	Max.	Unit	Conditions
Logic-High Input Voltage	Vih	0.7VDDI	-	VDDI	V	
Logic-Low Input Voltage	Vil	DGND	-	0.3VDDI	V	
Logic-High Output Voltage	Voh	VDDI-0.4	-	VDDI	V	
Logic-Low Output Voltage	Vol	DGND	-	DGND+0.4	V	

9.2.3 DC Characteristics for Analog Circuit

DC Electrical Characteristics (PVDD=VDD=VDDI= 3.3V, AGND= 0V, TA=25°C, Bare Chip)

Item	Symbol	Min.	Typ.	Max.	Unit	Conditions
Positive High-Voltage Power	VGHS	9	15	17	V	No Load@ FR=60Hz
Negative High-Voltage Power	VGL	-11.5	-10.5	-7	V	
Output Voltage Deviation	Vod	-	±40	±50	mV	
Standby Current	Isc	-	-	50	uA	
Operation Current	Ioc	-	40	-	mA	

9.2.4 DC Characteristics for LVDS Receiver Circuit

Single End Signals

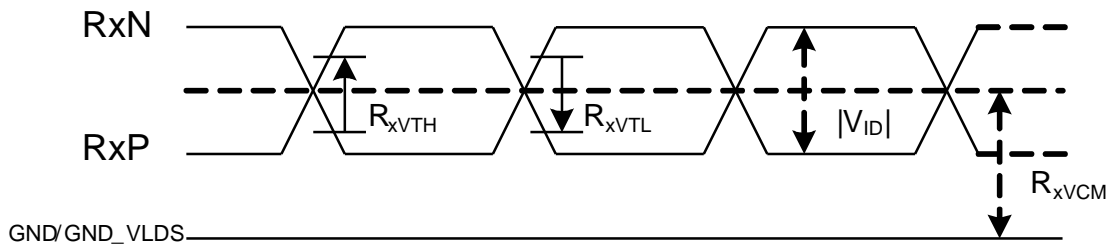

Differential Signals

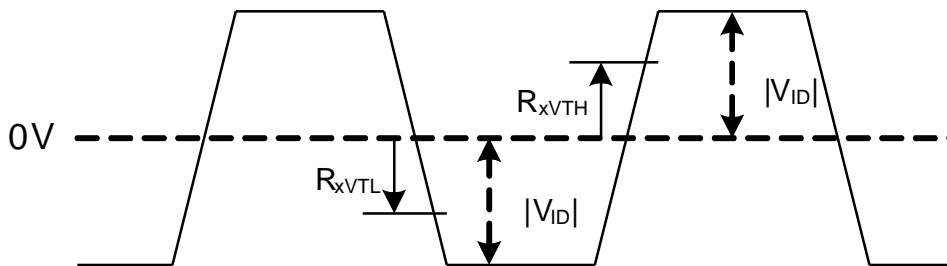

DC Electrical Characteristics (PVDD=VDD=VDDI= 3.3V, AGND= 0V, TA=25°C, Bare Chip)

Item	Symbol	Min.	Typ.	Max.	Unit	Conditions
Differential Input High Threshold Voltage	R_{xVTH}	-	-	0.1	V	$R_{xVCM} = 1.2V$
Differential Input Low Threshold Voltage	R_{xVTL}	-0.1	-	-	V	
Input Voltage Range (Singed-End)	R_{xVIN}	0	-	VDD-1.0	V	
Differential Input Common Mode Voltage	R_{xVCM}	$ V_{ID} /2$	-	$2.4- V_{ID} /2$	V	
Differential Input Voltage	$ V_{ID} $	0.2	-	0.6	V	
Differential Input Leakage Current	$R_{V_{xIz}}$	-10	-	10	uA	
LVDS Digital Operating Current	I_{VDD_LVDS}	-	10	15	mA	
LVDS Digital Stand-by Current	I_{STBD_LVDS}	-	10	50	uA	
Differential Input Termination Resistance	R_{ID}	90	100	110	Ω	

9.3 AC Characteristics

AC Electrical Characteristics (PVDD=VDD=VDDI= 3.3V, AGND= 0V, TA=25°C, Bare Chip)

9.3.1 System Operation AC Characteristics

DC Electrical Characteristics (PVDD=VDD=VDDI= 3.3V, AGND= 0V, TA=25°C, Bare Chip)

Item	Symbol	Min.	Typ.	Max.	Unit	Conditions
VDD Power Source Slew Time	TPOR	-	-	20	ms	From 0V to 99% VDD
GRB Pulse Width	tRSTW	10	50	-	us	R=10Kohm, C=1uF
SD Output Stable Time	Tst	-	-	12	us	Output settled within +20mV Loading = 6.8k+28.2pF.
GD Output Rise and Fall Time	Tgst	-	-	6	us	Output settled (5%~95%), Loading = 4.7k+29.8pF

9.3.2 System Bus Timing for 3-Wire SPI Interface

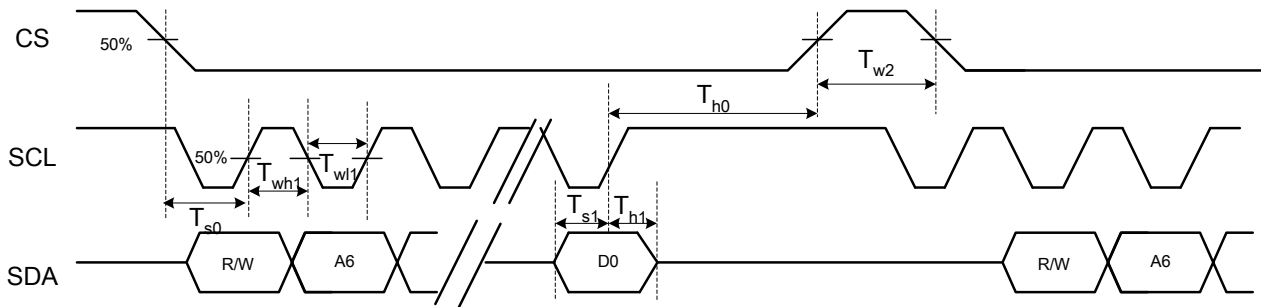

DC Electrical Characteristics (PVDD=VDD=VDDI= 3.3V, AGND= 0V, TA=25°C, Bare Chip)

Item	Symbol	Min.	Typ.	Max.	Unit	Conditions
CS Input Setup Time	Ts0	50	-	-	ns	
Serial Data Input Setup Time	Ts1	50	-	-	ns	
CS Input Hold Time	Th0	50	-	-	ns	
Serial Data Input Hold Time	Th1	50	-	-	ns	
SCL Write Pulse High Width	Twh1	50	-	2000	ns	
SCL Write Pulse Low Width	Twl1	50	-	2000	ns	
SCL Read Pulse High Width	Trh1	300	-	2000	ns	
SCL Read Pulse Low Width	Trl1	300	-	2000	ns	
CS Pulse High Width	Tw2	400	-	-	ns	

9.3.3 System Bus Timing for RGB Interface

DCLK Neagive Polarity (DCLKPOL="H")

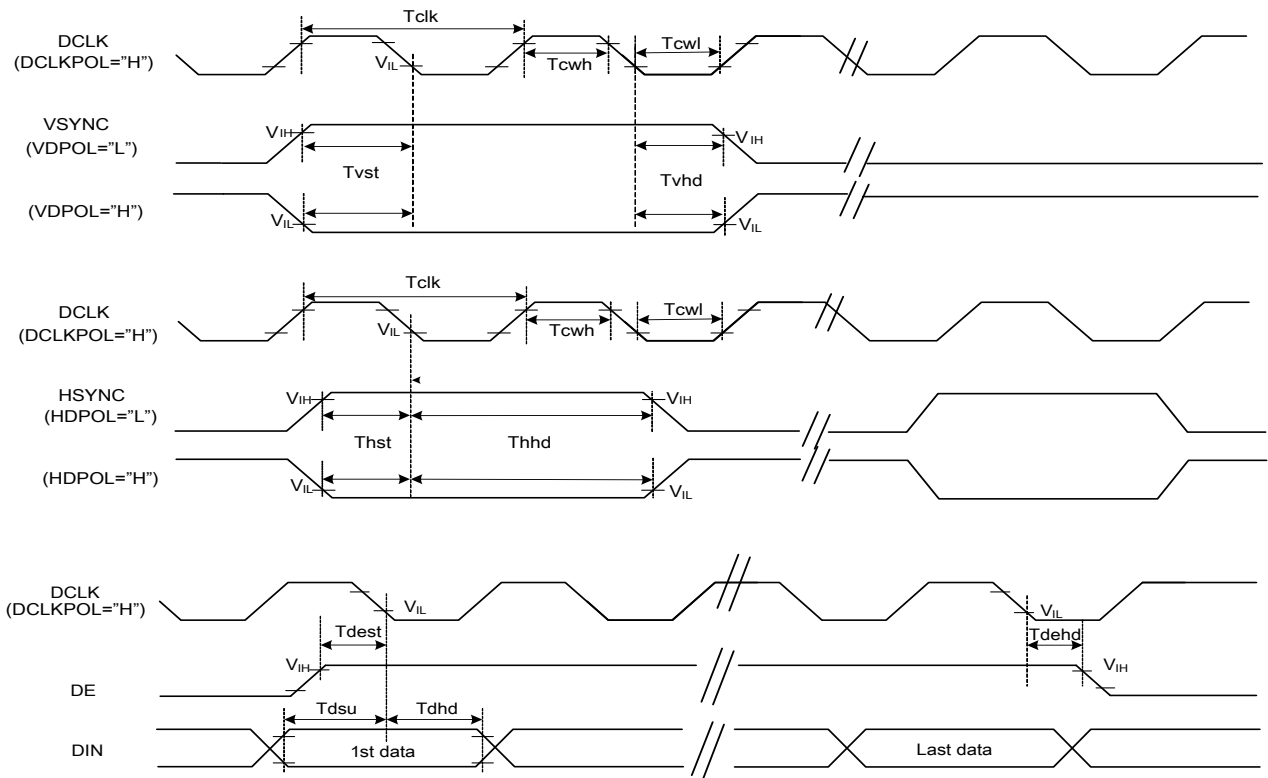

DCLK Positive Polarity (DCLKPOL="L")

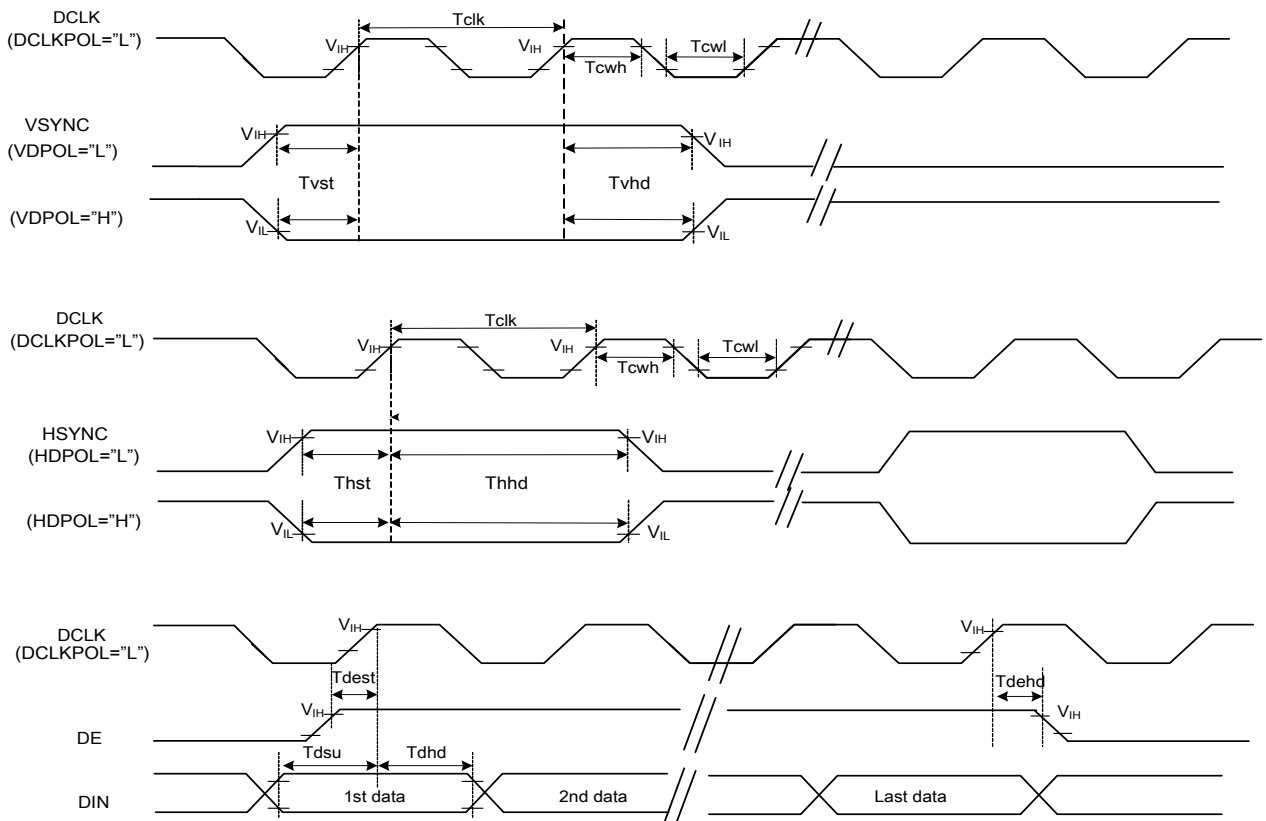

DC Electrical Characteristics (PVDD=VDD=VDDI= 3.3V, AGND= 0V, TA=25°C, Bare Chip)

Item	Symbol	Min.	Typ.	Max.	Unit	Conditions
CLK Pulse Duty	Tcw	40	50	60	%	
VSYNC Setup Time	Tvst	10	-	-	ns	
VSYNC Hold Time	Tvhd	10	-	-	ns	
HSYNC Setup Time	Thst	10	-	-	ns	
HSYNC Hold Time	Thhd	10	-	-	ns	
Data Setup Time	Tdsu	10	-	-	ns	
Data Hold Time	Tdhd	10	-	-	ns	
DE Setup Time	Tdest	10	-	-	ns	
DE Hold Time	Tdehd	10	-	-	ns	

9.3.4 Reset timing

Setting GRB pin to "L" (hardware reset) can initialize internal function. Initialized by GRB pin is essential before operating. There are two suggestions for hardware reset connection.

(1) The GRB pin with external RC circuit.

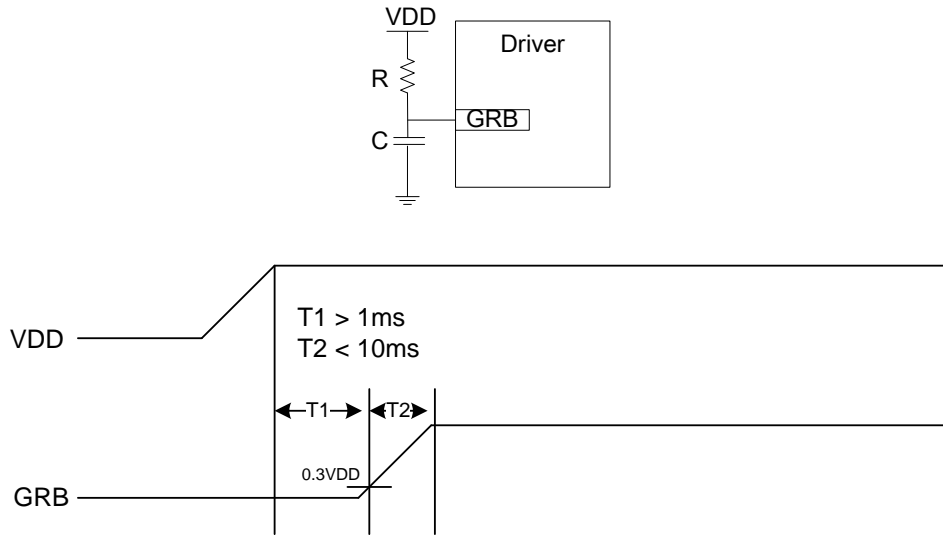

(2) The GRB pin controlled by MCU.

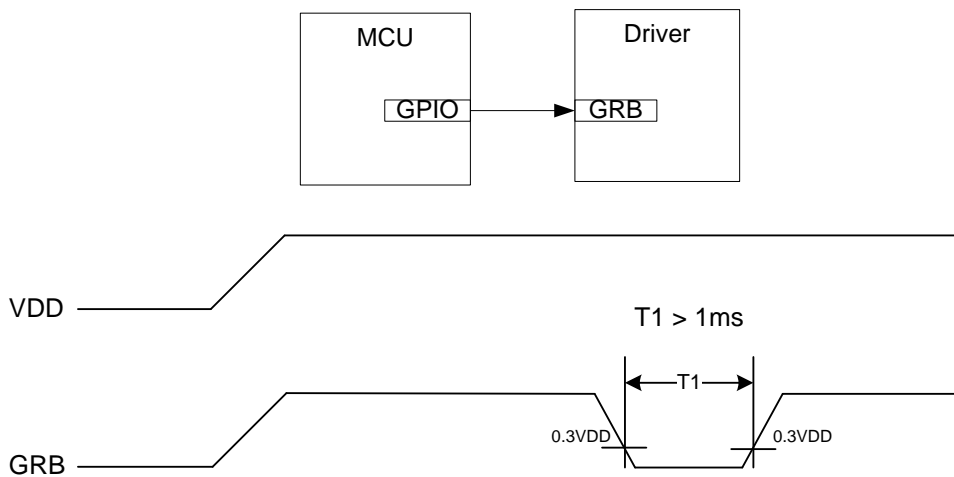

10. APPLICATION CIRCUIT

10.1 1 Power Mode

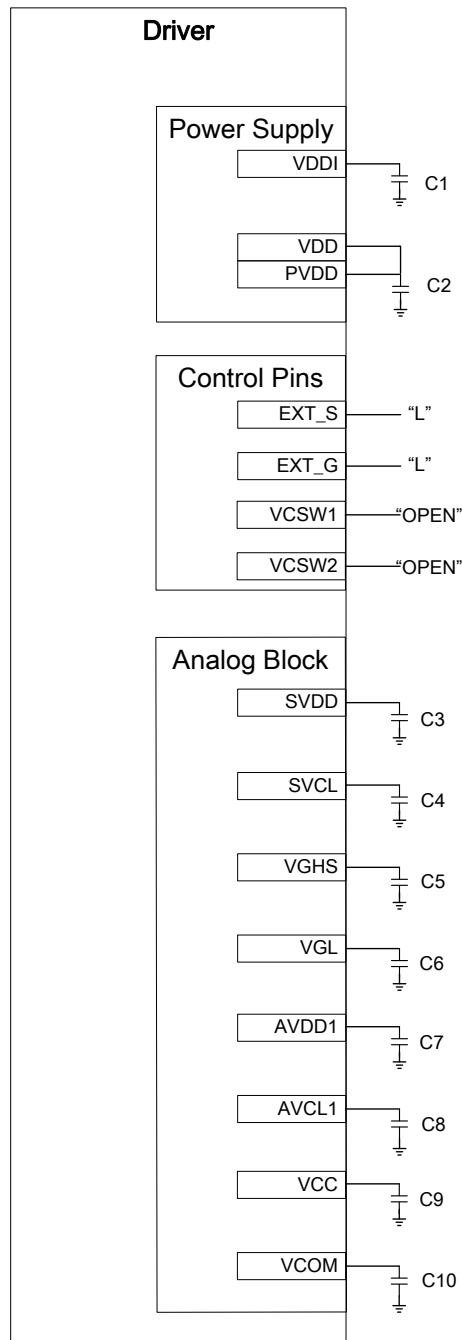

10.1.1 Input Voltage

Pin Name	Voltage range	Note
VDDI	3.1~3.6V	
VDD	3.1~3.6V	
PVDD	3.1~3.6V	

10.1.2 External component

Pin Name	Symbol	Capacitance (uF)	Voltage Proof (V)	Note
VDDI	C1	2.2~4.7	6	
VDD/ PVDD	C2	2.2~4.7	6	
SVDD	C3	2.2~4.7	10	
SVCL	C4	2.2~4.7	10	
VGHS	C5	2.2~4.7	25	
VGL	C6	2.2~4.7	25	
AVDD1	C7	2.2~4.7	10	
AVCL1	C8	2.2~4.7	10	
VCC	C9	2.2~4.7	6	
VCOM	C10	2.2~4.7	6	

Note: 1. Capacitor C1 must be added to VDDI when using LVDS interface.

2. Capacitor C10 is used when feedthrough voltage > 1.2V.

3. Capacitance value depends on panel loading. The recommended default value is 2.2uF.

10.2 3 Power Mode with Charge Pump Controller

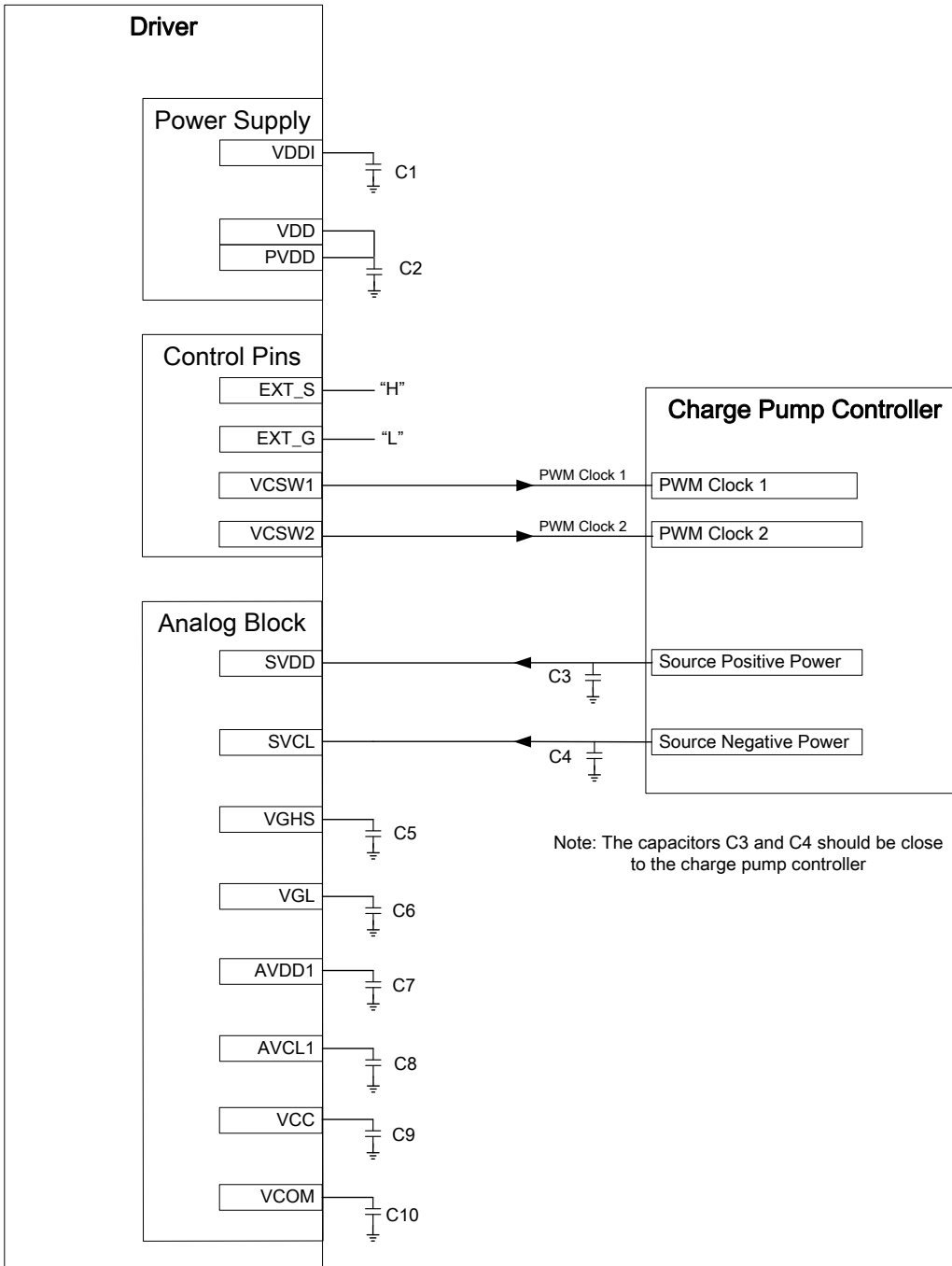

10.2.1 Input Voltage

Pin Name	Voltage range(V)	Note
VDDI	3.1~3.6	
VDD	3.1~3.6	
PVDD	3.1~3.6	
SVDD	6.2~6.6	External power supply by Charge Pump Controller
SVCL	-6.2~-6.6	External power supply by Charge Pump Controller

10.2.2 External component

Symbol	Capacitance (uF)	Voltage Proof (V)	Note
C1	2.2~4.7	6	
C2	2.2~4.7	6	
C3	2.2~4.7	10	
C4	2.2~4.7	10	
C5	2.2~4.7	25	
C6	2.2~4.7	25	
C7	2.2~4.7	10	
C8	2.2~4.7	10	
C9	2.2~4.7	6	
C10	2.2~4.7	6	

Note: 1. Capacitor C1 must be added to VDDI when using LVDS interface.

2. Capacitor C10 is used when feedthrough voltage > 1.2V.

3. Capacitance value depends on panel loading. The recommended default value is 2.2uF.

10.3 3 Power Mode with External Power Supply

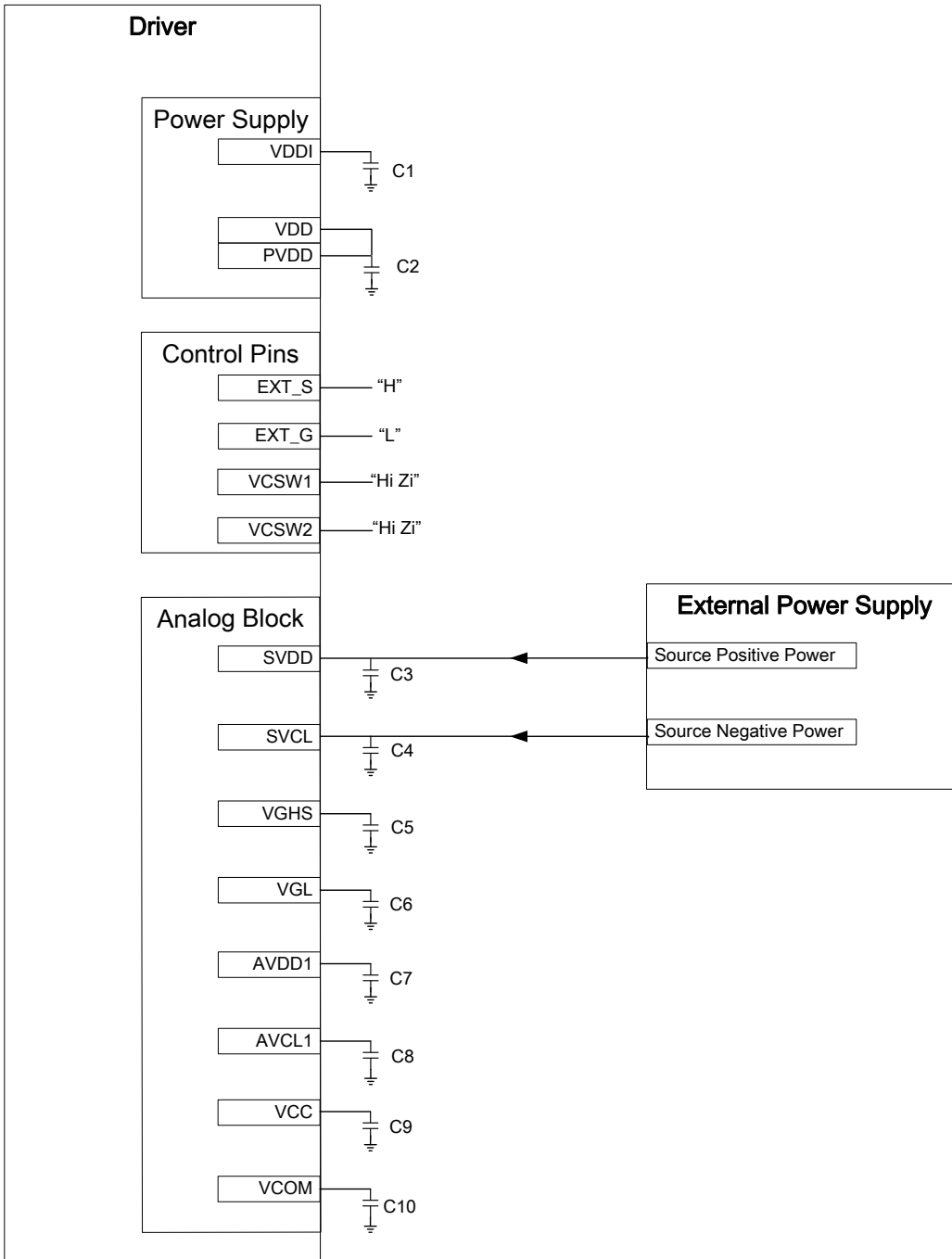

10.3.1 Input Voltage

Pin Name	Voltage range(V)	Note
VDDI	3.1~3.6	
VDD	3.1~3.6	
PVDD	3.1~3.6	
SVDD	6.2~6.6	External power supply
SVCL	-6.2~-6.6	External power supply

10.3.2 External component

Symbol	Capacitance (uF)	Voltage Proof (V)	Note
C1	2.2~4.7	6	
C2	2.2~4.7	6	
C3	2.2~4.7	10	
C4	2.2~4.7	10	
C5	2.2~4.7	25	
C6	2.2~4.7	25	
C7	2.2~4.7	10	
C8	2.2~4.7	10	
C9	2.2~4.7	6	
C10	2.2~4.7	6	

Note: 1. Capacitor C1 must be added to VDDI when using LVDS interface.

2. Capacitor C10 is used when feedthrough voltage > 1.2V.

3. Capacitance value depends on panel loading. The recommended default value is 2.2uF.

10.4 Input Color Format Application Circuit

10.4.1 Pin Assignment for RGB Interface

Pin		Parallel RGB		
		888	666	565
VSYNC	SYNC Mode	VSYNC	VSYNC	VSYNC
	DE Mode	x	x	x
	SYNC DE Mode	VSYNC	VSYNC	VSYNC
HSYNC	SYNC Mode	HSYNC	HSYNC	HSYNC
	DE Mode	x	x	x
	SYNC DE Mode	HSYNC	HSYNC	HSYNC
DE	SYNC Mode	x	x	x
	DE Mode	DE	DE	DE
	SYNC DE Mode	DE	DE	DE
DCLK		DCLK	DCLK	DCLK
DR0	R0	x	x	
DR1	R1	x	x	
DR2	R2	R2	x	
DR3	R3	R3	R3	
DR4	R4	R4	R4	
DR5	R5	R5	R5	
DR6	R6	R6	R6	
DR7	R7	R7	R7	
DG0	G0	x	x	
DG1	G1	x	x	
DG2	G2	G2	G2	
DG3	G3	G3	G3	
DG4	G4	G4	G4	
DG5	G5	G5	G5	
DG6	G6	G6	G6	
DG7	G7	G7	G7	
DB0	B0	x	x	
DB1	B1	x	x	
DB2	B2	B2	x	
DB3	B3	B3	B3	
DB4	B4	B4	B4	
DB5	B5	B5	B5	
DB6	B6	B6	B6	
DB7	B7	B7	B7	

10.4.2 Data Format

Parallel RGB888					
Pin	1 st Data	2 nd Data	3 rd Data	...	N th Data
DR0	1'R0	2'R0	3'R0	...	N'R0
DR1	1'R1	2'R1	3'R1	...	N'R1
DR2	1'R2	2'R2	3'R2	...	N'R2
DR3	1'R3	2'R3	3'R3	...	N'R3
DR4	1'R4	2'R4	3'R4	...	N'R4
DR5	1'R5	2'R5	3'R5	...	N'R5
DR6	1'R6	2'R6	3'R6	...	N'R6
DR7	1'R7	2'R7	3'R7	...	N'R7
DG0	1'G0	2'G0	3'G0	...	N'G0
DG1	1'G1	2'G1	3'G1	...	N'G1
DG2	1'G2	2'G2	3'G2	...	N'G2
DG3	1'G3	2'G3	3'G3	...	N'G3
DG4	1'G4	2'G4	3'G4	...	N'G4
DG5	1'G5	2'G5	3'G5	...	N'G5
DG6	1'G6	2'G6	3'G6	...	N'G6
DG7	1'G7	2'G7	3'G7	...	N'G7
DB0	1'B0	2'B0	3'B0	...	N'B0
DB1	1'B1	2'B1	3'B1	...	N'B1
DB2	1'B2	2'B2	3'B2	...	N'B2
DB3	1'B3	2'B3	3'B3	...	N'B3
DB4	1'B4	2'B4	3'B4	...	N'B4
DB5	1'B5	2'B5	3'B5	...	N'B5
DB6	1'B6	2'B6	3'B6	...	N'B6
DB7	1'B7	2'B7	3'B7	...	N'B7

Parallel RGB666					
Pin	1 st Data	2 nd Data	3 rd Data	...	N th Data
DR0	x	x	x	...	x
DR1	x	x	x	...	x
DR2	1'R0	2'R0	3'R0	...	N'R0
DR3	1'R1	2'R1	3'R1	...	N'R1
DR4	1'R2	2'R2	3'R2	...	N'R2
DR5	1'R3	2'R3	3'R3	...	N'R3
DR6	1'R4	2'R4	3'R4	...	N'R4
DR7	1'R5	2'R5	3'R5	...	N'R5
DG0	x	x	x	...	x
DG1	x	x	x	...	x
DG2	1'G0	2'G0	3'G0	...	N'G0
DG3	1'G1	2'G1	3'G1	...	N'G1
DG4	1'G2	2'G2	3'G2	...	N'G2
DG5	1'G3	2'G3	3'G3	...	N'G3
DG6	1'G4	2'G4	3'G4	...	N'G4
DG7	1'G5	2'G5	3'G5	...	N'G5
DB0	x	x	x	...	x
DB1	x	x	x	...	x
DB2	1'B0	2'B0	3'B0	...	N'B0
DB3	1'B1	2'B1	3'B1	...	N'B1
DB4	1'B2	2'B2	3'B2	...	N'B2
DB5	1'B3	2'B3	3'B3	...	N'B3
DB6	1'B4	2'B4	3'B4	...	N'B4
DB7	1'B5	2'B5	3'B5	...	N'B5

Parallel RGB565					
Pin	1 st Data	2 nd Data	3 rd Data	...	N th Data
DR0	x	x	x	...	x
DR1	x	x	x	...	x
DR2	x	x	x	...	x
DR3	1'R0	2'R0	3'R0	...	N'R0
DR4	1'R1	2'R1	3'R1	...	N'R1
DR5	1'R2	2'R2	3'R2	...	N'R2
DR6	1'R3	2'R3	3'R3	...	N'R3
DR7	1'R4	2'R4	3'R4	...	N'R4
DG0	x	x	x	...	x
DG1	x	x	x	...	x
DG2	1'G0	2'G0	3'G0	...	N'G0
DG3	1'G1	2'G1	3'G1	...	N'G1
DG4	1'G2	2'G2	3'G2	...	N'G2
DG5	1'G3	2'G3	3'G3	...	N'G3
DG6	1'G4	2'G4	3'G4	...	N'G4
DG7	1'G5	2'G5	3'G5	...	N'G5
DB0	x	x	x	...	x
DB1	x	x	x	...	x
DB2	x	x	x	...	x
DB3	1'B0	2'B0	3'B0	...	N'B0
DB4	1'B1	2'B1	3'B1	...	N'B1
DB5	1'B2	2'B2	3'B2	...	N'B2
DB6	1'B3	2'B3	3'B3	...	N'B3
DB7	1'B4	2'B4	3'B4	...	N'B4

10.4.3 16.7M (R G B, 8 8 8) INPUT COLOR FORMAT

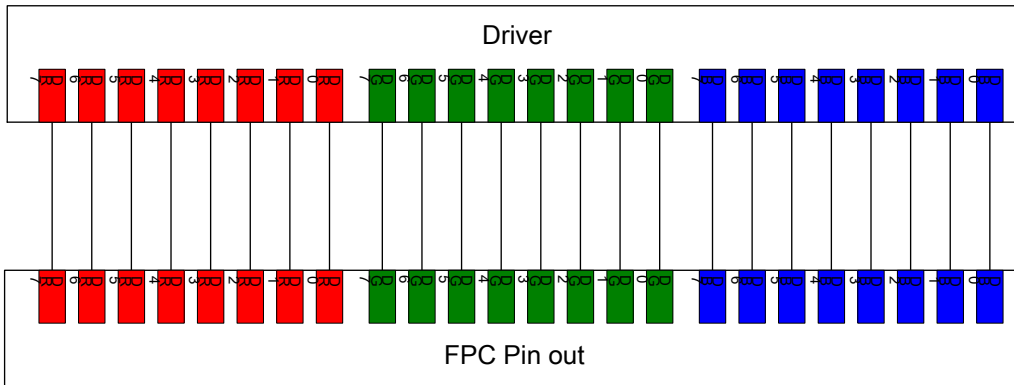

10.4.4 262K (R G B, 6 6 6) INPUT COLOR FORMAT

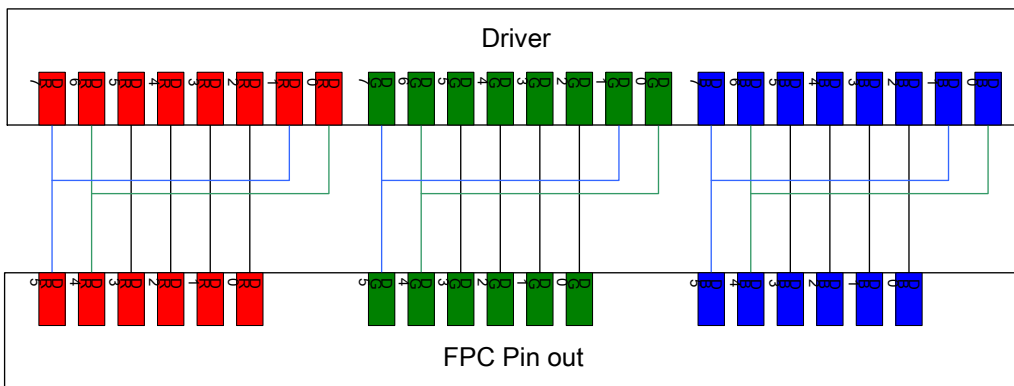

10.4.5 65K (R G B, 5 6 5) INPUT COLOR FORMAT

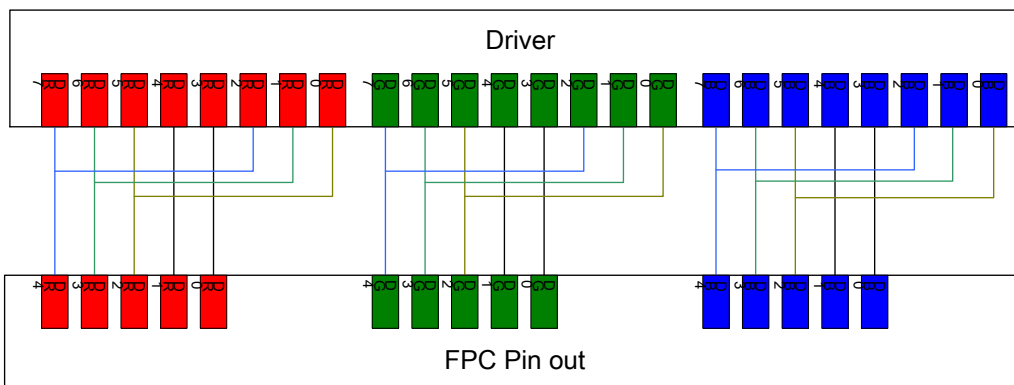

11. POWER ON/OFF SEQUENCE

11.1 Power On Sequence

11.1.1 1 Power Mode

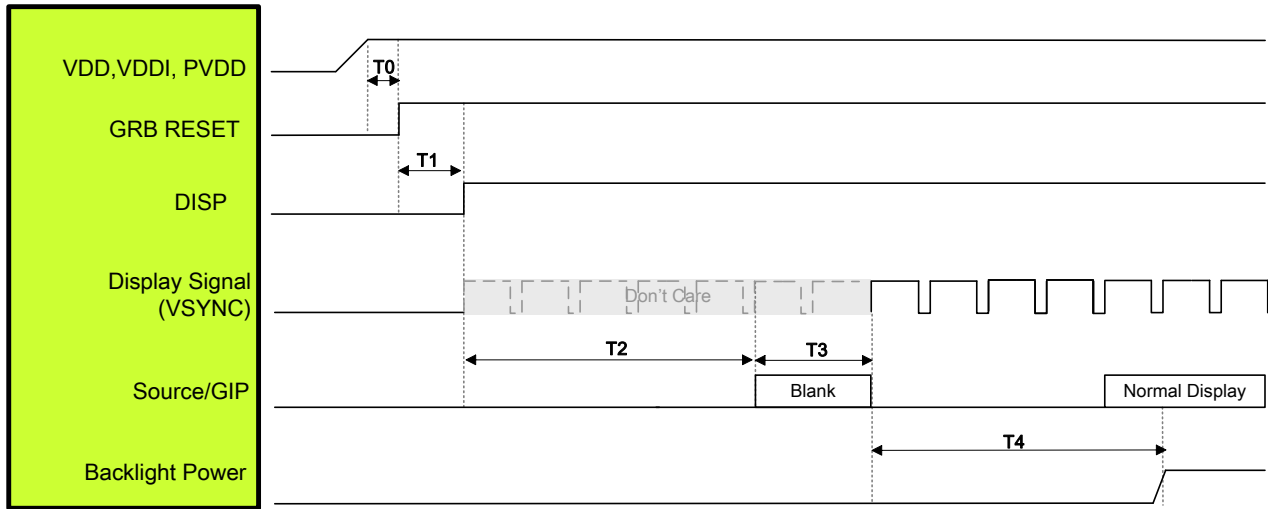

Symbol	Description	Time	Unit
T0	System power stability to GRB RESET signal	≥ 1	ms
T1	GRB RESET= "High" to DISP="High"	≥ 10	ms
T2	DISP="High" to Source/GIP scan blank	85	ms
T3	IC scan blanking signal	≥ 33	ms
T4	Display signal input to Backlight power on (base on Display Signal Frame Rate 60Hz)	≥ 100	ms

Note: 1. When DISP pull "H" or "L", IC will execute the internal power on or power off procedures. Please be careful about the timing of DISP and do not interrupt it during power on or power off procedure, otherwise unexpected errors will occur.

2. RGB interface Display signal: DCLK; VSYNC; HSYNC; DE; DR[7:0]; DG[7:0]; DB[7:0].

3. LVDS interface Display signal: DCLK P/N; RX[3:0] P/N

11.1.2.3 Power Mode with Charge Pump Controller

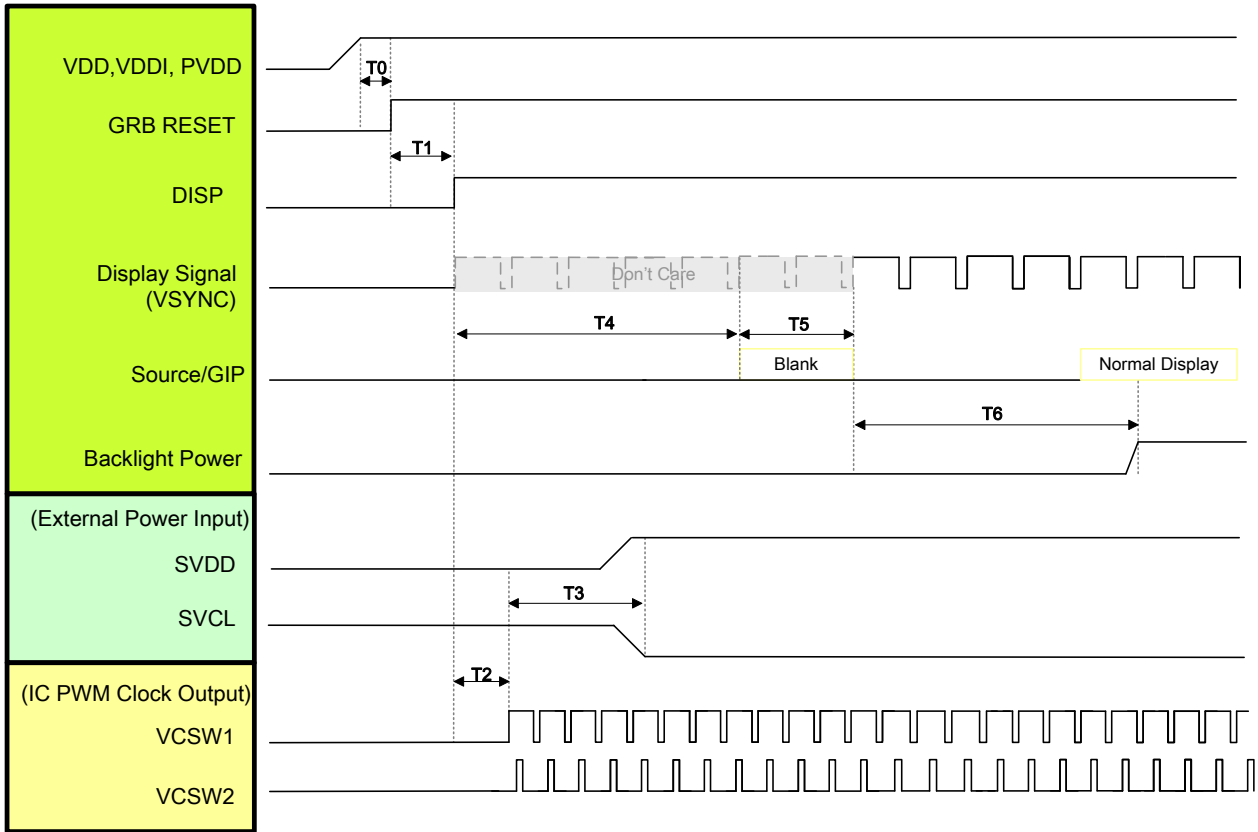

Symbol	Description	Time	Unit
T0	System power stability to GRB RESET signal	≥1	ms
T1	GRB RESET= “High” to DISP= “High”	≥10	ms
T2	DISP=“High” to IC output PWM clock	1	ms
T3	PWM clock input to SVDD/SVCL stability	≤50	ms
T4	DISP=“High” to Source/GIP scan blank	85	ms
T5	IC scan blanking signal	≥33	ms
T6	Display Signal input to Backlight power on (base on Display Signal Frame Rate 60Hz)	≥100	ms

Note: 1. When DISP pull “H” or “L”, IC will execute the internal power on or power off procedures .Please be careful about the timing of DISP and do not interrupt it during power on or power off procedure, otherwise unexpected errors will occur.

2. RGB interface Display signal: DCLK; VSYNC; HSYNC; DE; DR[7:0]; DG[7:0]; DB[7:0].

3. LVDS interface Display signal: DCLK P/N; RX[3:0] P/N.

11.1.3 3 Power Mode with External Power Supply

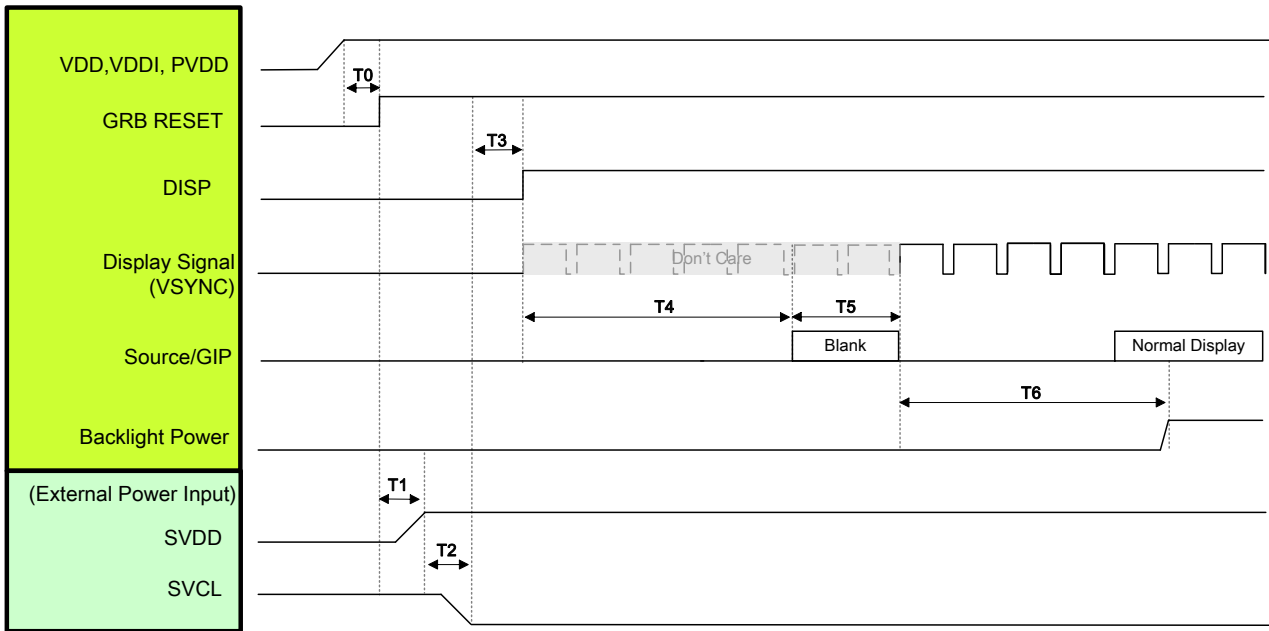

Symbol	Description	Time	Unit
T0	System power stability to GRB RESET signal	≥1	ms
T1	GRB RESET= “High” to SVDD input	≥10	ms
T2	SVDD input to SVCL input	≥1	ms
T3	SVCL input to DISP=“High”	≥1	ms
T4	DISP=“High” to Source/GIP scan blank	85	ms
T5	IC scan blanking signal	≥33	ms
T6	Display Signal input to Backlight power on (base on Display Signal Frame Rate 60Hz)	≥100	ms

Note: 1. When DISP pull “H” or “L”, IC will execute the internal power on or power off procedures .Please be careful about the timing of DISP and do not interrupt it during power on or power off procedure, otherwise unexpected errors will occur.

2. RGB interface Display signal: DCLK; VSYNC; HSYNC; DE; DR[7:0]; DG[7:0]; DB[7:0].

3. LVDS interface Display signal: DCLK P/N; RX[3:0] P/N.

11.2 Power Off Sequence

11.2.1 1 Power Mode

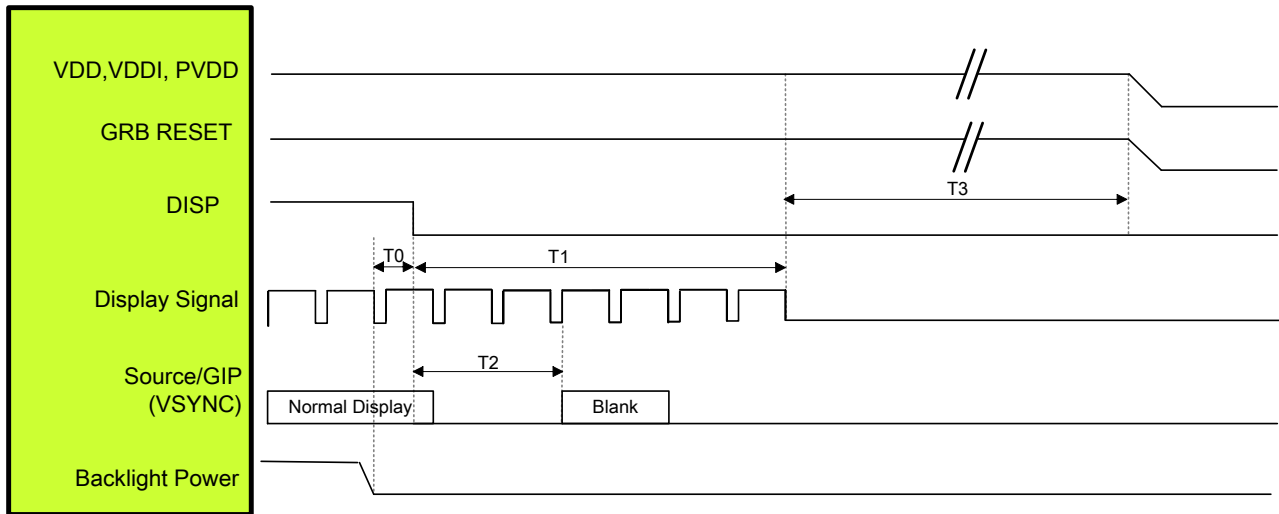

Symbol	Description	Time	Unit
T0	Backlight Power off to DISP="Low"	≥1	ms
T1	DISP="Low" to IC internal voltage discharge complete	≥100	ms
T2	DISP="Low" to Source/GIP scan blank (base on Display Signal Frame Rate 60Hz)	≤50	ms
T3	IC internal voltage discharge is completed to VDD/VDDI/PVDD off	≥0	ms

Note: 1. When DISP pull "H" or "L", IC will execute the internal power on or power off procedures. Please be careful about the timing of DISP and do not interrupt it during power on or power off procedure, otherwise unexpected errors will occur.

2. RGB interface Display signal: DCLK; VSYNC; HSYNC; DE; DR[7:0]; DG[7:0]; DB[7:0].

3. LVDS interface Display signal: DCLK P/N; RX[3:0] P/N.

11.2.2.3 Power Mode with Charge Pump Controller

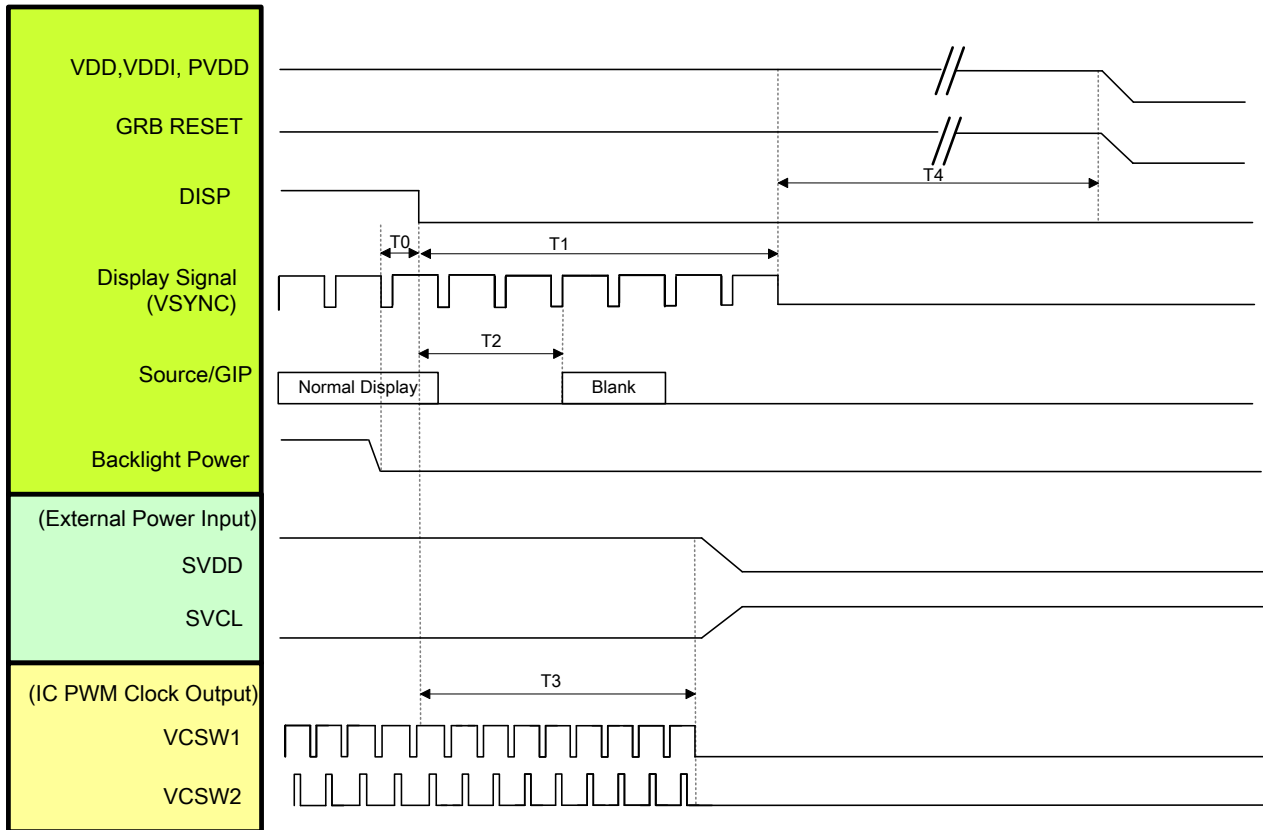

Symbol	Description	Time	Unit
T0	Backlight Power off to DISP="Low"	≥1	ms
T1	DISP="Low" to IC internal voltage discharge complete	≥100	ms
T2	DISP="Low" to Source/GIP scan blank (base on Display Signal Frame Rate 60Hz)	≤50	ms
T3	DISP="Low" to PWM clock stop (base on Display Signal Frame Rate 60Hz)	85	ms
T4	IC internal voltage discharge is completed to VDD/VDDI/PVDD off	≥0	ms

Note: 1. When DISP pull "H" or "L", IC will execute the internal power on or power off procedures .Please be careful about the timing of DISP and do not interrupt it during power on or power off procedure, otherwise unexpected errors will occur.

2. RGB interface Display signal: DCLK; VSYNC; HSYNC; DE; DR[7:0]; DG[7:0]; DB[7:0].

3. LVDS interface Display signal: DCLK P/N; RX[3:0] P/N.

11.2.3 3 Power Mode with External Power Supply

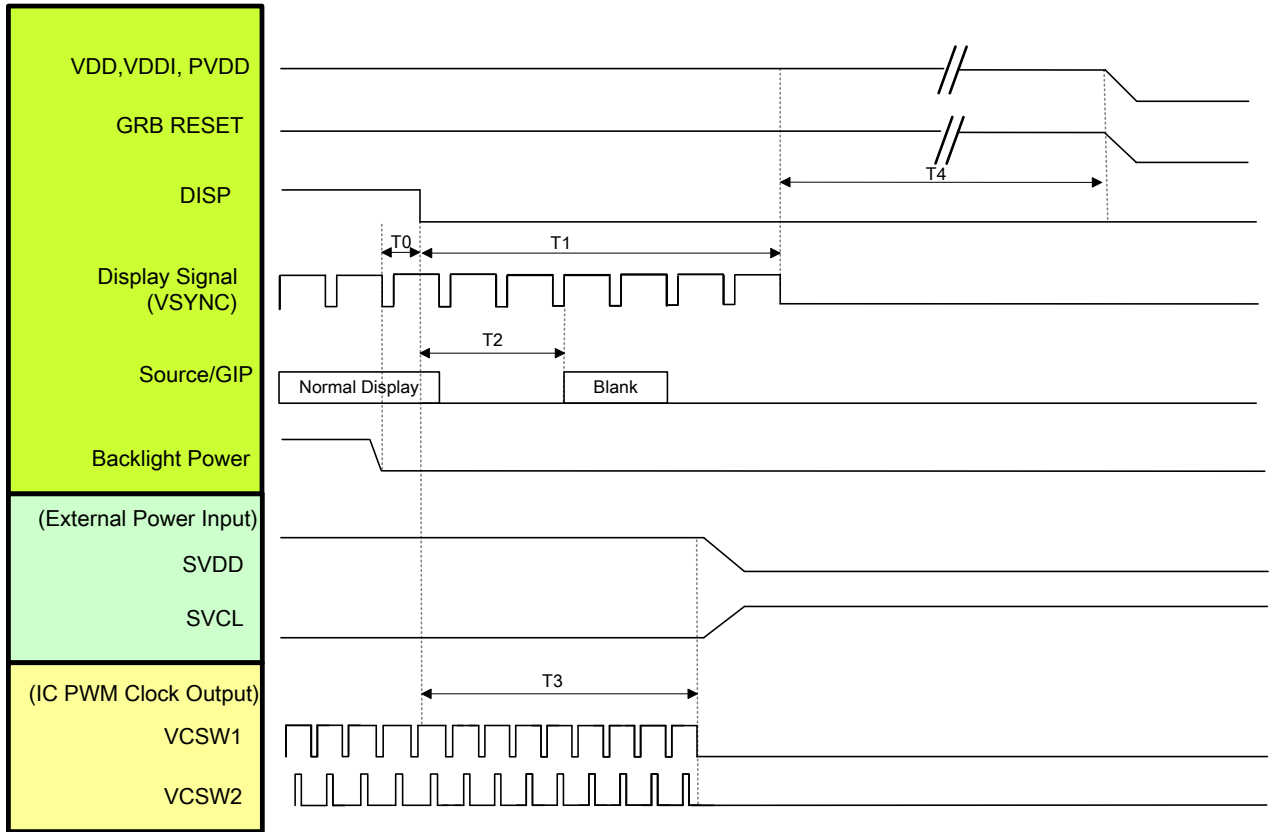

Symbol	Description	Time	Unit
T0	Backlight Power off to DISP="Low"	≥1	ms
T1	DISP="Low" to IC internal voltage discharge complete	100	ms
T2	DISP="Low" to Source/GIP scan blank (base on Display Signal Frame Rate 60Hz)	≤50	ms
T3	DISP="Low" to SVDD /SVCL Power off	85	ms
T4	IC internal voltage discharge is completed to VDD/VDDI/PVDD off	≥0	ms

Note: 1. When DISP pull "H" or "L", IC will execute the internal power on or power off procedures .Please be careful about the timing of

DISP and do not interrupt it during power on or power off procedure, otherwise unexpected errors will occur.

2. RGB interface Display signal: DCLK; VSYNC; HSYNC; DE; DR[7:0]; DG[7:0]; DB[7:0].

3. LVDS interface Display signal: DCLK P/N; RX[3:0] P/N.

12. RECOMMENDED PANEL ROUTING RESISTANCE

The recommended wiring resistance values are given below. The wiring resistance values affect the current capability of the power supply blocks and thus must be designed within the given range.

Pin Number	Pin Name	Unit: ohm
1	VDDI	<1
2	VDD	<1
3	PVDD	<1
4	DGND	<1
5	AGND	<1
6	SGND	<1
7	PGND	<1
8	SVCL	<3
9	SVDD	<3
10	VCOM	<3
11	VGHS	<3
12	VGL	<3
13	GVDD	<50
14	GVCL	<50
15	VGSP	<50
16	VCC	<50
17	RGND	<50
18	AVCL1	<50
19	AVDD1	<50
20	CS	<50
21	SDA	<50
22	SCL	<50
23	DISP	<50
24	GRB	<50
25	DCLKN	<50
26	DCLKP	<50
27	DR[7:0]	<50
28	DG[7:0]	<50
29	DB[7:0]	<50
30	DE	<50
31	VSYNC	<50

Pin Number	Pin Name	Unit: ohm
32	HSYNC	<50
33	AUTODL	<50
34	HDIR	<50
35	VDIR	<50
36	INTF	<50
37	VDPOL_LVDS_SEL	<50
38	HDPOL	<50
39	DCLKPOL	<50
40	VPP	<50
41	BIST_EN	<50
42	LVDS_FMT	<50
43	EXT_S	<50
44	EXT_G	<50
45	VCSW1	<50
46	VCSW2	<50
47	TESTI[14:0]	<50
48	TESTOUT[13:0]	<50
49	DUMMY	<50

13. COLOR FILTER ARRANGEMENT

The IC supports the stripe color filter of dual-gate application. The color filter arrangement on panel is shown below.

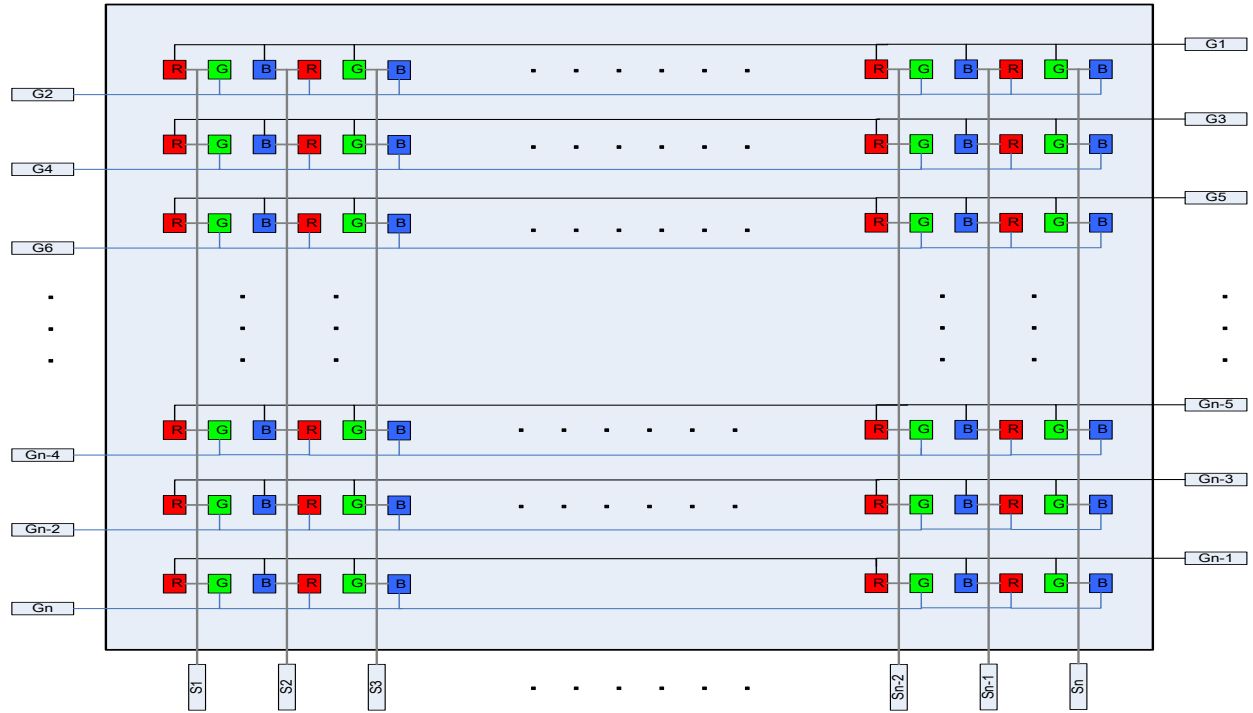

14. REVISION HISTORY

Revision	Description	Date
V1.0	Official Release	2022/09