

## 1. INTRODUCTION

ST7567 is a single-chip dot matrix LCD driver which incorporates LCD controller and common/segment drivers. ST7567 can be connected directly to a microprocessor with 8-bit parallel interface or 4-line serial interface (SPI-4). Display data sent from MPU is stored in the internal Display Data RAM (DDRAM) of 65x132 bits. The display data bits which are stored in DDRAM are directly related to the pixels of LCD panel. ST7567 contains 132 segment-outputs, 64 common-outputs and 1 icon-common-output. With built-in oscillation circuit and low power consumption power circuit, ST7567 generates LCD driving signal without external clock or power, so that it is possible to make a display system with the fewest components and minimal power consumption.

## 2. FEATURES

### Single-chip LCD Controller & Driver

#### On-chip Display Data RAM (DDRAM)

- Capacity: 65x132=8580 bits
- Directly display RAM pattern from DDRAM

#### Selectable Display Duty (by SEL2 & SEL1)

- 1/65 duty : 65 common x 132 segment
- 1/55 duty : 55 common x 132 segment
- 1/49 duty : 49 common x 132 segment
- 1/33 duty : 33 common x 132 segment

#### Microprocessor Interface

- Bidirectional 8-bit parallel interface supports: 8080-series and 6800-series MPU
- Serial interface (SPI-4) is also supported (write only)

#### Abundant Functions

- Display ON/OFF, Normal/Reverse Display Mode, Set Display Start Line, Read IC Status, Set all Display Points ON, Set LCD Bias, Electronic Volume Control, Read-modify-Write, Select Segment Driver Direction,

Power Saving Mode, Select Common Driver Direction, Select Voltage Regulator Resistor Ratio (for V0).

#### External Hardware Reset Pin (RSTB)

#### Built-in Oscillation Circuit

- No external component required

#### Low Power Consumption Analog Circuit

- Voltage Booster (4X, 5X)
- High-accuracy Voltage Regulator for LCD Vop: (Thermal Gradient: -0.05%/°C)
- Voltage Follower for LCD Bias Voltage

#### Wide Operation Voltage Range

- VDD1-VSS1=1.8V~3.3V (Typ.)
- VDD2-VSS2=2.4V~3.3V (Typ.)
- VDD3-VSS3=2.4V~3.3V (Typ.)

#### Temperature Range: -30~85°C

#### Package Type: COG

**ST7567****6800 , 8080 , 4-Line**

Sitronix Technology Corp. reserves the right to change the contents in this document without prior notice.

## 3-1. ST7567 COG OUTLINE

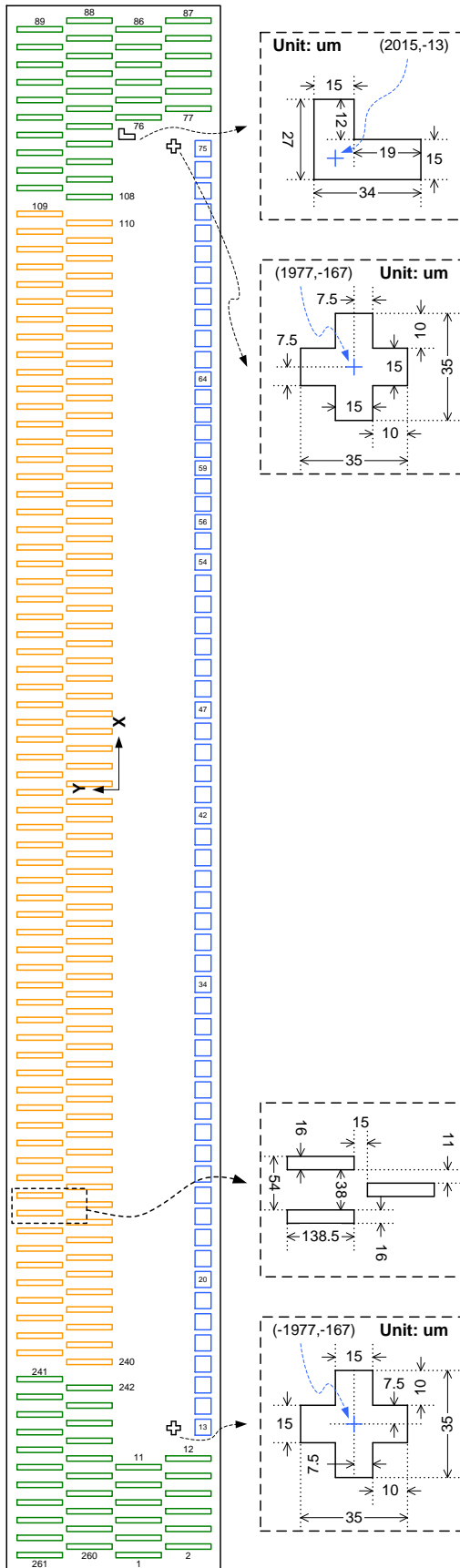

**Chip Size: 4840 X 660**

**Bump Height: 9 (for G4A-1)**

**9 (for G4B-1)**

**Unit: um**

Part Number	Chip Thickness
ST7567-G4	300
Bump Size	
PAD No.	Size
1~12, 76~261	16 X 138.5
13~55, 65~75	50 X 45
56~64	40 x 45
Bump Space (minimum)	
PAD No.	Space
1~12, 76~87, 88~108, 109~240, 241~261	Refer to Fig 1
13~75	15

**\* Refer to section "PAD CENTER COORDINATES" for ITO layout.**

**Fig 1. Chip Outline**

### 3-2. PAD CENTER COORDINATES

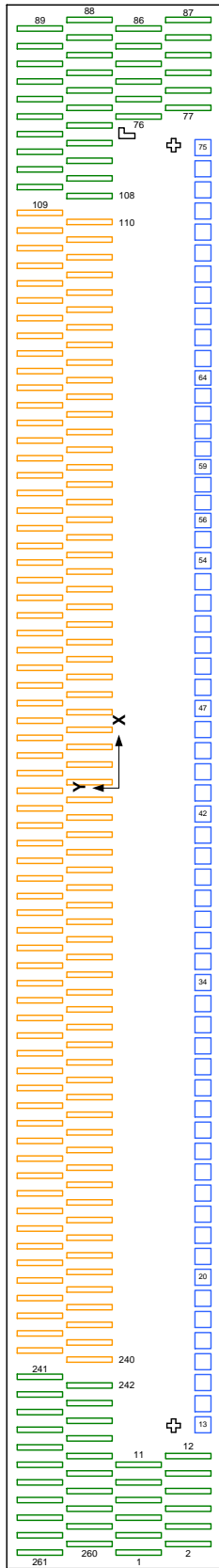

Fig 2. PAD Location

### 65 Duty

PAD NO.	PIN Name	X	Y
1	COM[53]	-2363.00	-74.25
2	COM[54]	-2336.00	-227.75
3	COM[55]	-2309.00	-74.25
4	COM[56]	-2282.00	-227.75
5	COM[57]	-2255.00	-74.25
6	COM[58]	-2228.00	-227.75
7	COM[59]	-2201.00	-74.25
8	COM[60]	-2174.00	-227.75
9	COM[61]	-2147.00	-74.25
10	COM[62]	-2120.00	-227.75
11	COM[63]	-2093.00	-74.25
12	COMS1	-2066.00	-227.75
13	CL	-1970.00	-274.50
14	CSB	-1905.00	-274.50
15	RSTB	-1840.00	-274.50
16	A0	-1775.00	-274.50
17	RWR	-1710.00	-274.50
18	ERD	-1645.00	-274.50
19	VDDH	-1580.00	-274.50
20	D0	-1515.00	-274.50
21	D1	-1450.00	-274.50
22	D2	-1385.00	-274.50
23	D3	-1320.00	-274.50
24	D4	-1255.00	-274.50
25	D5	-1190.00	-274.50
26	D6	-1125.00	-274.50
27	D7	-1060.00	-274.50
28	VDD1	-995.00	-274.50
29	VDD1	-930.00	-274.50
30	VDD2	-865.00	-274.50
31	VDD2	-800.00	-274.50
32	VDD2	-735.00	-274.50
33	VDD3	-670.00	-274.50
34	VSS1	-605.00	-274.50
35	VSS1	-540.00	-274.50
36	VSS3	-475.00	-274.50
37	VSS2	-410.00	-274.50
38	VSS2	-345.00	-274.50
39	VSS2	-280.00	-274.50
40	V0in	-215.00	-274.50

PAD NO.	PIN Name	X	Y
41	V0in	-150.00	-274.50
42	V0s	-85.00	-274.50
43	V0out	-20.00	-274.50
44	V0out	45.00	-274.50
45	XV0out	110.00	-274.50
46	XV0out	175.00	-274.50
47	XV0s	240.00	-274.50
48	XV0in	305.00	-274.50
49	XV0in	370.00	-274.50
50	VMO	435.00	-274.50
51	VMO	500.00	-274.50
52	VGin	565.00	-274.50
53	Vgin	630.00	-274.50
54	VGs	695.00	-274.50
55	Vgout	760.00	-274.50
56	T[6]	820.00	-274.50
57	T[7]	875.00	-274.50
58	T[8]	930.00	-274.50
59	TFCOM	985.00	-274.50
60	T[1]	1040.00	-274.50
61	T[2]	1095.00	-274.50
62	T[3]	1150.00	-274.50
63	T[4]	1205.00	-274.50
64	T[5]	1260.00	-274.50
65	Vref	1320.00	-274.50
66	VSSL	1385.00	-274.50
67	VDDH	1450.00	-274.50
68	C86	1515.00	-274.50
69	PSB	1580.00	-274.50
70	SEL1	1645.00	-274.50
71	VSSL	1710.00	-274.50
72	SEL2	1775.00	-274.50
73	VDD1	1840.00	-274.50
74	VDD2	1905.00	-274.50
75	VDD3	1970.00	-274.50
76	COM[31]	2066.00	-74.25
77	COM[30]	2093.00	-227.75
78	COM[29]	2120.00	-74.25
79	COM[28]	2147.00	-227.75
80	COM[27]	2174.00	-74.25

PAD NO.	PIN Name	X	Y
81	COM[26]	2201.00	-227.75
82	COM[25]	2228.00	-74.25
83	COM[24]	2255.00	-227.75
84	COM[23]	2282.00	-74.25
85	COM[22]	2309.00	-227.75
86	COM[21]	2336.00	-74.25
87	COM[20]	2363.00	-227.75
88	COM[19]	2363.00	74.25
89	COM[18]	2336.00	227.75
90	COM[17]	2309.00	74.25
91	COM[16]	2282.00	227.75
92	COM[15]	2255.00	74.25
93	COM[14]	2228.00	227.75
94	COM[13]	2201.00	74.25
95	COM[12]	2174.00	227.75
96	COM[11]	2147.00	74.25
97	COM[10]	2120.00	227.75
98	COM[9]	2093.00	74.25
99	COM[8]	2066.00	227.75
100	COM[7]	2039.00	74.25
101	COM[6]	2012.00	227.75
102	COM[5]	1985.00	74.25
103	COM[4]	1958.00	227.75
104	COM[3]	1931.00	74.25
105	COM[2]	1904.00	227.75
106	COM[1]	1877.00	74.25
107	COM[0]	1850.00	227.75
108	COMS2	1823.00	74.25
109	SEG[0]	1768.50	227.75
110	SEG[1]	1741.50	74.25
111	SEG[2]	1714.50	227.75
112	SEG[3]	1687.50	74.25
113	SEG[4]	1660.50	227.75
114	SEG[5]	1633.50	74.25
115	SEG[6]	1606.50	227.75
116	SEG[7]	1579.50	74.25
117	SEG[8]	1552.50	227.75
118	SEG[9]	1525.50	74.25
119	SEG[10]	1498.50	227.75
120	SEG[11]	1471.50	74.25

PAD NO.	PIN Name	X	Y
121	SEG[12]	1444.50	227.75
122	SEG[13]	1417.50	74.25
123	SEG[14]	1390.50	227.75
124	SEG[15]	1363.50	74.25
125	SEG[16]	1336.50	227.75
126	SEG[17]	1309.50	74.25
127	SEG[18]	1282.50	227.75
128	SEG[19]	1255.50	74.25
129	SEG[20]	1228.50	227.75
130	SEG[21]	1201.50	74.25
131	SEG[22]	1174.50	227.75
132	SEG[23]	1147.50	74.25
133	SEG[24]	1120.50	227.75
134	SEG[25]	1093.50	74.25
135	SEG[26]	1066.50	227.75
136	SEG[27]	1039.50	74.25
137	SEG[28]	1012.50	227.75
138	SEG[29]	985.50	74.25
139	SEG[30]	958.50	227.75
140	SEG[31]	931.50	74.25
141	SEG[32]	904.50	227.75
142	SEG[33]	877.50	74.25
143	SEG[34]	850.50	227.75
144	SEG[35]	823.50	74.25
145	SEG[36]	796.50	227.75
146	SEG[37]	769.50	74.25
147	SEG[38]	742.50	227.75
148	SEG[39]	715.50	74.25
149	SEG[40]	688.50	227.75
150	SEG[41]	661.50	74.25
151	SEG[42]	634.50	227.75
152	SEG[43]	607.50	74.25
153	SEG[44]	580.50	227.75
154	SEG[45]	553.50	74.25
155	SEG[46]	526.50	227.75
156	SEG[47]	499.50	74.25
157	SEG[48]	472.50	227.75
158	SEG[49]	445.50	74.25
159	SEG[50]	418.50	227.75
160	SEG[51]	391.50	74.25

PAD NO.	PIN Name	X	Y
161	SEG[52]	364.50	227.75
162	SEG[53]	337.50	74.25
163	SEG[54]	310.50	227.75
164	SEG[55]	283.50	74.25
165	SEG[56]	256.50	227.75
166	SEG[57]	229.50	74.25
167	SEG[58]	202.50	227.75
168	SEG[59]	175.50	74.25
169	SEG[60]	148.50	227.75
170	SEG[61]	121.50	74.25
171	SEG[62]	94.50	227.75
172	SEG[63]	67.50	74.25
173	SEG[64]	40.50	227.75
174	SEG[65]	13.50	74.25
175	SEG[66]	-13.50	227.75
176	SEG[67]	-40.50	74.25
177	SEG[68]	-67.50	227.75
178	SEG[69]	-94.50	74.25
179	SEG[70]	-121.50	227.75
180	SEG[71]	-148.50	74.25
181	SEG[72]	-175.50	227.75
182	SEG[73]	-202.50	74.25
183	SEG[74]	-229.50	227.75
184	SEG[75]	-256.50	74.25
185	SEG[76]	-283.50	227.75
186	SEG[77]	-310.50	74.25
187	SEG[78]	-337.50	227.75
188	SEG[79]	-364.50	74.25
189	SEG[80]	-391.50	227.75
190	SEG[81]	-418.50	74.25
191	SEG[82]	-445.50	227.75
192	SEG[83]	-472.50	74.25
193	SEG[84]	-499.50	227.75
194	SEG[85]	-526.50	74.25
195	SEG[86]	-553.50	227.75
196	SEG[87]	-580.50	74.25
197	SEG[88]	-607.50	227.75
198	SEG[89]	-634.50	74.25
199	SEG[90]	-661.50	227.75
200	SEG[91]	-688.50	74.25

PAD NO.	PIN Name	X	Y
201	SEG[92]	-715.50	227.75
202	SEG[93]	-742.50	74.25
203	SEG[94]	-769.50	227.75
204	SEG[95]	-796.50	74.25
205	SEG[96]	-823.50	227.75
206	SEG[97]	-850.50	74.25
207	SEG[98]	-877.50	227.75
208	SEG[99]	-904.50	74.25
209	SEG[100]	-931.50	227.75
210	SEG[101]	-958.50	74.25
211	SEG[102]	-985.50	227.75
212	SEG[103]	-1012.50	74.25
213	SEG[104]	-1039.50	227.75
214	SEG[105]	-1066.50	74.25
215	SEG[106]	-1093.50	227.75
216	SEG[107]	-1120.50	74.25
217	SEG[108]	-1147.50	227.75
218	SEG[109]	-1174.50	74.25
219	SEG[110]	-1201.50	227.75
220	SEG[111]	-1228.50	74.25
221	SEG[112]	-1255.50	227.75
222	SEG[113]	-1282.50	74.25
223	SEG[114]	-1309.50	227.75
224	SEG[115]	-1336.50	74.25
225	SEG[116]	-1363.50	227.75
226	SEG[117]	-1390.50	74.25
227	SEG[118]	-1417.50	227.75
228	SEG[119]	-1444.50	74.25
229	SEG[120]	-1471.50	227.75
230	SEG[121]	-1498.50	74.25
231	SEG[122]	-1525.50	227.75
232	SEG[123]	-1552.50	74.25
233	SEG[124]	-1579.50	227.75
234	SEG[125]	-1606.50	74.25
235	SEG[126]	-1633.50	227.75
236	SEG[127]	-1660.50	74.25
237	SEG[128]	-1687.50	227.75
238	SEG[129]	-1714.50	74.25
239	SEG[130]	-1741.50	227.75
240	SEG[131]	-1768.50	74.25

PAD NO.	PIN Name	X	Y
241	COM[32]	-1823.00	227.75
242	COM[33]	-1850.00	74.25
243	COM[34]	-1877.00	227.75
244	COM[35]	-1904.00	74.25
245	COM[36]	-1931.00	227.75
246	COM[37]	-1958.00	74.25
247	COM[38]	-1985.00	227.75
248	COM[39]	-2012.00	74.25
249	COM[40]	-2039.00	227.75
250	COM[41]	-2066.00	74.25
251	COM[42]	-2093.00	227.75
252	COM[43]	-2120.00	74.25
253	COM[44]	-2147.00	227.75
254	COM[45]	-2174.00	74.25
255	COM[46]	-2201.00	227.75
256	COM[47]	-2228.00	74.25
257	COM[48]	-2255.00	227.75
258	COM[49]	-2282.00	74.25
259	COM[50]	-2309.00	227.75
260	COM[51]	-2336.00	74.25
261	COM[52]	-2363.00	227.75

Note:

1. Unit: um
2. This is the default PAD Center Coordinate Table with 1/65 Duty. Other duty output mapping can be found in Section FUNCTION DESCRIPTION and Fig 9.
3. Tolerance: +/- 0.05 um.
4. **The definition of pin name is in full duty (65 duty).**
5. **The definition of output pin name in different duty (55 Duty, 49 Duty and 33 Duty) please refers Fig 9.**

4. BLOCK DIAGRAM

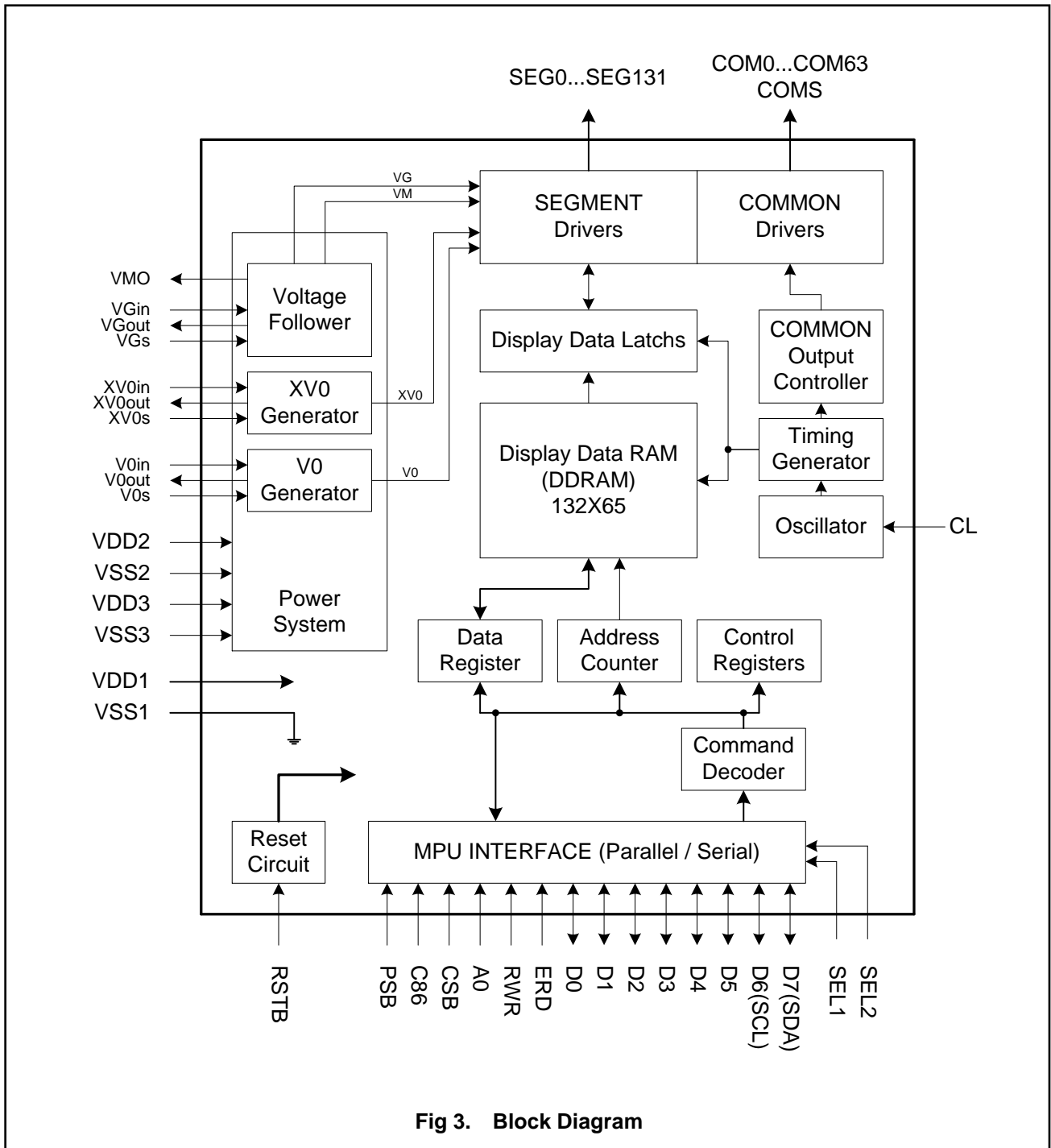

Fig 3. Block Diagram

## ⇒ PIN DESCRIPTION

### LCD Driver Output Pins

Pin Name	Type	Description	No. of Pins																										
SEG0 to SEG131	O	LCD segment driver outputs. The display data and the frame control the output voltage.	132																										
		<table border="1"> <thead> <tr> <th rowspan="2">Display data</th> <th rowspan="2">Frame</th> <th colspan="2">Segment Driver Output Voltage</th> </tr> <tr> <th>Normal Display</th> <th>Inverse Display</th> </tr> </thead> <tbody> <tr> <td>H</td> <td>+</td> <td>VG</td> <td>VSS</td> </tr> <tr> <td>H</td> <td>-</td> <td>VSS</td> <td>VG</td> </tr> <tr> <td>L</td> <td>+</td> <td>VSS</td> <td>VG</td> </tr> <tr> <td>L</td> <td>-</td> <td>VG</td> <td>VSS</td> </tr> <tr> <td colspan="2">Display OFF, Power Save</td> <td>VSS</td> <td>VSS</td> </tr> </tbody> </table>		Display data	Frame	Segment Driver Output Voltage		Normal Display	Inverse Display	H	+	VG	VSS	H	-	VSS	VG	L	+	VSS	VG	L	-	VG	VSS	Display OFF, Power Save		VSS	VSS
		Display data				Frame	Segment Driver Output Voltage																						
				Normal Display	Inverse Display																								
		H		+	VG	VSS																							
		H		-	VSS	VG																							
L	+	VSS	VG																										
L	-	VG	VSS																										
Display OFF, Power Save		VSS	VSS																										
COM0 to COM63	O	LCD common driver outputs. The internal scanning signal and the frame control the output voltage.	64																										
		<table border="1"> <thead> <tr> <th rowspan="2">Scan signal</th> <th rowspan="2">Frame</th> <th colspan="2">Common Driver Output Voltage</th> </tr> <tr> <th>Normal Display</th> <th>Inverse Display</th> </tr> </thead> <tbody> <tr> <td>H</td> <td>+</td> <td colspan="2">XV0</td> </tr> <tr> <td>H</td> <td>-</td> <td colspan="2">V0</td> </tr> <tr> <td>L</td> <td>+</td> <td colspan="2">VM</td> </tr> <tr> <td>L</td> <td>-</td> <td colspan="2">VM</td> </tr> <tr> <td colspan="2">Display OFF, Power Save</td> <td colspan="2">VSS</td> </tr> </tbody> </table>		Scan signal	Frame	Common Driver Output Voltage		Normal Display	Inverse Display	H	+	XV0		H	-	V0		L	+	VM		L	-	VM		Display OFF, Power Save		VSS	
		Scan signal				Frame	Common Driver Output Voltage																						
				Normal Display	Inverse Display																								
		H		+	XV0																								
		H		-	V0																								
L	+	VM																											
L	-	VM																											
Display OFF, Power Save		VSS																											
COMS1, COMS2 (COMS)	O	LCD common driver outputs for icons. The output signals of these two pins are the same. When icon feature is not used, these pins should be left open.	2																										

### Microprocessor Interface Pins

Pin Name	Type	Description	No. of Pins												
RSTB	I	Hardware reset input pin. When RSTB is "L", internal initialization is executed and the internal registers will be initialized.	1												
CSB	I	Chip select input pin. Interface access is enabled when CSB is "L". When CSB is non-active (CSB="H"), D[7:0] pins are high impedance.	1												
A0	I	It determines whether the access is related to data or command. A0="H" : Indicates that signals on D[7:0] are display data. A0="L" : Indicates that signals on D[7:0] are command.	1												
RWR	I	Read/Write execution control pin. When PSB is "H",	1												
		<table border="1"> <thead> <tr> <th>C86</th> <th>MPU Type</th> <th>RWR</th> <th>Description</th> </tr> </thead> <tbody> <tr> <td>H</td> <td>6800 series</td> <td>R/W</td> <td>Read/Write control input pin. R/W="H": read. R/W="L": write.</td> </tr> <tr> <td>L</td> <td>8080 series</td> <td>/WR</td> <td>Write enable input pin. Signals on D[7:0] will be latched at the rising edge of /WR signal.</td> </tr> </tbody> </table>		C86	MPU Type	RWR	Description	H	6800 series	R/W	Read/Write control input pin. R/W="H": read. R/W="L": write.	L	8080 series	/WR	Write enable input pin. Signals on D[7:0] will be latched at the rising edge of /WR signal.
		C86		MPU Type	RWR	Description									
H	6800 series	R/W	Read/Write control input pin. R/W="H": read. R/W="L": write.												
L	8080 series	/WR	Write enable input pin. Signals on D[7:0] will be latched at the rising edge of /WR signal.												
RWR is not used in serial interface and should fix to "H" by VDD1 or VDDH.															



Pin Name	Type	Description	No. of Pins												
ERD	I	Read/Write execution control pin. When PSB is "H",	1												
		<table border="1"> <thead> <tr> <th>C86</th> <th>MPU Type</th> <th>ERD</th> <th>Description</th> </tr> </thead> <tbody> <tr> <td>H</td> <td>6800 series</td> <td>E</td> <td>Read/Write control input pin. R/W="H": When E is "H", D[7:0] are in output mode. R/W="L": Signals on D[7:0] are latched at the falling edge of E signal.</td> </tr> <tr> <td>L</td> <td>8080 series</td> <td>/RD</td> <td>Read enable input pin. When /RD is "L", D[7:0] are in output mode.</td> </tr> </tbody> </table>		C86	MPU Type	ERD	Description	H	6800 series	E	Read/Write control input pin. R/W="H": When E is "H", D[7:0] are in output mode. R/W="L": Signals on D[7:0] are latched at the falling edge of E signal.	L	8080 series	/RD	Read enable input pin. When /RD is "L", D[7:0] are in output mode.
		C86		MPU Type	ERD	Description									
H	6800 series	E	Read/Write control input pin. R/W="H": When E is "H", D[7:0] are in output mode. R/W="L": Signals on D[7:0] are latched at the falling edge of E signal.												
L	8080 series	/RD	Read enable input pin. When /RD is "L", D[7:0] are in output mode.												
ERD is not used in serial interface and should fix to "H" by VDD1 or VDDH.															
D[7:0]	I/O	<b>When using 8-bit parallel interface: (6800 or 8080 mode)</b> 8-bit bi-directional data bus. Connect to the data bus of 8-bit microprocessor. When CSB is non-active (CSB="H"), D[7:0] pins are high impedance.	8												
	I	<b>When using serial interface: 4-LINE</b> D7=SDA : Serial data input. D6=SCL : Serial clock input. D[5:0] are not used and should connect to "H" by VDD1 or VDDH. When CSB is non-active (CSB="H"), D[7:0] pins are high impedance.													

**Note:**

1. After VDD1 is turned ON, any MPU interface pins cannot be left floating.

## Configuration Pins

Pin Name	Type	Description	No. of Pins																				
VDDH	O	Logic "1" level for option pins which should connected to "H".	2																				
VSSL	O	Logic "0" level for option pins which should connected to "L".	2																				
PSB	I	PSB selects the interface type: Serial or Parallel.	1																				
C86	I	C86 selects the microprocessor type in parallel interface mode.	1																				
		<table border="1"> <thead> <tr> <th>PSB</th> <th>C86</th> <th>Selected Interface</th> </tr> </thead> <tbody> <tr> <td>"H"</td> <td>"H"</td> <td>Parallel 6800 Series MPU Interface</td> </tr> <tr> <td>"H"</td> <td>"L"</td> <td>Parallel 8080 Series MPU Interface</td> </tr> <tr> <td>"L"</td> <td>"X"</td> <td>Serial 4-Line SPI Interface</td> </tr> </tbody> </table>		PSB	C86	Selected Interface	"H"	"H"	Parallel 6800 Series MPU Interface	"H"	"L"	Parallel 8080 Series MPU Interface	"L"	"X"	Serial 4-Line SPI Interface								
		PSB		C86	Selected Interface																		
"H"	"H"	Parallel 6800 Series MPU Interface																					
"H"	"L"	Parallel 8080 Series MPU Interface																					
"L"	"X"	Serial 4-Line SPI Interface																					
Please refer to "APPLICATION NOTES" and "Microprocessor Interface" (Section 6) for detailed connection of the selected interface.																							
SEL[2:1]	I	These pins select the display duty and bias of ST7567.	2																				
		<table border="1"> <thead> <tr> <th>SEL2</th> <th>SEL1</th> <th>Duty</th> <th>Bias</th> </tr> </thead> <tbody> <tr> <td>"L"</td> <td>"L"</td> <td>1/65</td> <td>1/9 or 1/7</td> </tr> <tr> <td>"L"</td> <td>"H"</td> <td>1/49</td> <td>1/8 or 1/6</td> </tr> <tr> <td>"H"</td> <td>"L"</td> <td>1/33</td> <td>1/6 or 1/5</td> </tr> <tr> <td>"H"</td> <td>"H"</td> <td>1/55</td> <td>1/8 or 1/6</td> </tr> </tbody> </table>		SEL2	SEL1	Duty	Bias	"L"	"L"	1/65	1/9 or 1/7	"L"	"H"	1/49	1/8 or 1/6	"H"	"L"	1/33	1/6 or 1/5	"H"	"H"	1/55	1/8 or 1/6
		SEL2		SEL1	Duty	Bias																	
		"L"		"L"	1/65	1/9 or 1/7																	
		"L"		"H"	1/49	1/8 or 1/6																	
"H"	"L"	1/33	1/6 or 1/5																				
"H"	"H"	1/55	1/8 or 1/6																				
<b>Note:</b>																							
1. The detailed definition of output pin name can be found in Fig 9.																							

## Power System Pins

Pin Name	Type	Description	No. of Pins
VDD1	Power	Digital power. If VDD1=VDD2, connect to VDD2 externally.	3
VDD2	Power	Analog power. If VDD1=VDD2, connect to VDD1 externally.	4
VDD3	Power	Power for reference voltage circuit.	2
VSS1	Power	Digital ground. Connect to VSS2 externally.	2
VSS2	Power	Analog ground. Connect to VSS1 externally.	3
VSS3	Power	Ground for reference voltage circuit.	1
V0out V0in V0s	Power	V0 is the LCD driving voltage for common circuits at negative frame. V0out is the output of V0 regulator. V0s is the feedback of V0 regulator. V0in is the V0 input of common circuits. Be sure that: $V0 \geq VG > VM > VSS \geq XV0$ (under operation). V0out, V0in & V0s should be connected together in ITO layout.	2 2 1
XV0out XV0in XV0s	Power	XV0 is the LCD driving voltage for common circuits at positive frame. XV0out is the output of XV0 regulator. XV0s is the feedback of XV0 regulator. XV0in is the V0 input of common circuits. XV0out, XV0in & XV0s should be connected together in ITO layout.	2 2 1
Vgout Vgin VGs	Power	VG is the LCD driving voltage for segment circuits. Vgout is the output of VG regulator. VGs is the feedback of VG regulator. Vgin is the VG input of segment circuits. Vgout, Vgin & VGs should be connected together in ITO layout. $1.6 \leq VG < VDD2$ .	1 2 1
VMO	Power	VM is the LCD driving voltage for common circuits. $0.8V \leq VM < VDD2$ .	2

## Test Pins

Pin Name	Type	Description	No. of Pins
Vref	T	Test pin for power system. This pin must be left open (without any kinds of connection).	1
T1~T8	T	Do NOT use. Reserved for testing. Must be floating.	8
TFCOM	T	Do NOT use. Reserved for testing. Must be floating.	1
CL	T	Do NOT use. Reserved for testing. Must be floating.	1

## Recommend ITO Resistance

Pin Name	ITO Resistance
VMO, Vref, T[1:8], TFCOM, CL	Floating
VDD1, VDD2, VDD3, VSS1, VSS2, VSS3	< 100Ω
V0(V0in, V0out, V0s), VG(Vgin, Vgout, VGs), XV0(XV0in, XV0out, XV0s)	< 300Ω
A0, RWR, ERD, CSB, D[7:0]	< 1KΩ
PSB, C86, SEL[2:1]	< 5KΩ
RSTB *1	< 10KΩ

Note:

1. To prevent the ESD pulse resetting the internal register, applications should increase the resistance of RSTB signal (add a series resistor or increase ITO resistance). The value is different from modules.
2. The option setting to be "H" should connect to VDD1 or VDDH.
3. The option setting to be "L" should connect to VSS1 or VSSL.

## FUNCTION DESCRIPTION

### Microprocessor Interface

#### Chip Select Input

CSB pin is used for chip selection. When CSB is “L”, the microprocessor interface is enabled and ST7567 can interface with an MPU. When CSB is “H”, the inputs of A0, ERD and RWR with any combination will be ignored and D[7:0] are high impedance. In 4-Line serial interface, the internal shift register and serial counter are reset when CSB is “H”.

#### Interface Selection

The interface selection is controlled by C86 and PSB pins. The selection for parallel or serial interface is shown in Table 1.

**Table 1. Parallel/Serial Interface Mode**

PSB	C86	CSB	A0	ERD	RWR	D[7:0]	MPU Interface
“H”	“H”	CSB	A0	E	R/W	D[7:0]	6800-series parallel interface
“H”	“L”			/RD	/WR		8080-series parallel interface
“L”	“X”			---	---	Refer to serial interface.	4-Line SPI interface

⇒ The un-used pins are marked as “---” and should be fixed to “H” by VDD1 or VDDH.

#### Parallel Interface

When PSB= “H”, the 8-bit bi-directional parallel interface is enabled and the type of MPU is selected by “C86” pin as shown in Table 2. The data transfer type is determined by signals on A0, ERD and RWR as shown in Table 3.

**Table 2. Microprocessor Selection for Parallel Interface**

PSB	C86	CSB	A0	ERD	RWR	D[7:0]	MPU Interface
“H”	“H”	CSB	A0	E	R/W	D[7:0]	6800-series parallel interface
“H”	“L”			/RD	/WR		8080-series parallel interface

**Table 3. Parallel Data Transfer Type**

Common Pins		6800-Series		8080-Series		Description
CSB	A0	E (ERD)	R/W (RWR)	/RD (ERD)	/WR (RWR)	
“L”	“H”	“H”	“H”	“L”	“H”	Display data read out
	“H”	“H”	“L”	“H”	“L”	Display data write
	“L”	“H”	“H”	“L”	“H”	Internal status read
	“L”	“H”	“L”	“H”	“L”	Writes to internal register (instruction)

#### Setting Serial Interface

Serial Mode	PSB	C86	CSB	A0	ERD	RWR	D[7:0]
4-Line SPI interface	“L”	X	CSB	A0	---	---	SDA, SCLK, ---, ---, ---, ---, ---, ---

\* The un-used pins are marked as “---” and should be fixed to “H” by VDD1 or VDDH.

\* C86 is marked as “X” and can be fixed to “H” or “L”.

Note:

1. The option setting to be “H” should connect to VDD1 or VDDH.
2. The option setting to be “L” should connect to VSS1 or VSSL.

## 4-line SPI interface (PSB="L", C86="H" or "L")

When ST7567 is active (CSB="L"), serial data (SDA) and serial clock (SCLK) inputs are enabled. When ST7567 is not active (CSB="H"), the internal 8-bit shift register and 3-bit counter are reset. Serial data on SDA is latched at the rising edge of serial clock on SCLK. After the 8<sup>th</sup> serial clock, the serial data will be processed to be 8-bit parallel data. The address selection pin (A0), which is latched at the 8<sup>th</sup> clock, indicates the 8-bit parallel data is display data or instruction. The 8-bit parallel data will be display data when A0 is "H" and will be instruction when A0 is "L". The read feature is not available in this mode. The DDRAM column address pointer will be increased by one automatically after each byte of DDRAM access. Please note that the SCLK signal quality is very important and external noise may cause unexpected data/instruction latch.

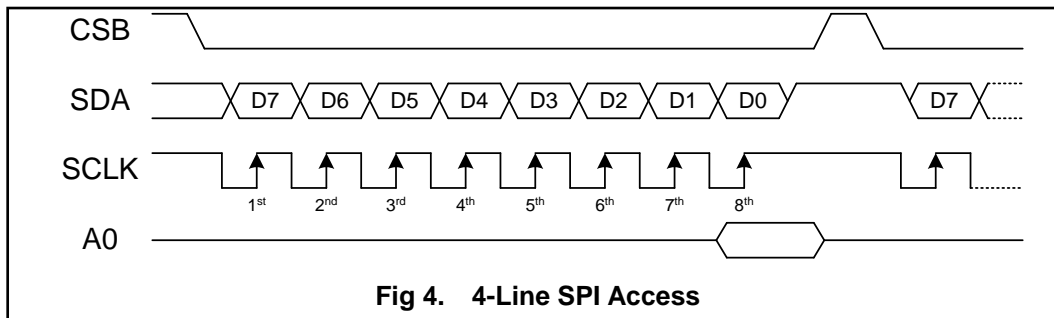

### Note:

- Some MPU will set the interface to be Hi-Z (high impedance) mode when power saving mode or after hardware reset. This is not allowed when the VDD1 of ST7567 is turned ON. Because the floating input (especially for those control pins such as CSB, RSTB, RWR or ERD...) may cause abnormal latch and cause abnormal display.

## Data Transfer

ST7567 uses bus latch and internal data bus for interface data transfer. When writing data from MPU to the DDRAM, data is automatically transferred from the bus latch to the DDRAM as shown in Fig 5. When reading data from the on-chip DDRAM to MPU, the first read cycle reads the content in bus latch (dummy read) and the data that MPU should read will be output at the next read cycle as shown in Fig 6. That means: after setting the target address, a dummy read cycle is required before the following read-operation. Therefore, the data of the specified address cannot be read at the first read of display data right after setting the address, but can be read at the second read of display data.

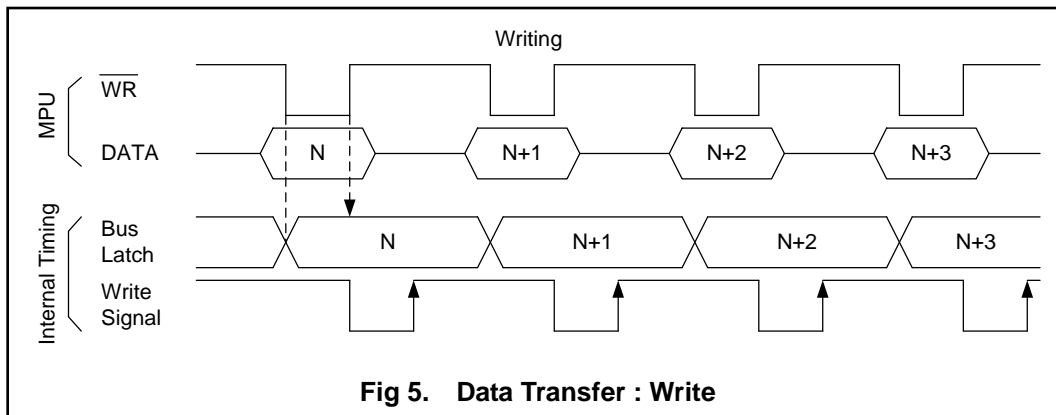

**Fig 5. Data Transfer : Write**

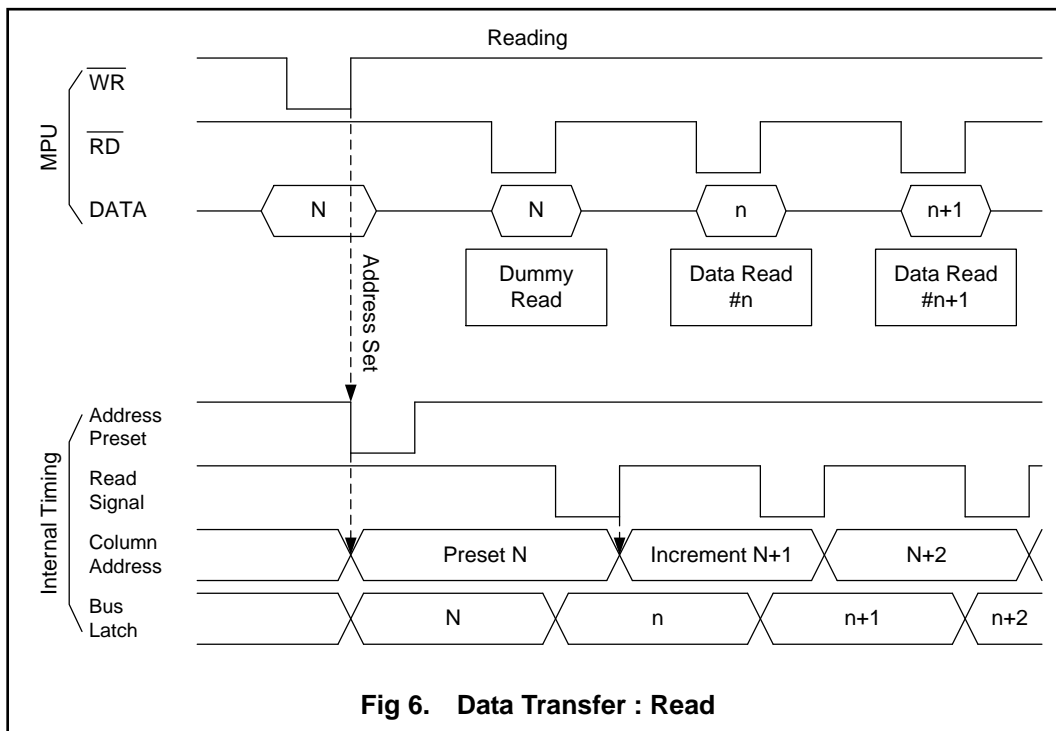

**Fig 6. Data Transfer : Read**

## Display Data RAM (DDRAM)

ST7567 is built-in a RAM with 65X132 bit capacity which stores the display data. The display data RAM (DDRAM) store the dot data of the LCD. It is an addressable array with 132 columns by 65 rows (8-page with 8-bit and 1-page with 1-bit). The X-address is directly related to the column output number. Each pixel can be selected when the page and column addresses are specified (please refer to Fig 7 for detailed illustration). The rows are divided into: 8 pages (Page-0 ~ Page-7) each with 8 lines (for COM0~63) and Page-8 with only 1 line (COMS, for icon). The display data (D7~D0) corresponds to the LCD common-line direction and D0 is on top. All pages can be accessed through D[7:0] directly except icon page. Icon RAM uses only 1-bit of data bus (D0). Refer to Fig 8 for detailed illustration. The microprocessor can write to and read from (only Parallel interfaces) DDRAM by the I/O buffer. Since the LCD controller operates independently, data can be written into DDRAM at the same time as data is being displayed without causing the LCD flicker or data-conflict.

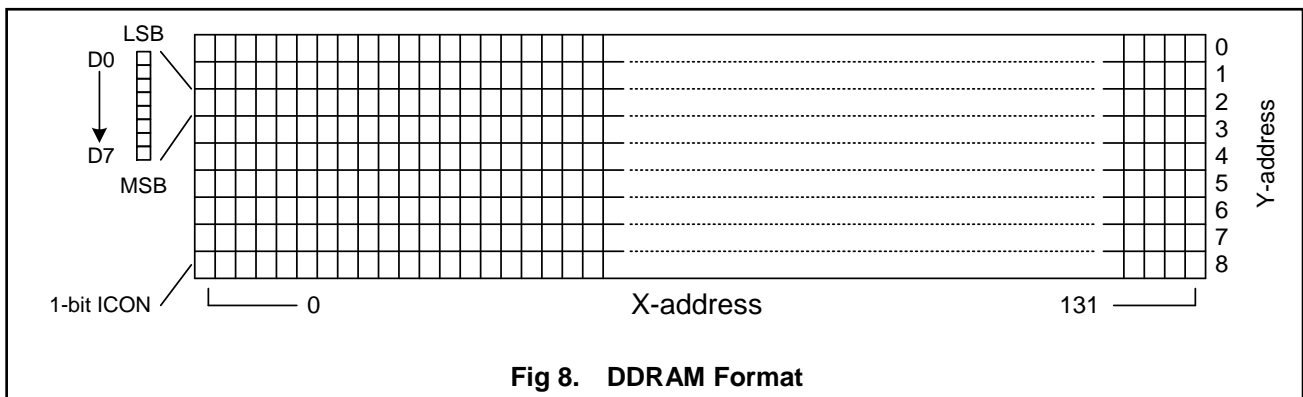
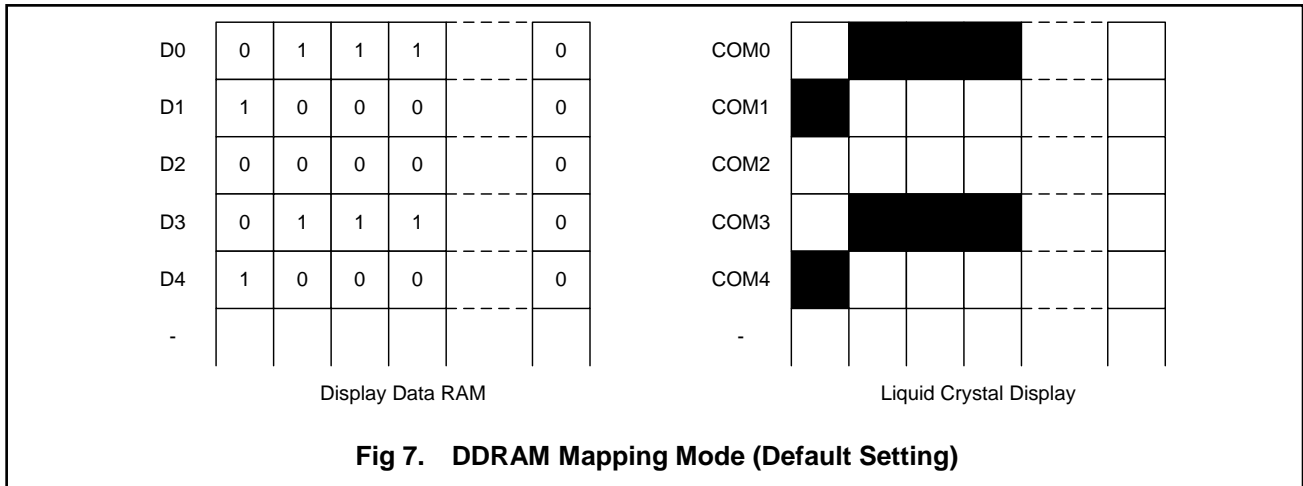

## Addressing

Data is downloaded into the Display Data RAM matrix in ST7567 as byte-format. The Display Data RAM has a matrix of 65 by 132 bits. The address ranges are: X=0~131 (column address), Y=0~8 (page address). Addresses outside these ranges are not allowed.

## Page Address Circuit

This circuit provides the page address of DDRAM. It incorporates 4-bit Page Address Register which can be modified by the "Page Address Set" instruction only. The Page Address must be set before accessing DDRAM content. Page Address "8" is a special RAM area for the icons with only one valid bit: D0.

## Column Address Circuit

The column address of DDRAM is specified by the Column Address Set command. Column Address Circuit has 8-bit preset counter that provides Column Address to the Display Data RAM (DDRAM). This allows MPU accessing DDRAM content continuously. The column address is automatically incremented from the start up to the end column. During auto-increment, the column address returns to the start address as the end column (counter value) is reached.

Furthermore, Register MX and MY makes it possible to invert the relationship between the DDRAM and the outputs (COM/SEG). It is necessary to rewrite the display data into DDRAM after changing MX setting.



The relation between DDRAM and outputs with different MX or MY setting is shown below.

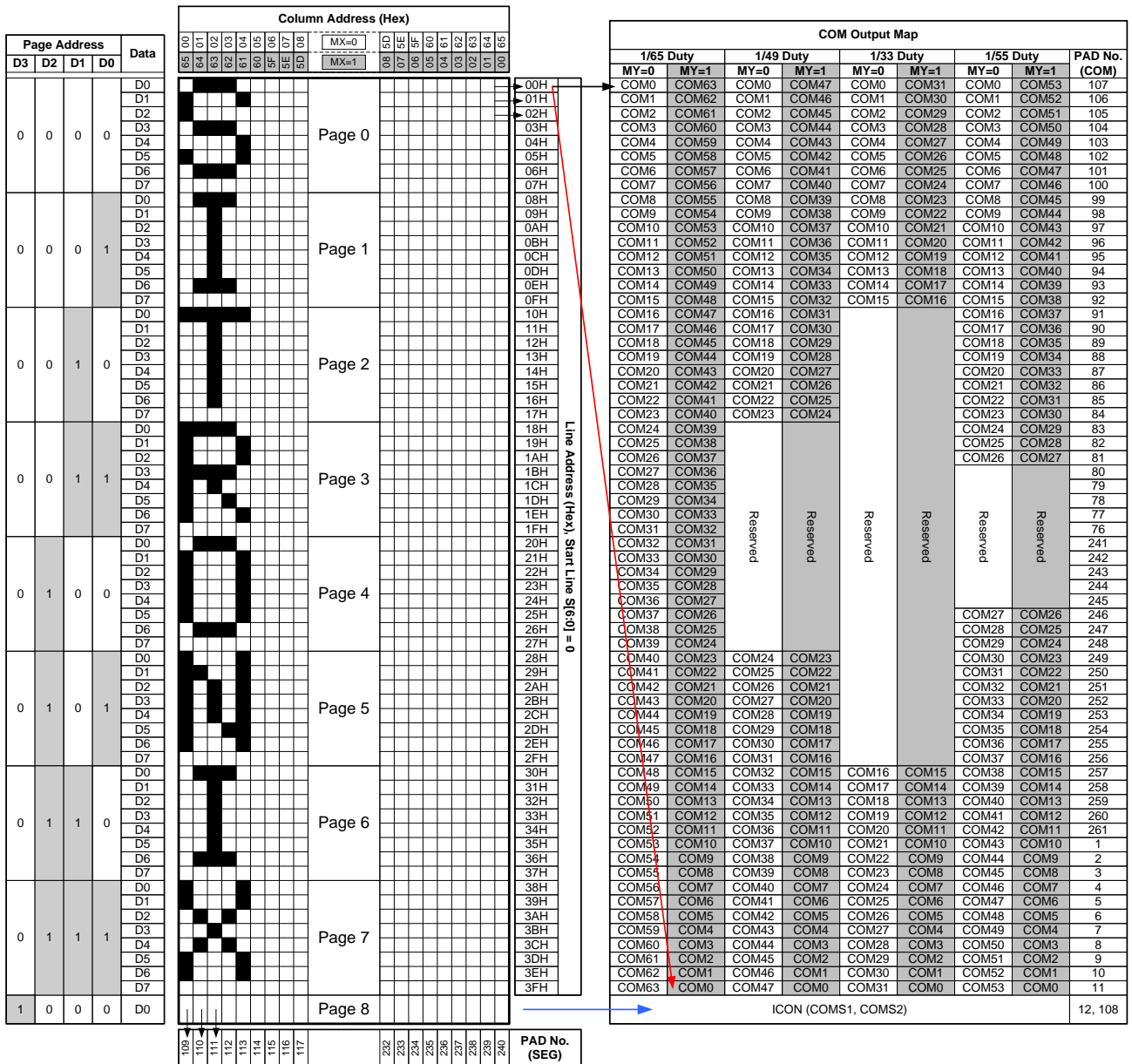

Fig 9. DDRAM and Output Map (COM/SEG)

## Line Address Circuit

The Line Address Circuit incorporates a counter and a Line Address register which is changed only by the “Display Start Line Set” instruction. This circuit assigns DDRAM a Line Address corresponding to the first display line (COM0). Therefore, by setting Line Address repeatedly, ST7567 can realize the screen scrolling without changing the contents of DDRAM as shown in Fig 10. The last common is always the COMS (common output for the icons). That means the icons will never scroll with the general display data.

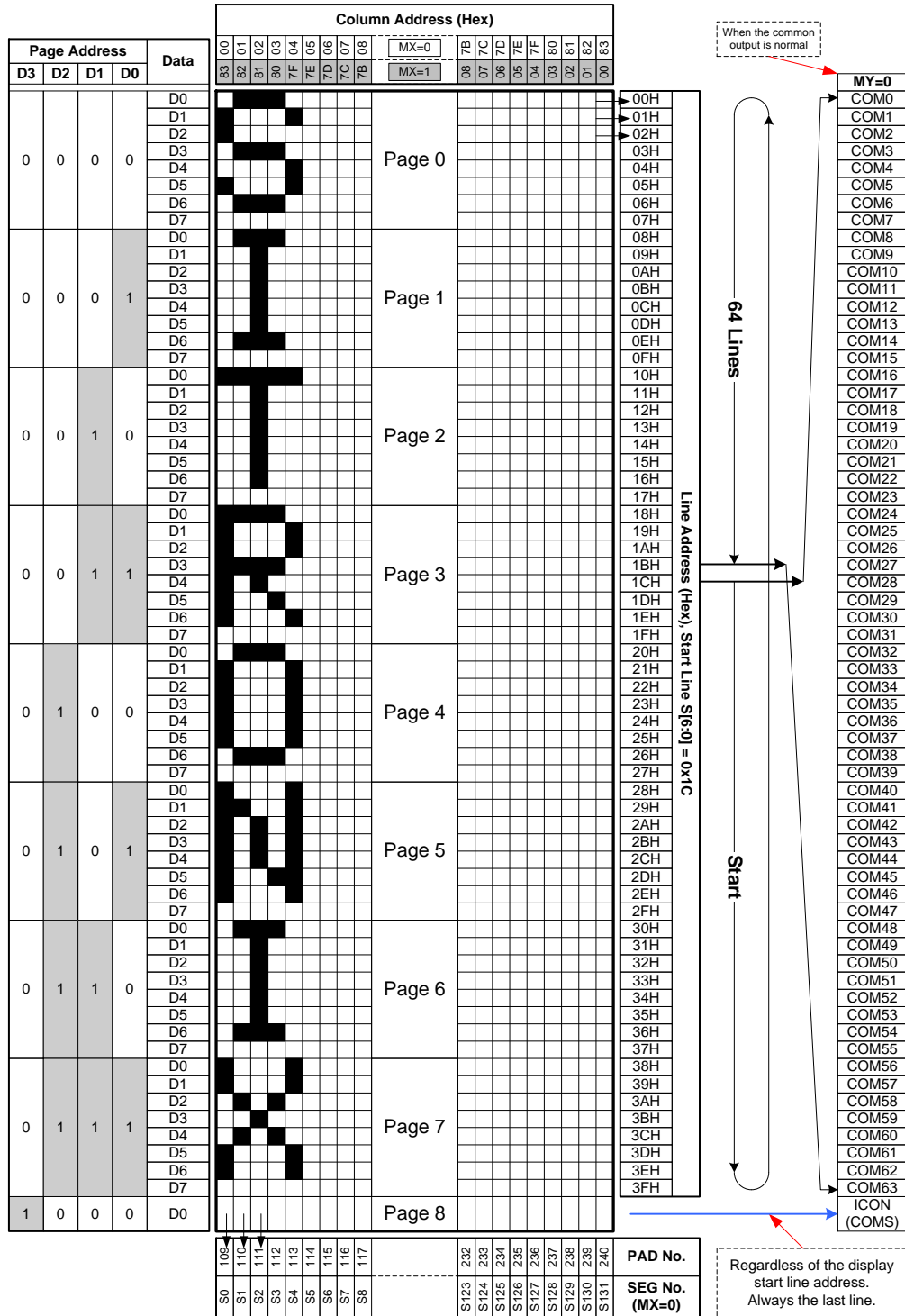

Fig 10. Start Line Function

## Display Data Latch Circuit

The display data latch circuit latches temporarily display data of each segment output which will be output at the next clock. The special functions such as reverse display, display OFF and display all points ON only change the data in the latch and the content in the Display Data RAM is not changed.

## Oscillation Circuit

The built-in oscillation circuit generates the system clock for the liquid crystal driving circuit. The oscillation circuit is enabled after initializing ST7567. The clock will not be output to reduce the power consumption.

## Liquid Crystal Driver Power Circuit

The built-in power circuits generate the voltage levels which are necessary to drive the liquid crystal. It consumes low power with the fewest external components. The built-in power system has voltage booster, voltage regulator and voltage follower circuits. Before power ST7567 OFF, a Power OFF procedure is needed (please refer to the OPERATION FLOW section).

## External Components of Power Circuit

The recommended external power components need only 2 capacitors. The detailed values of these two capacitors are determined by the panel size and loading.

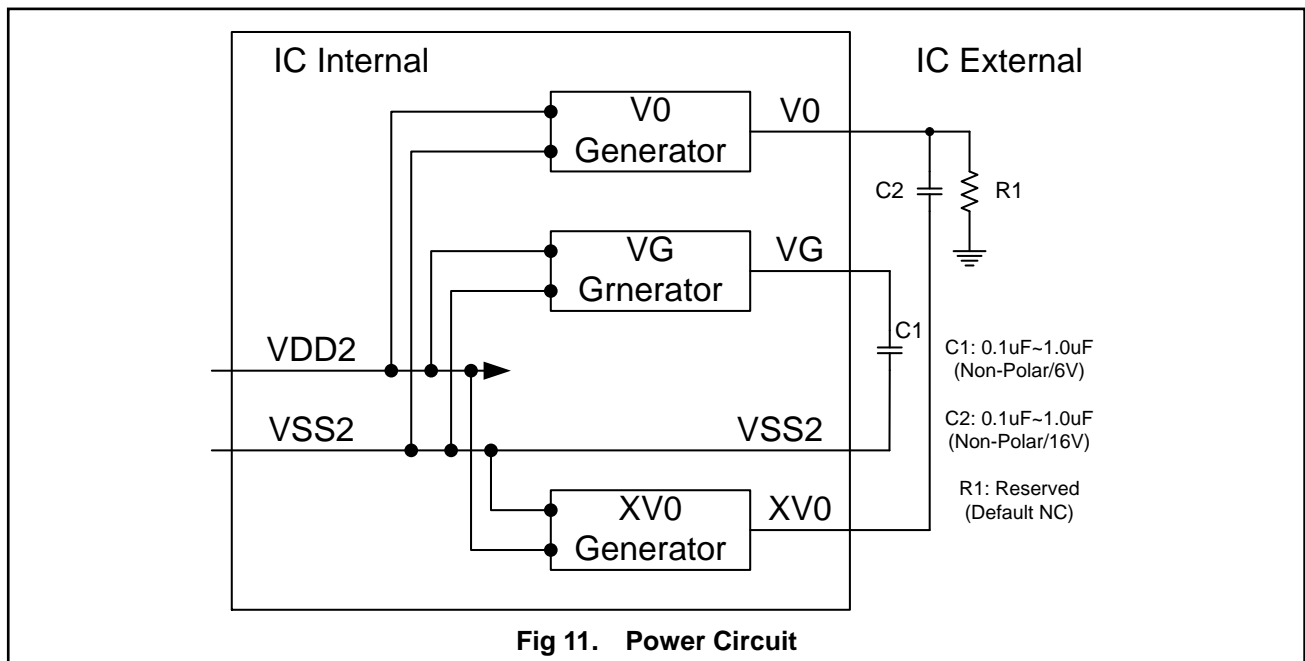

## Regulator Circuit

The built-in high accuracy regulation circuit has 8 regulation ratios and each one has 64 EV-levels for voltage adjustment. Without additional external component, the output voltage can be changed by instructions such as "Regulation Ratio" and "Set EV". The detailed setting method can be found in the INSTRUCTION DESCRIPTION section.

## RESET CIRCUIT

Setting RSTB to “L” can initialize internal function. While RSTB is “L”, no instruction except read status can be accepted. RSTB pin must connect to the reset pin of MPU and initialization by RSTB pin is essential before operating. Please note the hardware reset is not same as the software reset. When RSTB becomes “L”, the hardware reset procedure will start. When RESET instruction is executed, the software reset procedure will start. The procedure is listed below:

Procedure	Hardware Reset	Software Reset
Display OFF: D=0, all SEGs/COMs output at VSS	V	X
Normal Display: INV=0, AP=0	V	X
SEG Normal Direction: MX=0	V	X
Clear Serial Counter and Shift Register (if using Serial Interface)	V	X
Bias Selection: BS=0	V	X
Booster Level BL=0	V	X
Exit Power Saving Mode	V	X
Power Control OFF: VB=0, VR=0, VF=0	V	X
Exit Read-modify-Write mode	V	V
Start Line S[5:0]=0	V	V
Column Address X[7:0]=0	V	V
Page Address Y[3:0]=0	V	V
COM Normal Direction: MY=0	V	V
V0 Regulation Ratio RR[2:0]=(1,0,0)	V	V
EV[5:0]=(1,0,0,0,0,0)	V	V
Exit Test Mode: TE=0	V	V

After power-on, RAM data are undefined and the display status is “Display OFF”. It’s better to initialize whole DDRAM (ex: fill all 00h or write the display pattern) before turning the Display ON. Besides, the power is not stable at the time that the power is just turned ON. A hardware reset is needed to initialize those internal registers after the power is stable.

## 8. INSTRUCTION TABLE

INSTRUCTION	A0	R/W (RWR)	COMMAND BYTE								DESCRIPTION	
			D7	D6	D5	D4	D3	D2	D1	D0		
(1) Display ON/OFF	0	0	1	0	1	0	1	1	1	1	D	D=1, display ON D=0, display OFF
(2) Set Start Line	0	0	0	1	S5	S4	S3	S2	S1	S0		Set display start line
(3) Set Page Address	0	0	1	0	1	1	Y3	Y2	Y1	Y0		Set page address
(4) Set Column Address	0	0	0	0	0	1	X7	X6	X5	X4		Set column address (MSB)
	0	0	0	0	0	0	X3	X2	X1	X0		Set column address (LSB)
(5) Read Status	0	1	0	MX	D	RST	0	0	0	0		Read IC Status
(6) Write Data	1	0	D7	D6	D5	D4	D3	D2	D1	D0		Write display data to RAM
(7) Read Data	1	1	D7	D6	D5	D4	D3	D2	D1	D0		Read display data from RAM
(8) SEG Direction	0	0	1	0	1	0	0	0	0	0	MX	Set scan direction of SEG MX=1, reverse direction MX=0, normal direction
(9) Inverse Display	0	0	1	0	1	0	0	1	1	1	INV	INV =1, inverse display INV =0, normal display
(10) All Pixel ON	0	0	1	0	1	0	0	1	0	0	AP	AP=1, set all pixel ON AP=0, normal display
(11) Bias Select	0	0	1	0	1	0	0	0	1	1	BS	Select bias setting 0=1/9; 1=1/7 (at 1/65 duty)
(12) Read-modify-Write	0	0	1	1	1	0	0	0	0	0	0	Column address increment: Read:+0 , Write:+1
(13) END	0	0	1	1	1	0	1	1	1	1	0	Exit Read-modify-Write mode
(14) RESET	0	0	1	1	1	0	0	0	1	1	0	Software reset
(15) COM Direction	0	0	1	1	0	0	MY	-	-	-	-	Set output direction of COM MY=1, reverse direction MY=0, normal direction
(16) Power Control	0	0	0	0	1	0	1	VB	VR	VF		Control built-in power circuit ON/OFF
(17) Regulation Ratio	0	0	0	0	1	0	0	RR2	RR1	RR0		Select regulation resistor ratio
(18) Set EV	0	0	1	0	0	0	0	0	0	0	1	Double command!! Set electronic volume (EV) level
	0	0	0	0	EV5	EV4	EV3	EV2	EV1	EV0		
(19) Set Booster	0	0	1	1	1	1	1	1	0	0	0	Double command Set booster level: BL=0: 4X BL=1: 5X
	0	0	0	0	0	0	0	0	0	0	BL	
(20) Power Save	0	0	Compound Command									Display OFF + All Pixel ON
(21) NOP	0	0	1	1	1	0	0	0	1	1		No operation
(22) Test	0	0	1	1	1	1	1	1	1	1	TE	Test Command Moe TE=0: releasing test command mode TE=1: entering test command mode

Note: Symbol "-" means this bit can be "H" or "L".

## 9. INSTRUCTION DESCRIPTION

### Display ON/OFF

The D flag selects the display mode.

A0	R/W(RWR)	D7	D6	D5	D4	D3	D2	D1	D0
0	0	1	0	1	0	1	1	1	D

D=1: Normal Display Mode.

D=0: Display OFF. All SEGs/COMs output with VSS.

### Set Start Line

This instruction sets the line address of the Display Data RAM to determine the initial display line. The display data of the specified line address is displayed at the top row (COM0) of the LCD panel.

A0	R/W(RWR)	D7	D6	D5	D4	D3	D2	D1	D0
0	0	0	1	S5	S4	S3	S2	S1	S0

S5	S4	S3	S2	S1	S0	Line address
0	0	0	0	0	0	0
0	0	0	0	0	1	1
0	0	0	0	1	0	2
0	0	0	0	1	1	3
:	:	:	:	:	:	:
1	1	1	1	0	1	61
1	1	1	1	1	0	62
1	1	1	1	1	1	63

### Set Page Address

Y [3:0] defines the Y address vector address of the display RAM.

A0	R/W(RWR)	D7	D6	D5	D4	D3	D2	D1	D0
0	0	1	0	1	1	Y3	Y2	Y1	Y0

Y3	Y2	Y1	Y0	Page Address	Valid Bit
0	0	0	0	Page0	D0~ D7
0	0	0	1	Page1	D0~ D7
0	0	1	0	Page2	D0~ D7
:	:	:	:	:	:
0	1	1	0	Page6	D0~ D7
0	1	1	1	Page7	D0~ D7
1	0	0	0	Page8 (icon page)	D0

## Set Column Address

This instruction is used to define area of DDRAM where MCU can access. The column address is automatically increased by one after each byte of display data access (read/write). The X[7:0] setting that must be less than or equal to "83h". If X[7:0] setting is great than 83h, out of DDRAM range will be ignored.

A0	R/W(RWR)	D7	D6	D5	D4	D3	D2	D1	D0
0	0	0	0	0	1	X7	X6	X5	X4

A0	R/W(RWR)	D7	D6	D5	D4	D3	D2	D1	D0
0	0	0	0	0	0	X3	X2	X1	X0

X7	X6	X5	X4	X3	X2	X1	X0	Column address
0	0	0	0	0	0	0	0	0
0	0	0	0	0	0	0	1	1
0	0	0	0	0	0	1	0	2
0	0	0	0	0	0	1	1	3
:	:	:	:	:	:	:	:	:
1	0	0	0	0	0	0	1	129
1	0	0	0	0	0	1	0	120
1	0	0	0	0	0	1	1	131

## Read Status

Read the internal status of ST7567. The read function is not available in serial interface mode.

A0	R/W(RWR)	D7	D6	D5	D4	D3	D2	D1	D0
0	1	0	MX	D	RST	0	0	0	0

Flag	Description
MX	MX=0: Normal direction (SEG0->SEG131) MX=1: Reverse direction (SEG131->SEG0)
D	D=0: Display ON D=1: Display OFF
RST	RST=1: During reset (hardware or software reset) RST=0: Normal operation

## Write Data

8-bit data of Display Data from the microprocessor can be written to the RAM location specified by the column address and page address. The column address is increased by 1 automatically so that the microprocessor can continuously write data to the addressed page. During auto-increment, the column address wraps to 0 after the last column is written.

A0	R/W(RWR)	D7	D6	D5	D4	D3	D2	D1	D0
1	0	Write Data							

## Read Data

8-bit data of Display Data from the RAM location specified by the column address and page address can be read to the microprocessor. The read function is not available in serial interface mode.

A0	R/W(RWR)	D7	D6	D5	D4	D3	D2	D1	D0
1	1	Read Data							

## SEG Direction

A0	R/W(RWR)	D7	D6	D5	D4	D3	D2	D1	D0
0	0	1	0	1	0	0	0	0	MX

Flag	Description
MX	MX=0: Normal direction (SEG0->SEG131) MX=1: Reverse direction (SEG131->SEG0)

## Inverse Display

This instruction changes the selected and non-selected voltage of SEG. The display will be inversed (white -> Black, Black -> White) while the display data in the Display Data RAM is never changed.

A0	R/W(RWR)	D7	D6	D5	D4	D3	D2	D1	D0
0	0	1	0	1	0	0	1	1	INV

Flag	Description
INV	INV=0: Normal display INV =1: Inverse display

## All Pixel ON

This instruction will let all segments output the selected voltage and make all pixels turned ON.

A0	R/W(RWR)	D7	D6	D5	D4	D3	D2	D1	D0
0	0	1	0	1	0	0	1	0	AP

Flag	Description
AP	AP =0: Normal display AP =1: All pixels ON

## Bias Select

Select LCD bias ratio of the voltage required for driving the LCD.

A0	R/W(RWR)	D7	D6	D5	D4	D3	D2	D1	D0
0	0	1	0	1	0	0	0	1	BS

Duty	Bias	
	BS=0	BS=1
1/65	1/9	1/7
1/49	1/8	1/6
1/33	1/6	1/5
1/55	1/8	1/6

Reference LCD Bias Voltage (1/65 Duty with 1/9 Bias)

Symbol	Bias Voltage
V0	V0
VG	2/9 x V0
VM	1/9 x V0
VSS	VSS

Please Note:

\* VG range:  $1.24V \leq VG < VDD2$ .

\* VM range:  $0.62V \leq VM < VDD2$ .



## Read-modify-Write

This command is used paired with the “END” instruction. Once this command has been input, the display data read operation will not change the column address, but only the display data write operation will increase the column address ( $X[7:0]+1$ ). This mode is maintained until the END command is input. This function makes it possible to reduce the load on the MPU when there are repeating data changes in a specified display region, such as a blanking cursor.

A0	R/W(RWR)	D7	D6	D5	D4	D3	D2	D1	D0
0	0	1	1	1	0	0	0	0	0

⇒ In Read-modify-Write mode, other instructions aside from display data read/write commands can also be used.

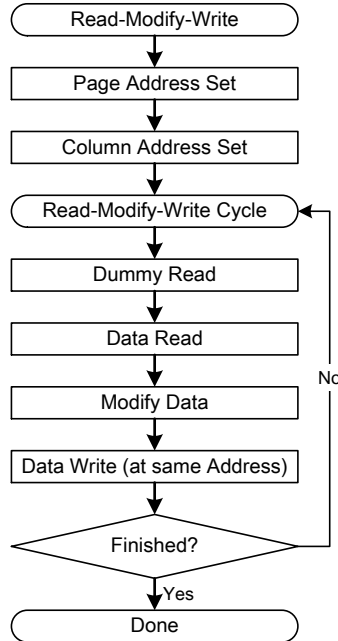

## END

When the END command is input, the Read-modify-Write mode is released and the column address returns to the address it was when the Read-modify-Write instruction was entered.

A0	R/W(RWR)	D7	D6	D5	D4	D3	D2	D1	D0
0	0	1	1	1	0	1	1	1	0

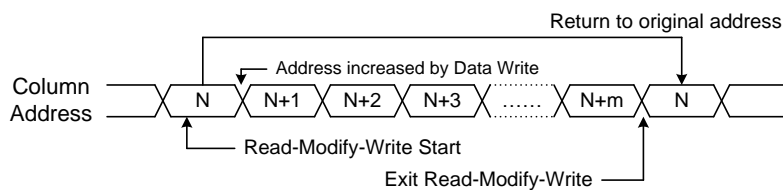

## RESET

This instruction resets Start Line (S[5:0]), Column Address (X[7:0]), Page Address (Y[3:0]) and COM Direction (MY) to their default setting. Please note this instruction is not complete same as hardware reset (RSTB=L) and cannot initialize the built-in power circuit which is initialized by the RSTB pin. The detailed information is in “Section RESET CIRCUIT”.

A0	R/W(RWR)	D7	D6	D5	D4	D3	D2	D1	D0
0	0	1	1	1	0	0	0	1	0

## COM Direction

This instruction controls the common output status which changes the vertical display direction. The detailed information can be found in Fig 9.

A0	R/W(RWR)	D7	D6	D5	D4	D3	D2	D1	D0
0	0	1	1	0	0	MY	-	-	-

Flag	Description
MY	MY=0: Normal direction (COM0->COM63) MY=1: Reverse direction (COM63->COM0)

## Power Control

This instruction controls the built-in power circuits. Typically, these 3 flags are turned ON at the same time.

A0	R/W(RWR)	D7	D6	D5	D4	D3	D2	D1	D0
0	0	0	0	1	0	1	VB	VR	VF

Flag	Description
VB	VB=0: Built-in Booster OFF VB=1: Built-in Booster ON
VR	VR=0: Built-in Regulator OFF VR=1: Built-in Regulator ON
VF	VF=0: Built-in Follower OFF VF=1: Built-in Follower ON

## Regulation Ratio

This instruction controls the regulation ratio of the built-in regulator.

A0	R/W(RWR)	D7	D6	D5	D4	D3	D2	D1	D0
0	0	0	0	1	0	0	RR2	RR1	RR0

RR2	RR1	RR0	Regulation Ratio (RR)
0	0	0	3.0
0	0	1	3.5
0	1	0	4.0
0	1	1	4.5
1	0	0	5.0
1	0	1	5.5
1	1	0	6.0
1	1	1	6.5

The operation voltage (V0) calculation formula is shown below: (RR comes from Regulation Ratio, EV comes from EV[5:0])

$$V0 = RR \times [1 - (63 - EV) / 162] \times 2.1, \text{ or } V0 = RR \times [(99 + EV) / 162] \times 2.1$$

SYMBOL	REGISTER	VALUE
RR	RR[2:0]	3, 3.5, 4, 4.5, 5, 5.5, 6 and 6.5
EV	EV[5:0]	0~63

## Set EV

This is double byte instruction. The first byte set ST7567 into EV adjust mode and the following instruction will change the EV setting. That means these 2 bytes must be used together. They control the electronic volume to adjust a suitable V<sub>0</sub> voltage for the LCD.

A0	R/W(RWR)	D7	D6	D5	D4	D3	D2	D1	D0
0	0	1	0	0	0	0	0	0	1
0	0	0	0	EV5	EV4	EV3	EV2	EV1	EV0

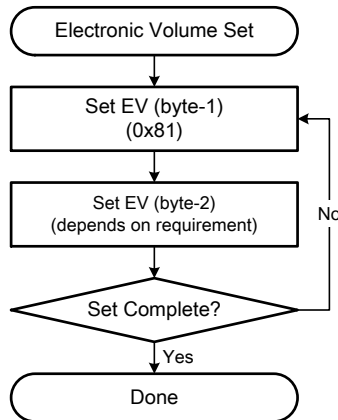

The maximum voltage that can be generated is dependent on the VDD2 voltage and the loading of LCD module. There are 8 V<sub>0</sub> voltage curve can be selected. It is recommended the EV should be close to the center (1FH) for easy contrast adjustment. Please refer to the "Selection of Application Voltage" section for detailed information.

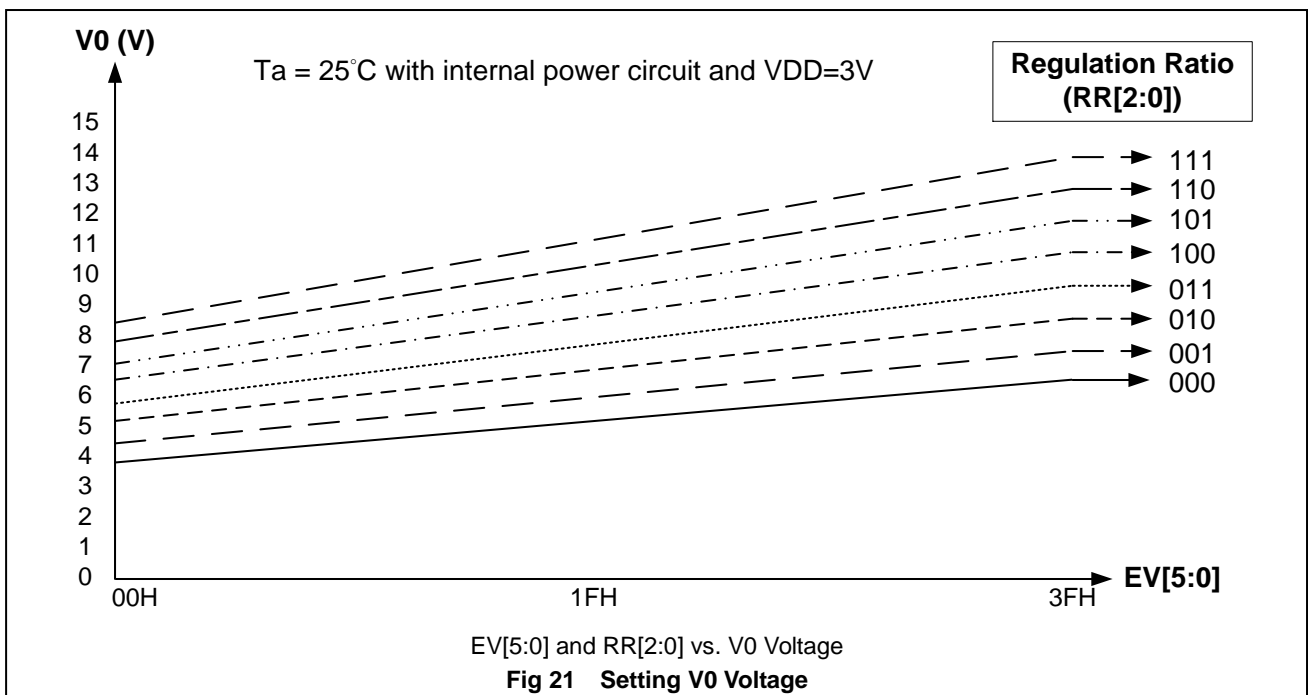

## Power Save (Compound Instruction)

This is compound instruction. The 1<sup>st</sup> instruction is Display OFF (D=0) and the 2<sup>nd</sup> instruction is All Pixel ON (AP=1). The Power Save mode starts the following procedure: (the display data and register settings are still kept except D-Flag and AP-Flag)

1. Stops internal oscillation circuit;
2. Stops the built-in power circuits;
3. Stops the LCD driving circuits and keeps the common and segment outputs at VSS.

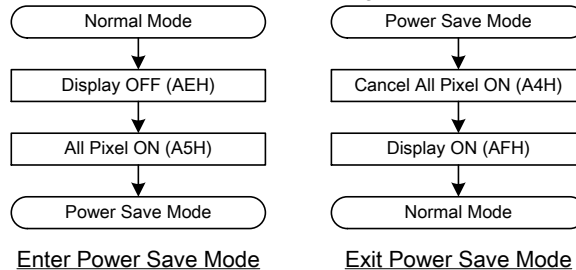

After exiting Power Save mode, the settings will return to be as they were before.

## Set Booster

This is double byte instruction. The first byte set ST7567 into booster configuration mode and the following instruction will change the booster setting. That means these 2 bytes must be used together. They control the built-in booster circuit to provide the power source of the built-in regulator. ST7567 booster is built-in booster capacitors. The only external component is a keep capacitor between V0 and XV0. Booster level can be changed with instruction only without changing hardware connection.

A0	R/W(RWR)	D7	D6	D5	D4	D3	D2	D1	D0
0	0	1	1	1	1	1	0	0	0
0	0	0	0	0	0	0	0	0	BL

BL	Boost Level
0	X4
1	X5

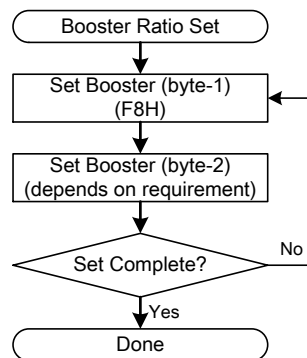

## NOP

“No Operation” instruction. ST7567 will do nothing when receiving this instruction.

A0	R/W(RWR)	D7	D6	D5	D4	D3	D2	D1	D0
0	0	1	1	1	0	0	0	1	1

## Test

The test mode is reserved for IC testing. Please don't use this instruction. If the test mode is enabled accidentally, it can be cleared by: issuing TE=0 instruction or issuing an “L” pulse on RSTB pin.

A0	R/W(RWR)	D7	D6	D5	D4	D3	D2	D1	D0
0	0	1	1	1	1	1	1	1	TE

Flag	Description
TE	TE=0: Disable Test Command Mode. TE=1: Enable Test Command Mode.

## 10. OPERATION FLOW

This section introduces some reference operation flows.

### Power ON

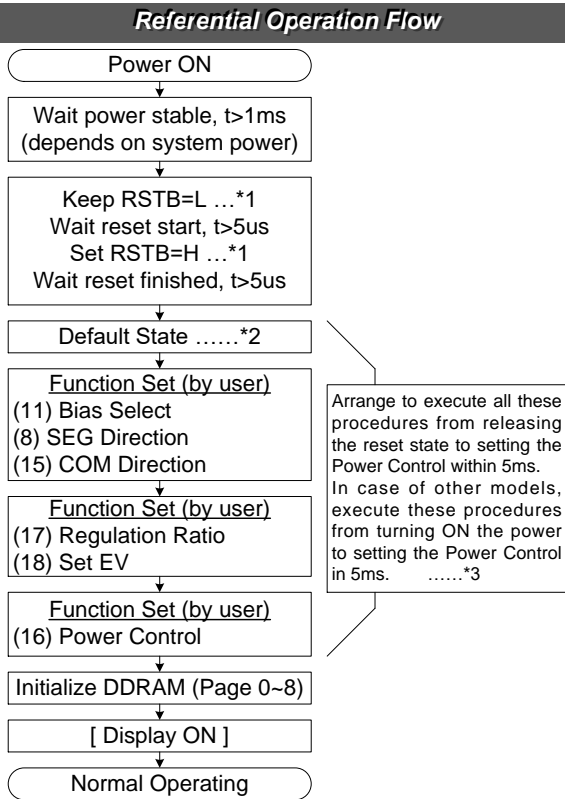

### Operation Sequence

#### Case 1: RSTB=L while Power ON

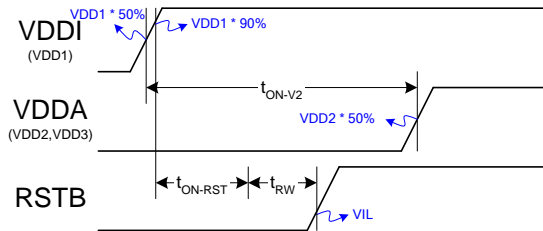

#### Case 2: RSTB=H while Power ON

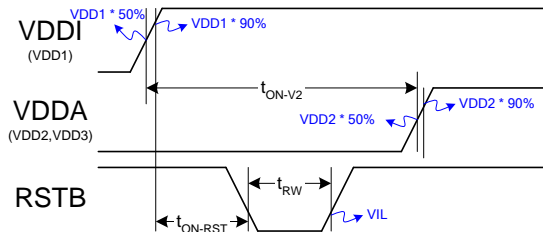

Note: The detailed description can be found in the respective sections listed below.

1. Please refer to the timing specification of  $t_{RW}$  and  $t_R$ .
2. Refer to Section RESET CIRCUIT.
3. The 5ms requirement depends on the characteristics of LCD panel and the external component of the power circuit. It is recommended to check with the real products with external component.
4. The detailed instruction functionality is described in Section 9. INSTRUCTION DESCRIPTION;
5. Power stable is defined as the time that the later power (VDDI or VDDA) reaches 90% of its rated voltage.

Timing Requirement:

Item	Symbol	Requirement	Note
VDDA power delay	$t_{ON-V2}$	$0 \leq t_{ON-V2}$	<ul style="list-style-type: none"> <li>● Applying VDDI and VDDA in any order will not damage IC.</li> </ul>
RSTB input time	$t_{ON-RST}$	No Limitation	<ul style="list-style-type: none"> <li>● If RSTB is Low, High or unstable during power ON, a successful hardware reset by RSTB is required after VDDI is stable.</li> <li>● RSTB=L can be input at any time after power is stable.</li> <li>● <math>t_{RW}</math> &amp; <math>t_R</math> should match the timing specification of RSTB.</li> <li>● To prevent abnormal display, the recommended timing is: <math>0 \leq t_{ON-RST} \leq 30</math> ms.</li> </ul>

- The requirement listed here is to prevent abnormal display on LCD module.

## Display Data

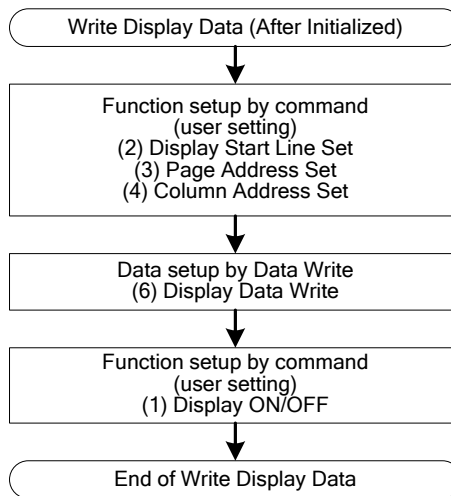

Notes: Reference items

1. The detailed instruction functionality is described in Section 9. INSTRUCTION DESCRIPTION;
2. It is recommended to write display data (initialize DDRAM) before Display ON.

## Refresh

It is recommended to use the refresh sequence regularly in a specified interval.

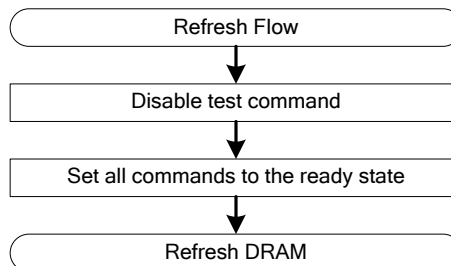

## Power-Save Flow and Sequence

### ENTERING THE POWER SAVE MODE

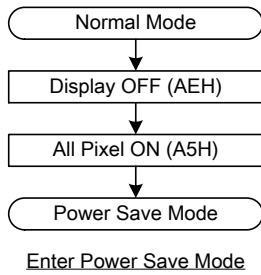

### EXITING THE POWER SAVE MODE

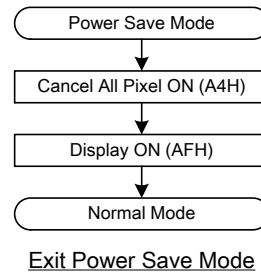

### INTERNAL SEQUENCE of EXIT POWER SAVE MODE

After receiving "PD=0", the internal circuits (Power) will starts the following procedure.

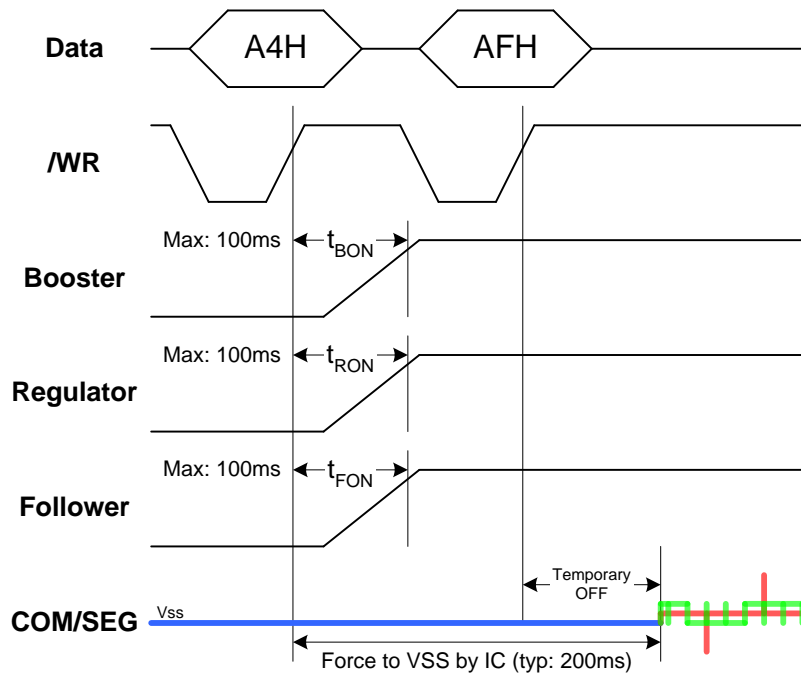

Note:

1. The power stable time is determined by LCD panel loading.
2. The power stable time in this figure is base on: LCD Panel Size = 1.4" with C1=1uF, C2=1uF (VDD=2.7V, Vop=9V).

## Power OFF Flow and Sequence

In power save mode, LCD outputs are fixed to VSS and all analog outputs are discharged. The power can be turned OFF after ST7567 is in the power save mode. The power save mode can be triggered by the following two methods.

Referential Power OFF Flow	Operation Sequence
CASE 1: Use Power Save Instruction	

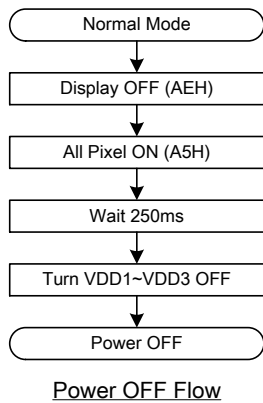

### Instruction Flow

After the built-in power circuits are OFF and completely discharged, the power (VDDI, VDDA) can be removed.

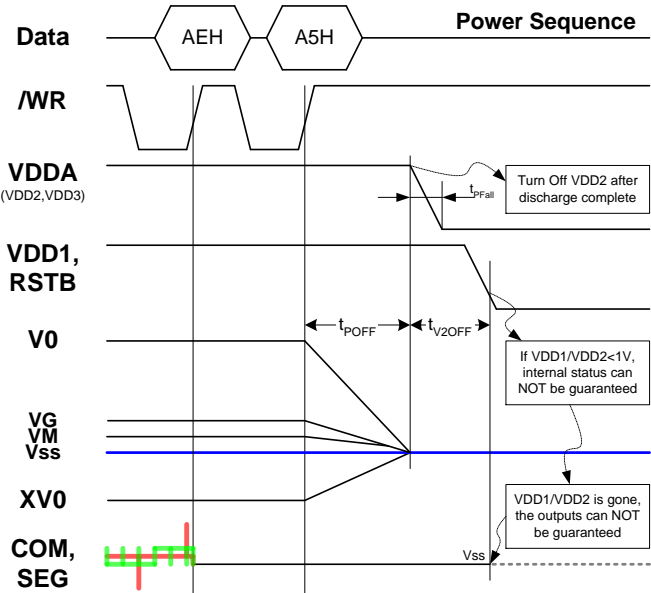

### CASE 2: Use Hardware Reset Function

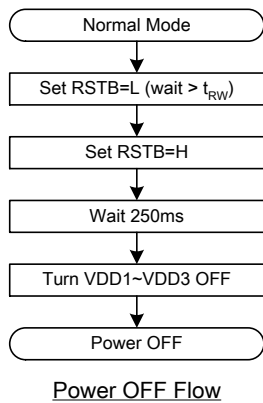

### Instruction Flow

After the built-in power circuits are OFF and completely discharged, the power (VDDI, VDDA) can be removed.

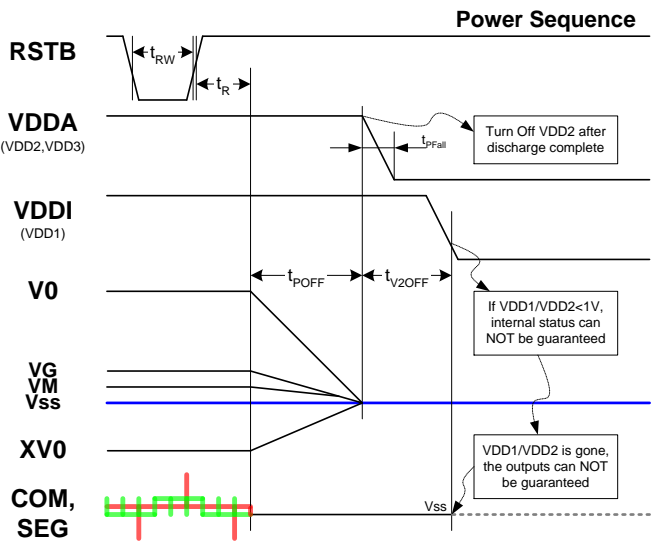

Note:

1.  $t_{POFF}$ : Internal Power discharge time. => 250ms (max).
2.  $t_{V2OFF}$ : Period between VDDI and VDDA OFF time. => 0 ms (min).
3. It is NOT recommended to turn VDDI OFF before VDDA. Without VDDI, the internal status cannot be guaranteed and internal discharge-process maybe stopped. The un-discharged power maybe flows into COM/SEG output(s) and the liquid crystal in panel maybe polarized.
4. IC will NOT be damaged if either VDDI or VDDA is OFF while another is ON.
5. The timing is dependent on panel loading and the external capacitor(s).
6. The timing in these figures is base on the condition that: LCD Panel Size = 1.4" with  $C1=1\mu F$ ,  $C2=1\mu F$ .
7. When turning VDDA OFF, the falling time should follow the specification:  
 $20ms \leq t_{Pfall} \leq 0.2sec$



## 11. ABSOLUTE MAXIMUM RATINGS

In accordance with the Absolute Maximum Rating System; please refer to notes 1 and 2.

Parameter	Symbol	Conditions	Unit
Digital Power Supply Voltage	VDD1	-0.3 ~ 4.0	V
Analog Power supply voltage	VDD2, VDD3	-0.3 ~ 4.0	V
LCD Power supply voltage	V0-XV0	-0.3 ~ 16	V
LCD Power supply voltage	VG	-0.3 ~ 4.0	V
Input Voltage	VIN	-0.3 ~ VDD1+0.3	V
Operating temperature	TOPR	-30 to +85	°C
Storage temperature	TSTR	-55 to +125	°C

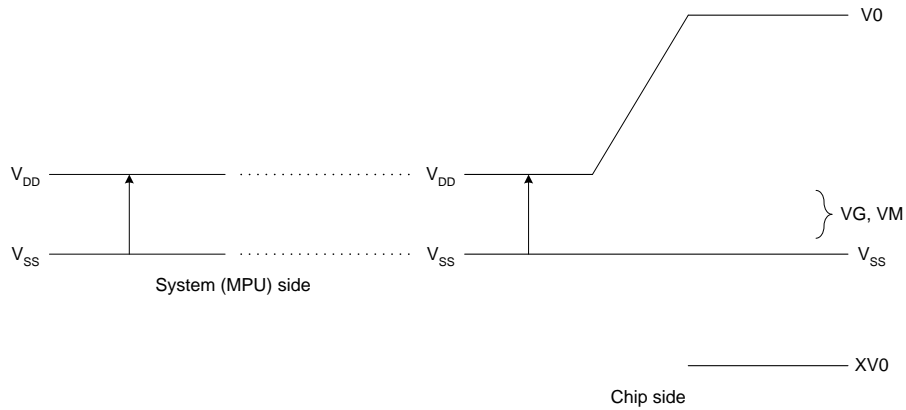

### Notes

- Parameters are valid over operating temperature range unless otherwise specified. All voltages are with respect to VSS unless otherwise noted.
- Insure the voltage levels of V<sub>0</sub>, VDD2, VG, VM, VSS and XV0 always match the correct relation:  
 $V_0 \geq VDD2 > VG > VM > VSS \geq XV0$
- That the stress exceeds the Limiting Value listed above it may cause the driver IC permanent damage. These values are for stress only. IC should be operated under the DC/Timing Characteristic conditions for normal operation. If these conditions are not met, IC operation may be error and the reliability may be deteriorated.
- VIN should be less than or equal to 3.6V. ( $VIN \leq 3.6V$ )

## 12. HANDLING

Inputs and outputs are protected against electrostatic discharge in normal handling. However, to be totally safe, it is desirable to take normal precautions appropriate to handling MOS devices.

## 13. DC CHARACTERISTICS

VSS=0V; Tamb = -30°C to +85°C; unless otherwise specified.

Item	Symbol	Condition		Rating			Unit	Applicable Pin
				Min.	Typ.	Max.		
Operating Voltage (1)	VDD1			1.7	—	3.6	V	VDD1
Operating Voltage (2)	VDD2			2.4	—	3.6	V	VDD2
Operating Voltage (3)	VDD3			2.4	—	3.6	V	VDD3
Input High-level Voltage	V <sub>IHC</sub>			0.7 x VDD1	—	VDD1	V	MPU Interface
Input Low-level Voltage	V <sub>ILC</sub>			VSS1	—	0.3 x VDD1	V	MPU Interface
Output High-level Voltage	V <sub>OHC</sub>	I <sub>OUT</sub> =1mA, VDD1=1.8V		0.8 x VDD1	—	VDD1	V	D[7:0]
Output Low-level Voltage	V <sub>OLC</sub>	I <sub>OUT</sub> =-1mA, VDD1=1.8V		VSS1	—	0.2 x VDD1	V	D[7:0]
Input Leakage Current	I <sub>LI</sub>			-1.0	—	1.0	μA	MPU Interface
Output Leakage Current	I <sub>LO</sub>			-3.0	—	3.0	μA	MPU Interface
Liquid Crystal Driver ON Resistance	R <sub>ON</sub>	Ta=25°C	V <sub>op</sub> =8.5V, ΔV=0.85V	—	0.6	0.8	KΩ	COMx
			V <sub>G</sub> =1.9V, ΔV=0.19V	—	1.3	1.5	KΩ	SEGx
Frame Frequency	FR	Duty=1/65, V <sub>op</sub> =8.5V Ta = 25°C		70	75	80	Hz	

Current consumption: During Display, with internal power system, current consumed by whole IC (bare die).

Test Pattern	Symbol	Condition	Rating			Unit	Note
			Min.	Typ.	Max.		
Display Pattern: SNOW (Static)	ISS	VDD1=VDD2=VDD3=3.0V, Booster X5 $V_{OP} = 8.5\text{ V}$ , Bias=1/9 $T_a=25^\circ\text{C}$	—	150	300	$\mu\text{A}$	
Display OFF	ISS	VDD1=VDD2=VDD3=3.0V, Booster X5 $V_{OP} = 8.5\text{ V}$ , Bias=1/9 $T_a=25^\circ\text{C}$	—	95	190	$\mu\text{A}$	
Power Down	ISS	VDD1=VDD2=VDD3=3.0V, $T_a=25^\circ\text{C}$	—	8	16	$\mu\text{A}$	

Note:

- *The Current Consumption is DC characteristics*

## 14. TIMING CHARACTERISTICS

### System Bus Timing for 6800 Series MPU

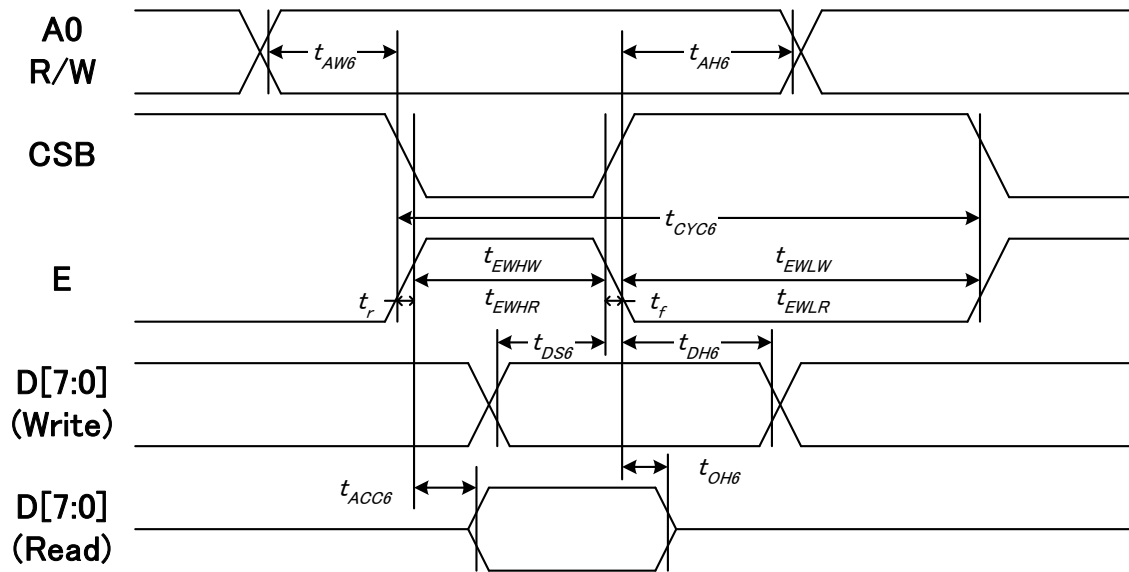

(VDD1 = 3.3V , Ta =25°C)

Item	Signal	Symbol	Condition	Min.	Max.	Unit
Address setup time	A0	tAW6		0	—	ns
Address hold time		tAH6		10	—	
System cycle time	E	tCYC6		240	—	
Enable L pulse width (WRITE)		tEHLW		80	—	
Enable H pulse width (WRITE)		tEHWLW		80	—	
Enable L pulse width (READ)		tEHLR		80	—	
Enable H pulse width (READ)	tEHWHR		140	—		
Write data setup time	D[7:0]	tDS6		40	—	
Write data hold time		tDH6		10	—	
Read data access time	D[7:0]	tACC6	CL = 16 pF	—	70	
Read data output disable time		tOH6	CL = 16 pF	5	50	

(VDD1 = 2.8V , Ta =25°C)

Item	Signal	Symbol	Condition	Min.	Max.	Unit
Address setup time	A0	tAW6		0	—	ns
Address hold time		tAH6		0	—	
System cycle time	E	tCYC6		400	—	
Enable L pulse width (WRITE)		tEHLW		220	—	
Enable H pulse width (WRITE)		tEHWLW		180	—	
Enable L pulse width (READ)		tEHLR		220	—	
Enable H pulse width (READ)	tEHWHR		180	—		
Write data setup time	D[7:0]	tDS6		40	—	
Write data hold time		tDH6		20	—	
Read data access time	D[7:0]	tACC6	CL = 16 pF	—	140	
Read data output disable time		tOH6	CL = 16 pF	10	100	

(VDD1 = 1.8V , Ta =25°C)

Item	Signal	Symbol	Condition	Min.	Max.	Unit
Address setup time	A0	tAW6		0	—	ns
Address hold time		tAH6		0	—	
System cycle time	E	tCYC6		640	—	
Enable L pulse width (WRITE)		tEWLW		360	—	
Enable H pulse width (WRITE)		tEWHW		280	—	
Enable L pulse width (READ)		tEWLR		360	—	
Enable H pulse width (READ)		tEWHR		280	—	
Write data setup time		D[7:0]	tDS6		80	
Write data hold time	tDH6			20	—	
Read data access time	tACC6		CL = 16 pF	—	240	
Read data output disable time	tOH6		CL = 16 pF	10	200	

\*1 The input signal rise time and fall time (tr, tf) is specified at 15 ns or less. When the system cycle time is extremely fast, (tr + tf) ≤ (tCYC6 - tEWLW - tEWHW) for (tr + tf) ≤ (tCYC6 - tEWLR - tEWHR) are specified.

\*2 All timing is specified using 20% and 80% of VDD1 as the reference.

\*3 tEWLW and tEWLR are specified as the overlap between CSB being “L” and E.

## System Bus Timing for 8080 Series MPU

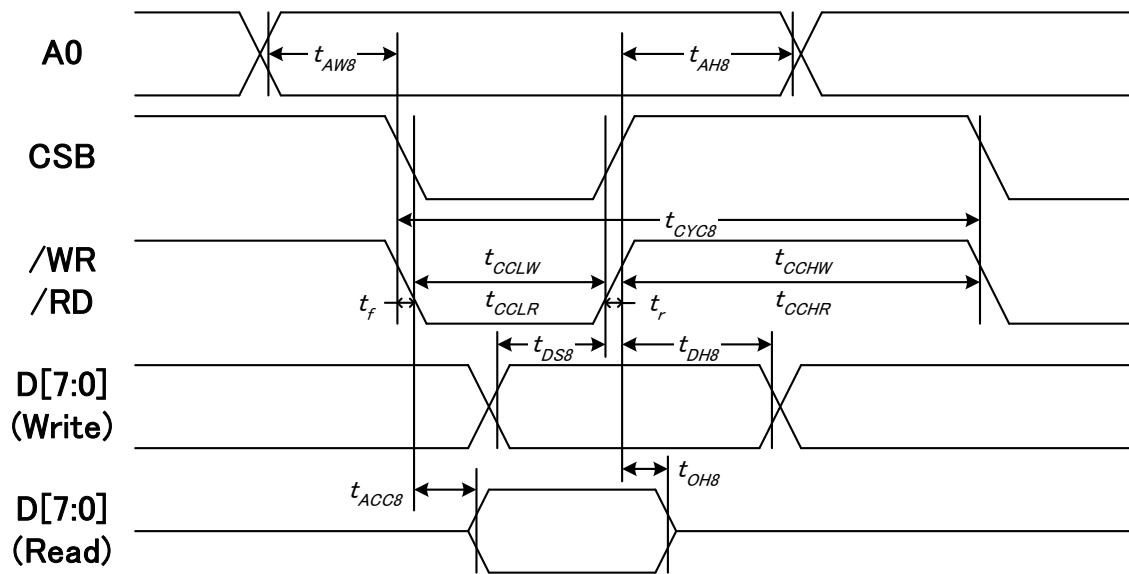

(VDD1 = 3.3V , Ta =25°C)

Item	Signal	Symbol	Condition	Min.	Max.	Unit
Address setup time	A0	tAW8		0	—	ns
Address hold time		tAH8		10	—	
System cycle time	/WR	tCYC8		240	—	
/WR L pulse width (WRITE)		tCCLW		80	—	
/WR H pulse width (WRITE)	RD	tCCHW		80	—	
/RD L pulse width (READ)		tCCLR		140	—	
/RD H pulse width (READ)	tCCHR		80	—		
WRITE Data setup time	D[7:0]	tDS8		40	—	
WRITE Data hold time		tDH8		20	—	
READ access time	D[7:0]	tACC8	CL = 16 pF	—	70	
READ Output disable time		tOH8	CL = 16 pF	5	50	

(VDD1 = 2.8V , Ta =25°C)

Item	Signal	Symbol	Condition	Min.	Max.	Unit
Address setup time	A0	tAW8		0	—	ns
Address hold time		tAH8		0	—	
System cycle time	/WR	tCYC8		400	—	
/WR L pulse width (WRITE)		tCCLW		220	—	
/WR H pulse width (WRITE)	RD	tCCHW		180	—	
/RD L pulse width (READ)		tCCLR		220	—	
/RD H pulse width (READ)	tCCHR		180	—		
WRITE Data setup time	D[7:0]	tDS8		40	—	
WRITE Data hold time		tDH8		20	—	
READ access time	D[7:0]	tACC8	CL = 16 pF	—	140	
READ Output disable time		tOH8	CL = 16 pF	10	100	

(VDD1 = 1.8V , Ta =25°C)

Item	Signal	Symbol	Condition	Min.	Max.	Unit
Address setup time	A0	tAW8		0	—	ns
Address hold time		tAH8		0	—	
System cycle time	/WR	tCYC8		640	—	
/WR L pulse width (WRITE)		tCCLW		360	—	
/WR H pulse width (WRITE)		tCCHW		280	—	
/RD L pulse width (READ)	RD	tCCLR		360	—	
/RD H pulse width (READ)		tCCHR		280	—	
WRITE Data setup time	D[7:0]	tDS8		80	—	
WRITE Data hold time		tDH8		20	—	
READ access time		tACC8	CL = 16 pF	—	240	
READ Output disable time		tOH8	CL = 16 pF	10	200	

\*1 The input signal rise time and fall time (tr, tf) is specified at 15 ns or less. When the system cycle time is extremely fast, (tr + tf) ≤ (tCYC8 - tCCLW - tCCHW) for (tr + tf) ≤ (tCYC8 - tCCLR - tCCHR) are specified.

\*2 All timing is specified using 20% and 80% of VDD1 as the reference.

\*3 tCCLW and tCCLR are specified as the overlap between CSB being “L” and WR and RD being at the “L” level.

# ST7567

## System Bus Timing for 4-Line Serial Interface

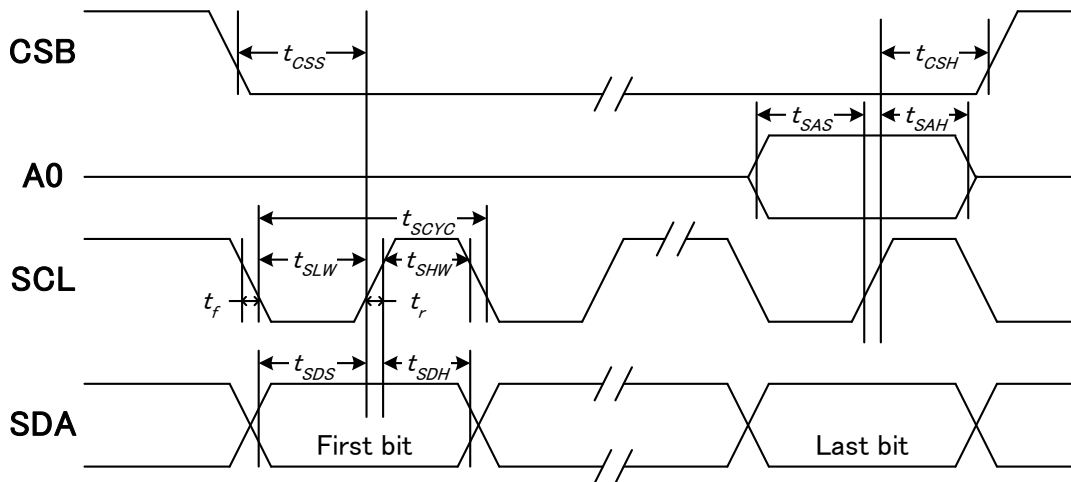

(VDD1 = 3.3V, Ta = 25°C)

Item	Signal	Symbol	Condition	Min.	Max.	Unit
Serial clock period	SCLK	tSCYC		50	—	ns
SCLK "H" pulse width		tSHW		25	—	
SCLK "L" pulse width		tSLW		25	—	
Address setup time	A0	tSAS		20	—	
Address hold time		tSAH		10	—	
Data setup time	SDA	tSDS		20	—	
Data hold time		tSDH		10	—	
CSB-SCLK time	CSB	tCSS		20	—	
CSB-SCLK time		tCSH		40	—	

(VDD1 = 2.8V, Ta = 25°C)

Item	Signal	Symbol	Condition	Min.	Max.	Unit
Serial clock period	SCLK	tSCYC		100	—	ns
SCLK "H" pulse width		tSHW		50	—	
SCLK "L" pulse width		tSLW		50	—	
Address setup time	A0	tSAS		30	—	
Address hold time		tSAH		20	—	
Data setup time	SDA	tSDS		30	—	
Data hold time		tSDH		20	—	
CSB-SCLK time	CSB	tCSS		30	—	
CSB-SCLK time		tCSH		60	—	



(VDD1 = 1.8V , Ta =25°C)

Item	Signal	Symbol	Condition	Min.	Max.	Unit
Serial clock period	SCLK	tSCYC		200	—	ns
SCLK "H" pulse width		tSHW		80	—	
SCLK "L" pulse width		tSLW		80	—	
Address setup time	A0	tSAS		60	—	
Address hold time		tSAH		30	—	
Data setup time	SDA	tSDS		60	—	
Data hold time		tSDH		30	—	
CSB-SCLK time	CSB	tCSS		40	—	
CSB-SCLK time		tCSH		100	—	

\*1 The input signal rise and fall time (tr, tf) are specified at 15 ns or less.

\*2 All timing is specified using 20% and 80% of VDD1 as the standard.

## Hardware Reset Timing

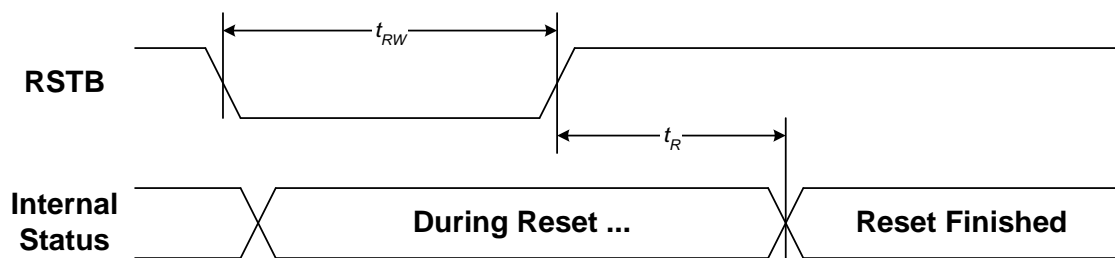

(VDD1 = 3.3V , Ta =25°C)

Item	Symbol	Condition	Min.	Max.	Unit
Reset time	tR		—	1.0	us
Reset "L" pulse width	tRW		1.0	—	

(VDD1 = 2.8V , Ta =25°C)

Item	Symbol	Condition	Min.	Max.	Unit
Reset time	tR		—	2.0	us
Reset "L" pulse width	tRW		2.0	—	

(VDD1 = 1.8V , Ta =25°C)

Item	Symbol	Condition	Min.	Max.	Unit
Reset time	tR		—	3.0	us
Reset "L" pulse width	tRW		3.0	—	

## APPLICATION NOTE

### Application Circuits

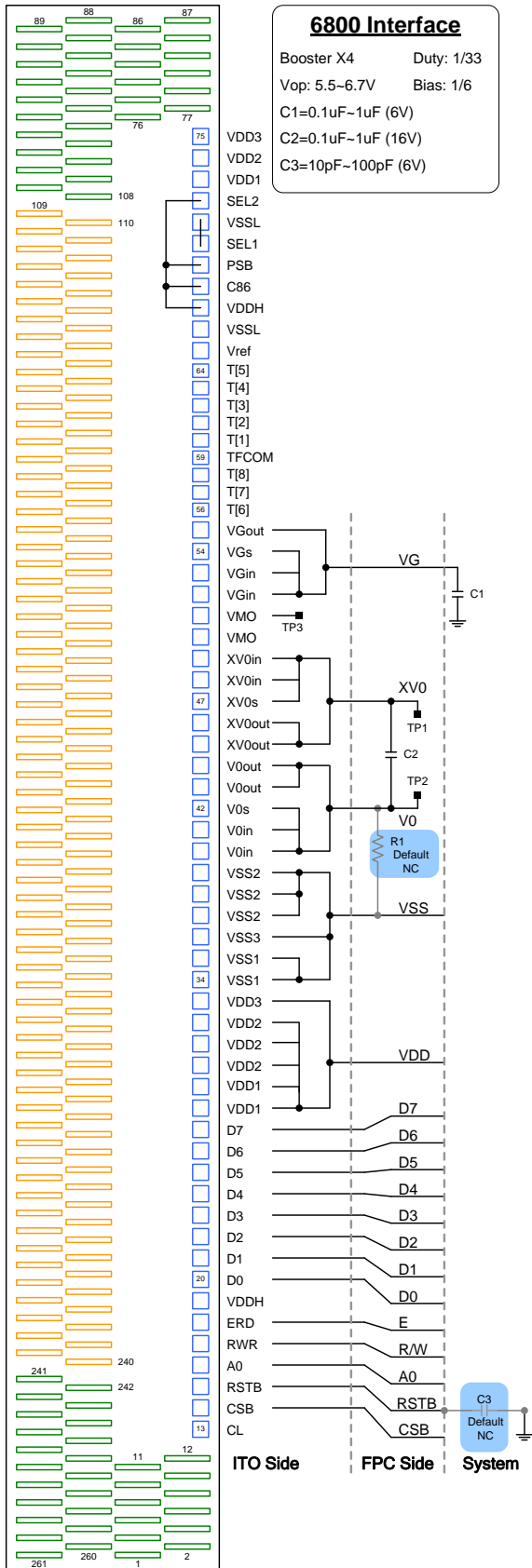

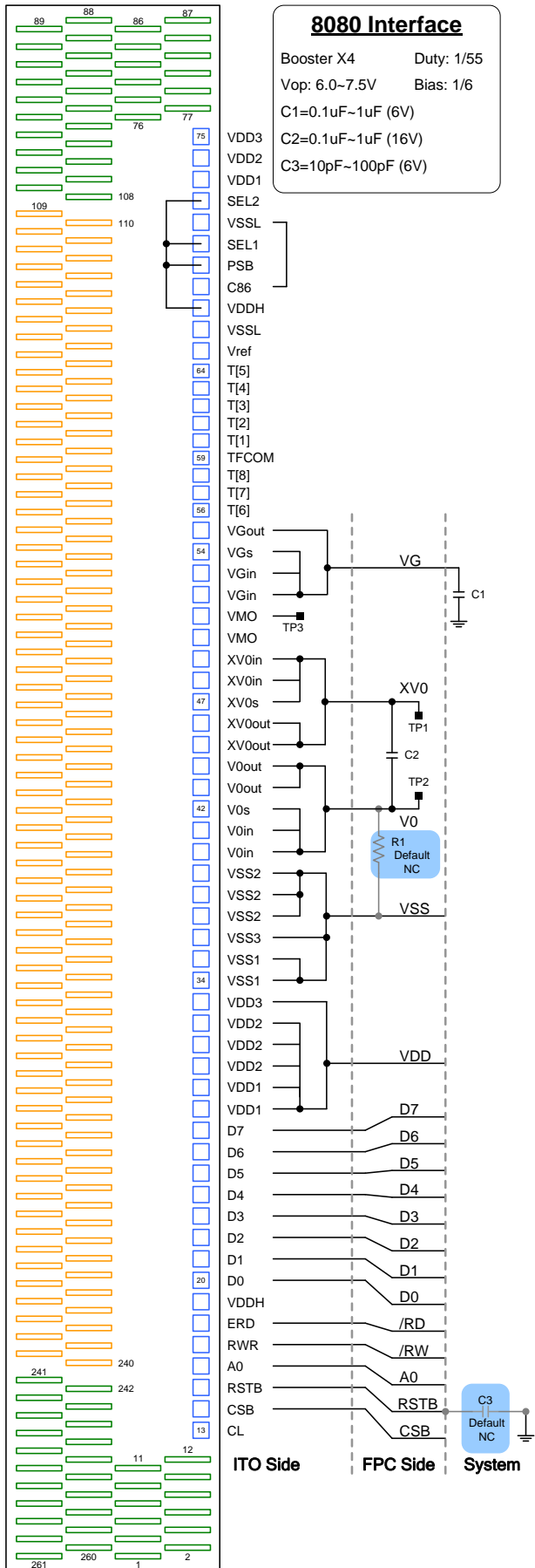

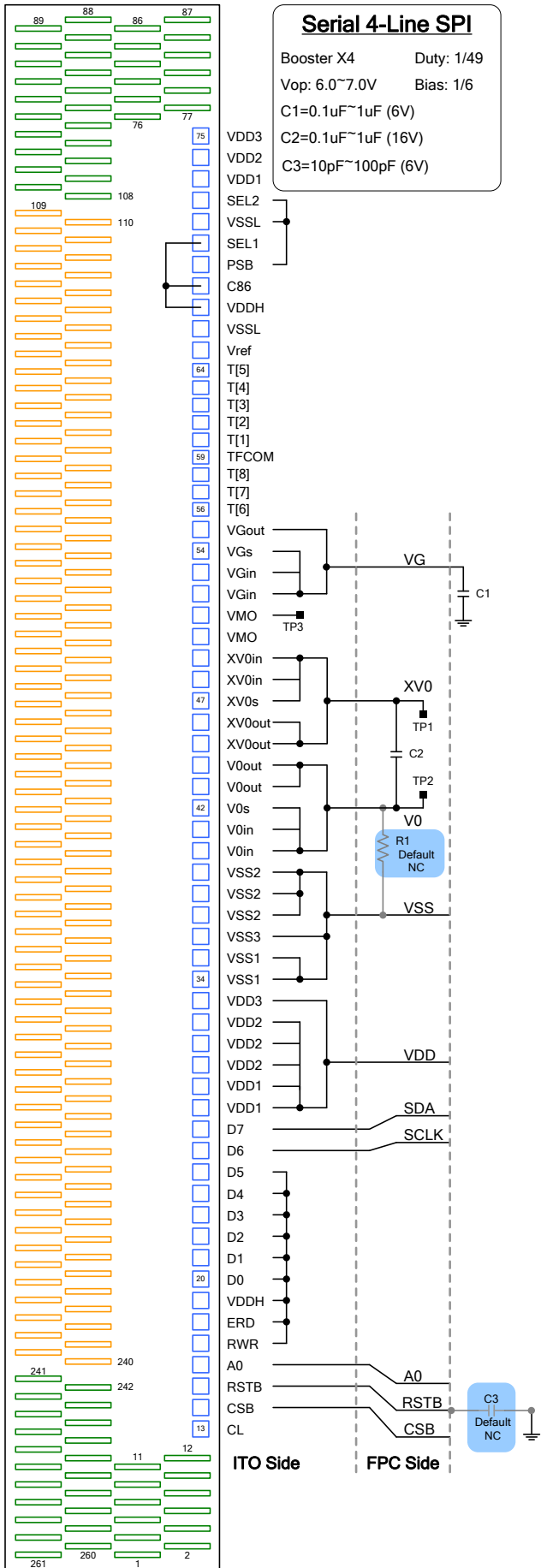

## Selection of Application Voltage

### Referential LCD Module Setting

VDD1=2.8V, VDD2=VDD3=2.8V, Panel Size=1.4", Ta=25°C

Duty	Booster	Vop	Bias
1/65	X5	8.5 ~ 9.5	1/9
		6.5 ~ 7.5	1/7
1/55	X5	7.5 ~ 8.5	1/8
		5.5 ~ 6.5	1/6
1/49	X5	7.5 ~ 8.5	1/8
		5.5 ~ 6.5	1/6
1/33	X5	5.5 ~ 6.5	1/6
		4.5 ~ 5.5	1/5

- It is recommended to reserve some range for user adjustment and temperature effect.

### Note:

- Positive Booster:  $(VDD2 \times BL \times BE) \geq V0$  or  $(VDD2 \times BL \times BE) \geq Vop$ ;
- Negative Booster:  $[-VDD2 \times (BL - 1) \times BE] \leq XV0$  or  $[VDD2 \times (BL - 1) \times BE] \geq (Vop - VG)$ ,  
where  $VG = Vop \times 2 / N$ ;
- Vop requirement:  $[VDD2 \times (BL - 1) \times BE] \geq [Vop \times (N - 2) / N]$  or  $[Vop \leq VDD2 \times (BL - 1) \times BE \times N / (N - 2)]$ .
- BL is the booster stage and BE is the booster efficiency. Referential values are listed below: (assume VDD2=VDD3=2.8V)  
Module Size  $\leq 1.4"$ : BE=80% (Typical);  
Module Size = 1.4"~1.8": BE=76% (Typical).  
Actual BE should be determined by module loading and ITO resistance value.
- $1.6 \leq VG < VDD2$ . Recommend VG is: VDD2-VG around 0.5~0.8V.
- $VM=VG/2$  and  $0.8V \leq VM < VDD2$ .
- The worse condition should be considered:  
Low temperature effect and display on with snow pattern on panel (max: 1.8").

## ITO Layout Reference

The reference ITO layout is shown below:

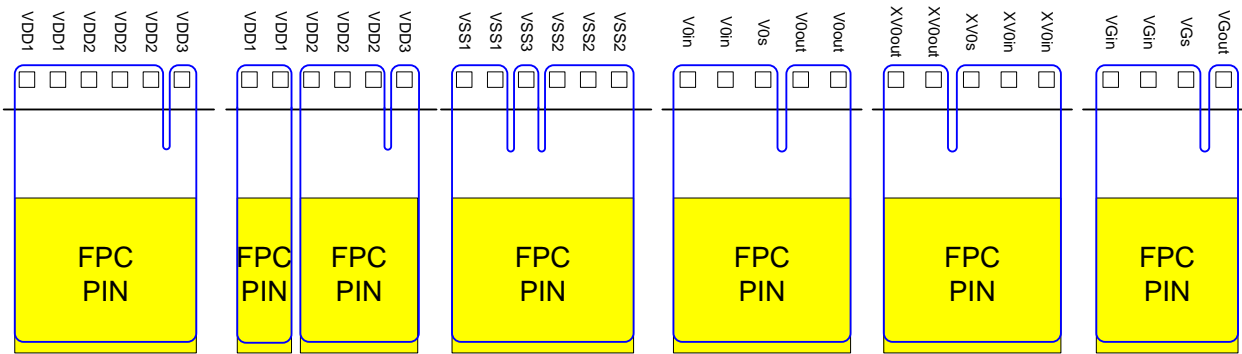

**Single VDD:** VDDI and VDDA together

**Dual VDD:** VDDI and VDDA separately

The equivalent circuit is shown below:

$V_0, XV_0$ & $V_G$	VDD (VDDI & VDDA together)	VDD (VDDI & VDDA separately)
<p><b>Ideal Layout:</b> =&gt; <math>R_4=0</math> Ohm. <math>R_2 \geq R_1 &gt; R_3</math>.</p> <p><b>Acceptable Layout:</b> =&gt; <math>R_4 \neq 0</math>. <math>R_2 \geq R_1 &gt; R_3 &gt; R_4</math>.</p> <p><b>Not Acceptable:</b> =&gt; <math>R_4 \geq (R_1 \text{ or } R_2 \text{ or } R_3)</math>.</p>	<p><b>Ideal Layout:</b> =&gt; <math>R_3=0</math> Ohm. <math>R_1 \geq R_2</math>.</p> <p><b>Acceptable Layout:</b> =&gt; <math>R_3 \neq 0</math>. <math>R_1 \geq R_2 &gt; R_3</math>.</p> <p><b>Not Acceptable:</b> =&gt; <math>R_3 \geq (R_1 \text{ or } R_2)</math>.</p>	<p><b>Ideal Layout:</b> =&gt; <math>R_4=0</math> &amp; <math>R_5=0</math> Ohm. <math>R_2 \geq R_1 &gt; R_3</math>.</p> <p><b>Acceptable Layout:</b> =&gt; <math>R_4 \neq 0</math> &amp; <math>R_5 \neq 0</math>. <math>R_2 \geq R_1 &gt; R_3 &gt; R_5 &gt; R_4</math></p> <p><b>Not Acceptable:</b> =&gt; <math>R_4</math> &amp; <math>R_5 \geq (R_1 \text{ or } R_2 \text{ or } R_3)</math>.</p>

VSS
<p><b>Ideal Layout:</b> =&gt; <math>R_4=0</math> Ohm. <math>R_2 \geq R_1 &gt; R_3</math>.</p> <p><b>Acceptable Layout:</b> =&gt; <math>R_4 \neq 0</math>. <math>R_2 \geq R_1 &gt; R_3 &gt; R_4</math>.</p> <p><b>Not Acceptable:</b> =&gt; <math>R_4 \geq (R_1 \text{ or } R_2 \text{ or } R_3)</math>.</p>

## ITO Layout Guide

The reference ITO layout is shown below:

### IC Face Down

Interface: 8080  
6800  
SPI-4  
Duty: 1/65

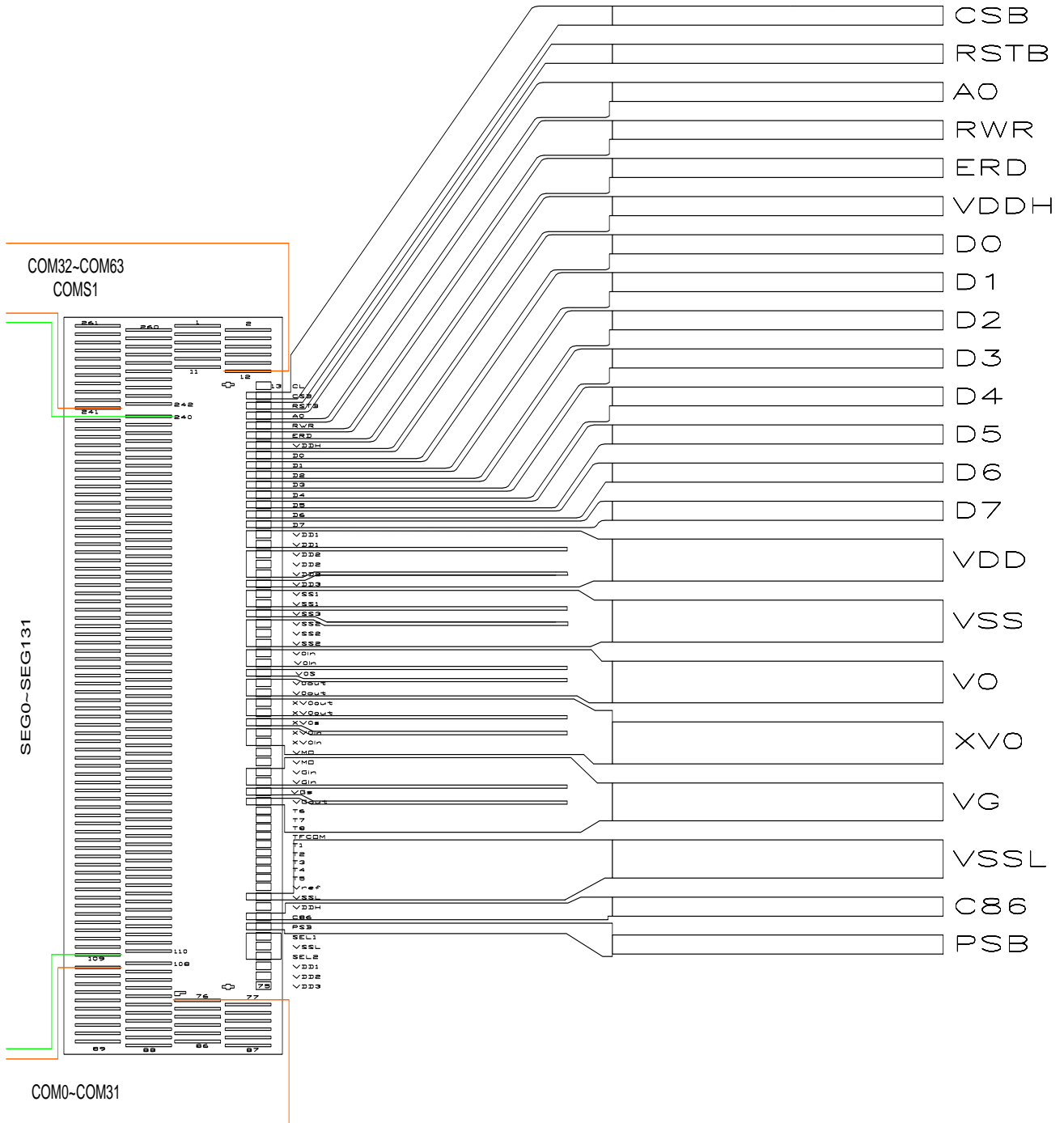

Note:

- Recommend ITO resistance refer to Page11.



## REVERSION HISTORY

Version	Date	Description
1.0	2008/02/15	<ul style="list-style-type: none"> <li>● Update DC Characteristics.</li> <li>● Update Timing Characteristic.</li> </ul>
1.0a	2008/02/19	<ul style="list-style-type: none"> <li>● Update Chip Thickness.</li> <li>● Add Pass Number.</li> </ul>
1.1	2008/03/21	<ul style="list-style-type: none"> <li>● Modify outline description.</li> <li>● Fix some arrow direction in Block Diagram.</li> <li>● Add more information of operation flow.</li> <li>● Change DC Characteristics of VDD1 range: 1.7V ~ 3.3V.</li> <li>● Add ITO layout note.</li> </ul>
1.2	2008/06/26	<ul style="list-style-type: none"> <li>● Modify Voltage Booster Level.</li> <li>● Add Application Voltage Guide.</li> <li>● Modify storage temperature.</li> <li>● Modify Current Consumption of DC Characteristics.</li> <li>● Modify temperature range of Timing Characteristic.</li> </ul>
1.3	2008/07/11	<ul style="list-style-type: none"> <li>● Add ITO Layout Guide.</li> </ul>
1.3a	2008/07/22	<ul style="list-style-type: none"> <li>● Modify Power ON Sequence.</li> <li>● Add Cap. C3 in Application Note.</li> </ul>
1.4	2008/10/16	<ul style="list-style-type: none"> <li>● Modify ITO Layout Guide.</li> <li>● Modify Application note.</li> </ul>
1.4a	2008/11/06	<ul style="list-style-type: none"> <li>● Modify ITO Layout Guide.</li> </ul>
1.4b	2009/02/04	<ul style="list-style-type: none"> <li>● Add description of output pin name in different duty.</li> </ul>
1.5	2010/08/06	<ul style="list-style-type: none"> <li>● Modify Bump Height, Bump Size and Bump Space.</li> </ul>
1.6	2011/11/12	<ul style="list-style-type: none"> <li>● Modify definition of operational power.</li> <li>● Modify incorrect type of VDDH and VSSL.</li> <li>● Modify limitation of VM power.</li> </ul>
1.7	2012/06/15	<ul style="list-style-type: none"> <li>● Modify bump height.</li> </ul>
1.7a	2013/08/07	<ul style="list-style-type: none"> <li>● Modify ABSOLUTE MAXIMUM RATINGS.</li> <li>● Change DC Characteristics of VDD1 range.</li> <li>● Change DC Characteristics of VDD2 and VDD3 range.</li> <li>● Modify Features.</li> <li>● Modify PIN DESCRIPTION, ITO Layout Reference and Application Circuits.</li> </ul>
1.8	2016/02/16	<ul style="list-style-type: none"> <li>● Modify Test Command Description.</li> <li>● Modify Refresh Process.</li> </ul>
1.9	2016/07/14	<ul style="list-style-type: none"> <li>● Modify Column Address Instructions</li> </ul>