

■ Features

- **5 x 8 dot matrix possible**
 - **Low power operation support:**
-- 2.7 to 5.5V
 - **Range of LCD driver power**
-- 3.0 to 7.0V
 - **4-bit, 8-bit, serial MPU or 400kbits/s fast I²C-bus interface are available**
 - **80 x 8-bit display RAM (80 characters max.)**
 - **10,240-bit character generator ROM for a total of 256 character fonts(max)**
 - **64 x 8-bit character generator RAM(max)**
 - **16-common x 80-segment and 1-common x 80-segment ICON liquid crystal display driver**
 - **16 x 5 –bit ICON RAM(max)**
 - **Wide range of instruction functions:**
- **Automatic reset circuit that initializes the controller/driver after power on and external reset pin**
 - **Internal oscillator(Frequency=540KHz) and external clock**
 - **Built-in voltage booster and follower circuit (low power consumption)**
 - **Com/Seg direction selectable**
 - **Multi-selectable for CGRAM/CGROM size**
 - **Instruction compatible to ST7066U and KS0066U and HD44780**
 - **Available in COG type**

■ Description

The ST7032 dot-matrix liquid crystal display controller can display alphanumeric, Japanese kana characters, and symbols. It can be configured to drive a dot-matrix liquid crystal display under the control of a 4 / 8-bit with 6800-series or 8080-series, 3/4-line serial interface microprocessor. Since all the functions such as display RAM, character generator ROM/RAM and liquid crystal driver, required for driving a dot-matrix liquid crystal display are internally provided on one chip, a minimal system can be used with this controller/driver.



The ST7032 character generator ROM size is 256 5x8dot bits which can be used to generate 256 different character fonts (5x8dot).

The ST7032 is suitable for low voltage supply (2.7V to 5.5V) and is perfectly suitable for any portable product which is

driven by the battery and requires low power consumption. The ST7032 LCD driver consists of 17 common signal drivers and 80 segment signal drivers. The maximum display RAM size can be either 80 characters in 1-line display or 40 characters in 2-line display. A single ST7032 can display up to one 16-character line or two 16-character lines.

The ST7032 dot-matrix LCD driver does not need extra cascaded drivers.

The ST7032 is designed for consumer applications; this product is not designed for use in cars, motorcycles, marine equipment, aircraft equipment, military equipment and other applications in extreme environment.

ST7032	6800-4bit / 8bit, 4-Line interface (without IIC interface)	
ST7032i	IIC interface	

■ Product Number

Please specify correct product number for application, and refer to the appendix for the character generation ROM code information.

Product Number	Character Generator ROM Size	OPR1	OPR2	Support Character
ST7032-0D-GB ST7032-0D-GC	256	1	1	Standard Code (English/ Japan/ European)
ST7032i-0D-GB ST7032i-0D-GC	256	1	1	Standard Code (English/ Japan/ European)
ST7032-0F-GB ST7032-0F-GC	240	0	0	Standard Code (English/ Japan/ European)
ST7032i-0F-GB ST7032i-0F-GC	240	0	0	Standard Code (English/ Japan/ European)

ST7032 Serial Specification Revision History		
Version	Date	Description
1.0	2003/3/24	<ol style="list-style-type: none"> 1. Change "Version 0.1y-Preliminary" to "Version 1.0" 2. Modify Bias resistor value 3. Modify OSC frequency table 4. Adding Serial interface flow chart & example code 5. Adding "E" connection state for serial interface
1.1	2003/8/27	Include ST7032i
1.2	2005/10/17	<ol style="list-style-type: none"> 1. To modify Operating Temperature Range Ta=-30°C to 85°C 2. To modify Storage Temperature Range Ta=-65°C to 150°C 3. To modify the vlcd voltage Range 3.0v~7.0v 4. To modify the limiting values -0.3v~+6.0v 5. To add Chip Thickness: 480 um
1.2a	2006/05/23	Modify description mistake (Page 1)
1.3	2007/11/09	<ol style="list-style-type: none"> 1. Add appendix section for Character Generation ROM. 2. Move ROM table to appendix.
1.4	2008/08/18	Update I/O PAD Circuit
1.5	2013/04/29	Modify Bump Height
1.6	2015/07/30	Modify Product Number
1.6a	2015/11/10	Modify Product Number Format
1.7	2018/03/06	Add ROM code "0F"
1.8	2023/05/22	<ol style="list-style-type: none"> 1. Add Notes for Absolute Maximum Ratings 2. Add Product Application Category Description 3. Add I2C Acknowledge Description
1.9	2023/06/12	<ol style="list-style-type: none"> 1. Add New Product Number 2. Add Select Display Mode in CGRAM or CGROM of 0F ROM Code

■ Pad Dimensions

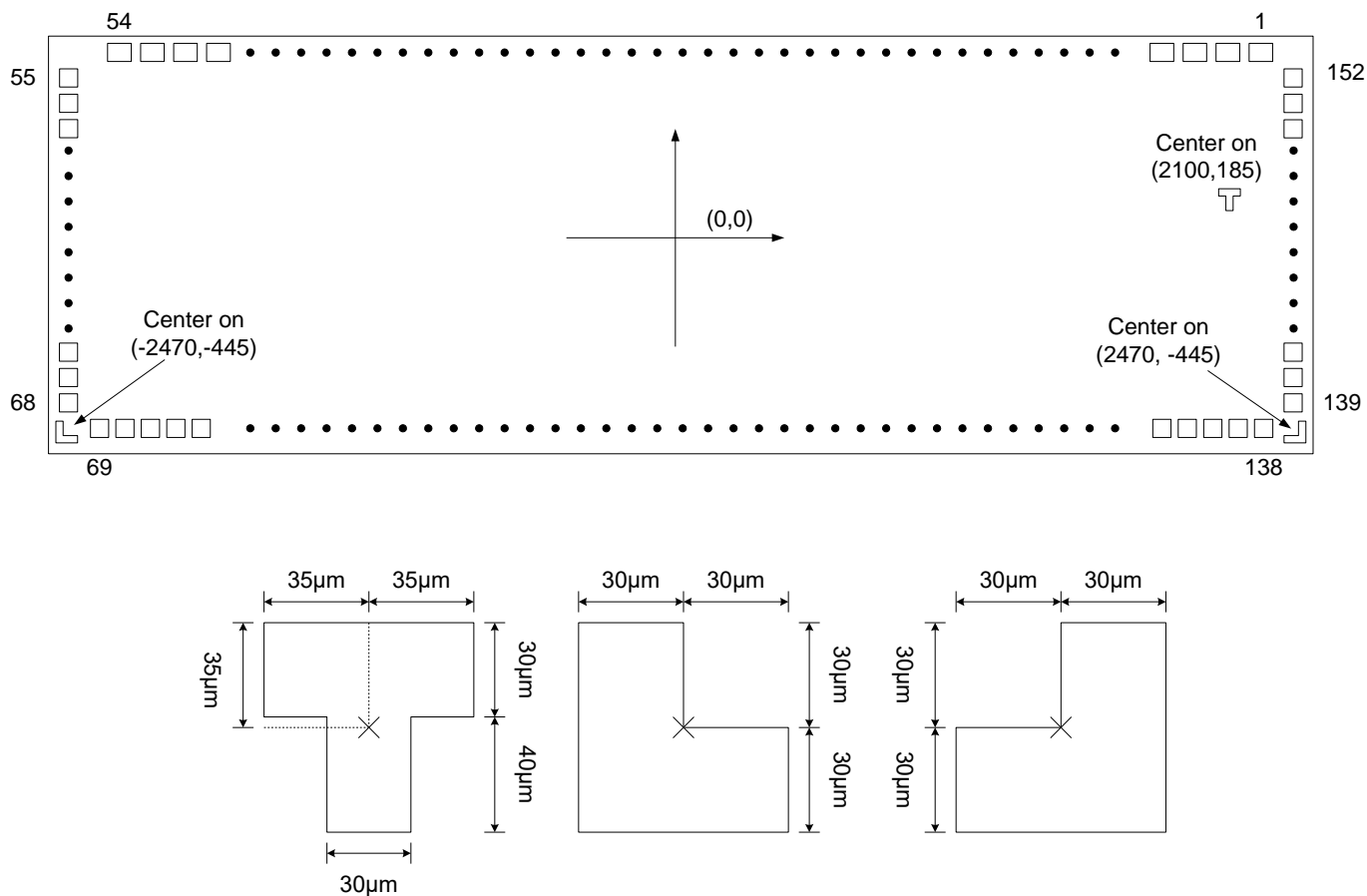

- **Chip Size: 5130.0 x 1080.0 μm**
- **Chip Thickness: 480 μm**
- **Bump Pitch : 62 μm(min)**
- **Bump Height : 12 μm(Typ)**
- **Bump Size :**
 - **Pad No.1~54 : 54 x 97 μm**
 - **Pad No.55~152 : 40 x 97 μm**

■ Pad Location Coordinates

Pad No.	Function	X	Y
1	XRESET	2165.5	420.5
2	OSC1	2089.5	420.5
3	OSC2	2013.5	420.5
4	RS	1937.5	420.5
5	CSB	1861.5	420.5
6	RW	1785.5	420.5
7	E	1709.5	420.5
8	DB0	1633.5	420.5
9	DB1	1557.5	420.5
10	DB2	1481.5	420.5
11	DB3	1405.5	420.5
12	DB4	1329.5	420.5
13	DB5	1253.5	420.5
14	DB6	1177.5	420.5
15	DB7	1101.5	420.5
16	VSS	1025.5	420.5
17	VSS	949.5	420.5
18	VSS	873.5	420.5
19	OPF1	797.5	420.5
20	OPF2	721.5	420.5
21	OPR1	645.5	420.5
22	OPR2	569.5	420.5
23	SHLC	493.5	420.5
24	SHLS	417.5	420.5
25	VDD	341.5	420.5
26	VDD	265.5	420.5
27	VDD	189.5	420.5
28	VIN	113.5	420.5
29	VIN	37.5	420.5
30	TEST1	-38.5	420.5
31	TEST2	-114.5	420.5
32	VSS	-190.5	420.5
33	NC	-266.5	420.5
34	VOUT	-342.5	420.5
35	VOUT	-418.5	420.5
36	PSB	-494.5	420.5
37	VSS	-570.5	420.5
38	PSI2B	-646.5	420.5
39	CAP1P	-722.5	420.5
40	CAP1P	-798.5	420.5

Pad No.	Function	X	Y
41	EXT	-874.5	420.5
42	VSS	-950.5	420.5
43	CLS	-1026.5	420.5
44	CAP1N	-1102.5	420.5
45	CAP1N	-1178.5	420.5
46	VOUT	-1254.5	420.5
47	VOUT	-1330.5	420.5
48	V0	-1406.5	420.5
49	V0	-1482.5	420.5
50	V1	-1558.5	420.5
51	V2	-1634.5	420.5
52	V3	-1710.5	420.5
53	V4	-1786.5	420.5
54	NC	-1862.5	420.5
55	COM[8]	-2445.5	423
56	COM[7]	-2445.5	361
57	COM[6]	-2445.5	299
58	COM[5]	-2445.5	237
59	COM[4]	-2445.5	175
60	COM[3]	-2445.5	113
61	COM[2]	-2445.5	51
62	COM[1]	-2445.5	-11
63	COM1	-2445.5	-73
64	SEG[1]	-2445.5	-135
65	SEG[2]	-2445.5	-197
66	SEG[3]	-2445.5	-259
67	SEG[4]	-2445.5	-321
68	SEG[5]	-2445.5	-383
69	SEG[6]	-2130.5	-420.5
70	SEG[7]	-2068.5	-420.5
71	SEG[8]	-2006.5	-420.5
72	SEG[9]	-1944.5	-420.5
73	SEG[10]	-1882.5	-420.5
74	SEG[11]	-1820.5	-420.5
75	SEG[12]	-1758.5	-420.5
76	SEG[13]	-1696.5	-420.5
77	SEG[14]	-1634.5	-420.5
78	SEG[15]	-1572.5	-420.5
79	SEG[16]	-1510.5	-420.5
80	SEG[17]	-1448.5	-420.5

Pad No.	Function	X	Y
81	SEG[18]	-1386.5	-420.5
82	SEG[19]	-1324.5	-420.5
83	SEG[20]	-1262.5	-420.5
84	SEG[21]	-1200.5	-420.5
85	SEG[22]	-1138.5	-420.5
86	SEG[23]	-1076.5	-420.5
87	SEG[24]	-1014.5	-420.5
88	SEG[25]	-952.5	-420.5
89	SEG[26]	-890.5	-420.5
90	SEG[27]	-828.5	-420.5
91	SEG[28]	-766.5	-420.5
92	SEG[29]	-704.5	-420.5
93	SEG[30]	-642.5	-420.5
94	SEG[31]	-580.5	-420.5
95	SEG[32]	-518.5	-420.5
96	SEG[33]	-456.5	-420.5
97	SEG[34]	-394.5	-420.5
98	SEG[35]	-332.5	-420.5
99	SEG[36]	-270.5	-420.5
100	SEG[37]	-208.5	-420.5
101	SEG[38]	-146.5	-420.5
102	SEG[39]	-84.5	-420.5
103	SEG[40]	-22.5	-420.5
104	SEG[41]	39.5	-420.5
105	SEG[42]	101.5	-420.5
106	SEG[43]	163.5	-420.5
107	SEG[44]	225.5	-420.5
108	SEG[45]	287.5	-420.5
109	SEG[46]	349.5	-420.5
110	SEG[47]	411.5	-420.5
111	SEG[48]	473.5	-420.5
112	SEG[49]	535.5	-420.5
113	SEG[50]	597.5	-420.5
114	SEG[51]	659.5	-420.5
115	SEG[52]	721.5	-420.5
116	SEG[53]	783.5	-420.5
117	SEG[54]	845.5	-420.5
118	SEG[55]	907.5	-420.5
119	SEG[56]	969.5	-420.5
120	SEG[57]	1031.5	-420.5

Pad No.	Function	X	Y
121	SEG[58]	1093.5	-420.5
122	SEG[59]	1155.5	-420.5
123	SEG[60]	1217.5	-420.5
124	SEG[61]	1279.5	-420.5
125	SEG[62]	1341.5	-420.5
126	SEG[63]	1403.5	-420.5
127	SEG[64]	1465.5	-420.5
128	SEG[65]	1527.5	-420.5
129	SEG[66]	1589.5	-420.5
130	SEG[67]	1651.5	-420.5
131	SEG[68]	1713.5	-420.5
132	SEG[69]	1775.5	-420.5
133	SEG[70]	1837.5	-420.5
134	SEG[71]	1899.5	-420.5
135	SEG[72]	1961.5	-420.5
136	SEG[73]	2023.5	-420.5
137	SEG[74]	2085.5	-420.5
138	SEG[75]	2147.5	-420.5
139	SEG[76]	2445.5	-383
140	SEG[77]	2445.5	-321
141	SEG[78]	2445.5	-259
142	SEG[79]	2445.5	-197
143	SEG[80]	2445.5	-135
144	COM[9]	2445.5	-73
145	COM[10]	2445.5	-11
146	COM[11]	2445.5	51
147	COM[12]	2445.5	113
148	COM[13]	2445.5	175
149	COM[14]	2445.5	237
150	COM[15]	2445.5	299
151	COM[16]	2445.5	361
152	COMI2	2445.5	423

■ Block Diagram

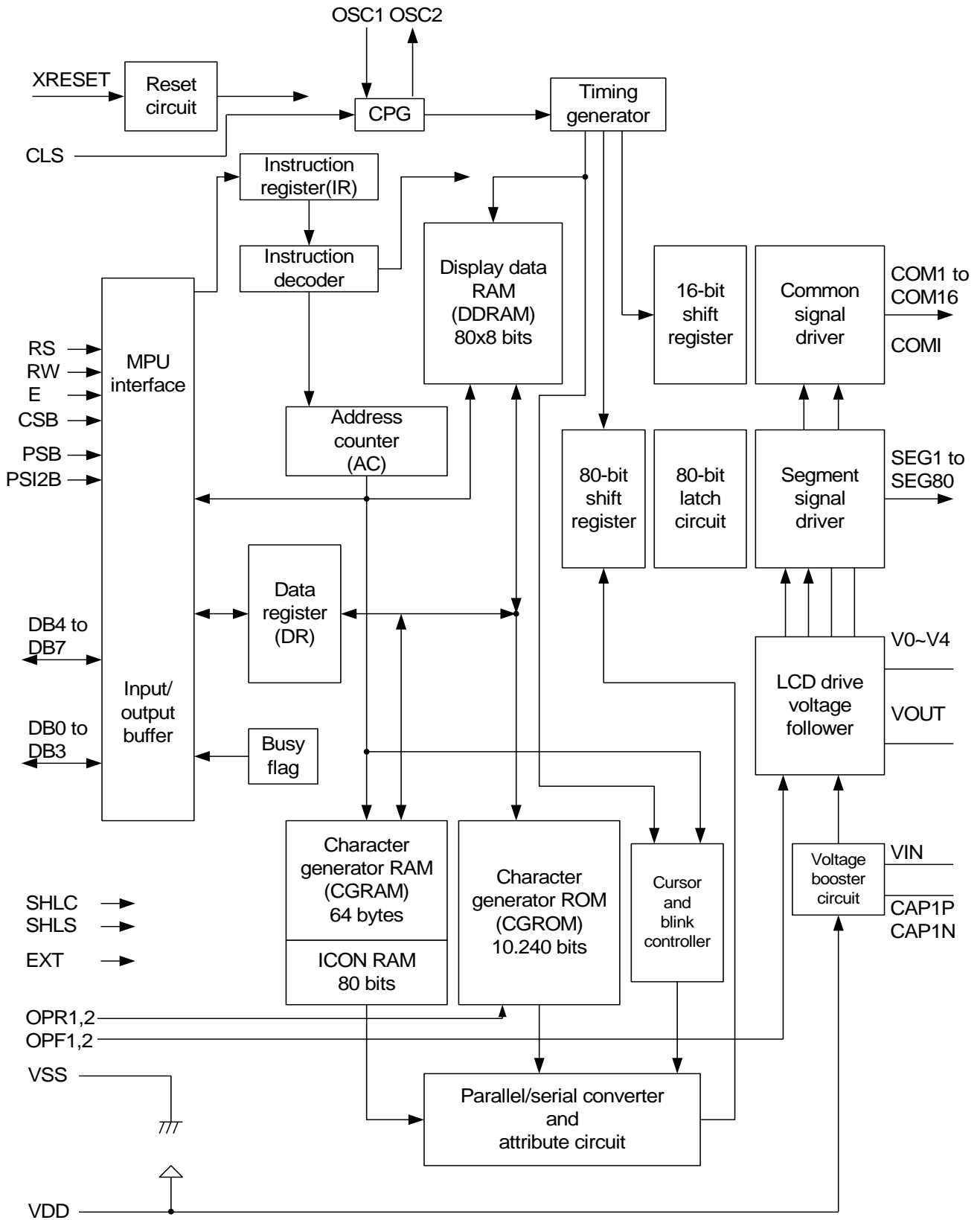

■ Pin Function

Name	Number	I/O	Interfaced with	Function																				
XRESET	1	I	MPU	External reset pin. Only if the power on reset used, the XRESET pin must be fixed to VDD. Low active.																				
RS	1	I	MPU	Select registers. 0: Instruction register (for write) Busy flag & address counter (for read) 1: Data register (for write and read)																				
R/W	1	I	MPU	Select read or write (In parallel mode). 0: Write 1: Read																				
E	1	I	MPU	Starts data read/write. ("E" must connect to "VDD" when serial interface is selected.)																				
CSB	1	I	MPU	Chip select in parallel mode and serial interface (Low active). When the CSB in falling edge state (in serial interface), the shift register and the clock counter are reset.																				
DB4 to DB7	4	I/O	MPU	Four high order bi-directional data bus pins. Used for data transfer and receive between the MPU and the ST7032. DB7 can be used as a busy flag. In serial interface mode DB7 is SI (input data), DB6 is SCL (serial clock). In I ² C interface DB7 (SDA) is input data and DB6 (SCL) is clock input. SDA and SCL must connect to I ² C bus (I ² C bus is to connect a resistor between SDA/SCL and the power of I ² C bus).																				
DB0 to DB3	4	I/O	MPU	Four low order bi-directional data bus pins. Used for data transfer and receive between the MPU and the ST7032. These pins are not used during 4-bit operation.																				
Ext	1	I	ITO option	Extension instruction select: 0:enable extension instruction(add contrast/ICON/double height font/ extension instruction) 1:disable extension instruction(compatible to ST7066U, but without 5x11 dot font)																				
PSB	1	I	MPU	Interface selection 0:serial mode ("E" must connect to "VDD" when serial mode is selected.) 1:parallel mode(4/8 bit) In I ² C interface PSB must connect to VDD																				
PSI2B	1	I	ITO option	<table border="1"> <thead> <tr> <th>PSB</th> <th>PSI2B</th> <th>Interface</th> </tr> </thead> <tbody> <tr> <td>0</td> <td>0</td> <td>No use</td> </tr> <tr> <td>0</td> <td>1</td> <td>SI4</td> </tr> <tr> <td>1</td> <td>0</td> <td>SI2 (I²C)</td> </tr> <tr> <td>1</td> <td>1</td> <td>Parallel 68</td> </tr> </tbody> </table>	PSB	PSI2B	Interface	0	0	No use	0	1	SI4	1	0	SI2 (I ² C)	1	1	Parallel 68					
PSB	PSI2B	Interface																						
0	0	No use																						
0	1	SI4																						
1	0	SI2 (I ² C)																						
1	1	Parallel 68																						
OPR1, OPR2	2	I	ITO option	Character generator select: <table border="1"> <thead> <tr> <th>OPR1</th> <th>OPR2</th> <th>CGROM</th> <th>CGRAM</th> </tr> </thead> <tbody> <tr> <td>0</td> <td>0</td> <td>240</td> <td>8</td> </tr> <tr> <td>0</td> <td>1</td> <td>250</td> <td>6</td> </tr> <tr> <td>1</td> <td>0</td> <td>248</td> <td>8</td> </tr> <tr> <td>1</td> <td>1</td> <td>256</td> <td>0</td> </tr> </tbody> </table>	OPR1	OPR2	CGROM	CGRAM	0	0	240	8	0	1	250	6	1	0	248	8	1	1	256	0
OPR1	OPR2	CGROM	CGRAM																					
0	0	240	8																					
0	1	250	6																					
1	0	248	8																					
1	1	256	0																					

Name	Number	I/O	Interfaced with	Function		
SHLC	1	I	ITO option	Common signals direction select: 0:Com1~16←Row address 15~0(Invert) 1:Com1~16←Row address 0~15(Normal)		
SHLS	1	I	ITO option	Segment signals direction select: 0:Seg1~80←Column address 79~0(Invert) 1:Seg1~80←Column address 0~79(Normal)		
COM1 to COM16	16	O	LCD	Common signals that are not used are changed to non-selection waveform. COM9 to COM16 are non-selection waveforms at 1/8 or 1/9 duty factor		
COMI	2	O	LCD	ICON common signals		
SEG1 to SEG80	80	O	LCD	Segment signals		
OPF1 OPF2	2	I	ITO option	The built-in voltage follower circuit selection		
				OPF1	OPF2	Bias select
				0	0	Built-in voltage follower(only use at EXT=0)
				0	1	Built-in bias resistor(3.3KΩ) ±30%
1	0	Built-in bias resistor(9.6KΩ) ±30%				
1	1	External bias resistor select				
CAP1P	1	-	Power supply	For voltage booster circuit(VDD-VSS) External capacitor about 0.1u~4.7uf		
CAP1N	1	-	Power supply			
VIN	1	-	Power supply	Input the voltage to booster		
VOUT	1	-	Power supply	DC/DC voltage converter. Connect a capacitor between this terminal and VIN when the built-in booster is used.		
V0 to V4	5	-	Power supply	Power supply for LCD drive V0-Vss = 7V (Max) Built-in/external Voltage follower circuit		
VDD VSS	2	-	Power supply	VDD : 2.7V to 5.5V, VSS: 0V		
CLS		I	ITO option	Internal/External oscillation select 0:external clock 1:internal oscillation		
OSC1 OSC2	2	I/O	Oscillation	When the pin input is an external clock, it must be input to OSC1.		
TEST1,2	2	I/O	Test pin	TEST1,2 must connect to VDD.		

■ EXT option pin difference table

	ST7066U normal mode (EXT=1)	Extension mode (EXT=0)
Booster	Always OFF	ON/OFF control by instruction
Bias (V0~V4)	Can't use the follower circuit Only use external resistor or internal resistor(1/5 bias)	Follower or internal/external resistor selectable
Contrast adjust	Control by external VR	1. Control by instruction with follower 2. Control by external VR with internal/external resistor
ICON RAM	Can't be use	RAM size has 80 bit width (S1~S80).
Instruction	Control normal instruction similar to ST7066U.	Control extension instruction for low power consumption.
Double height font	Only 5x8 font	Can set 5x8 or 5x16 font
OSC frequency adjust	Only adjust by external clock.	Can set OSC frequency by instruction set.

■ Function Description

● System Interface

This chip has all four kinds of interface type with MPU: 4-bit bus, 8-bit bus, serial and fast I²C interface. 4-bit bus or 8-bit bus is selected by DL bit in the instruction register.

During read or write operation, two 8-bit registers are used. One is data register (DR); the other is instruction register (IR).

The data register (DR) is used as temporary data storage place for being written into or read from DDRAM/CGRAM/ICON RAM, target RAM is selected by RAM address setting instruction. Each internal operation, reading from or writing into RAM, is done automatically. So to speak, after MPU reads DR data, the data in the next DDRAM/CGRAM/ICON RAM address is transferred into DR automatically. Also after MPU writes data to DR, the data in DR is transferred into DDRAM/CGRAM/ICON RAM automatically.

The Instruction register (IR) is used only to store instruction code transferred from MPU. MPU cannot use it to read instruction data.

Using RS input pin to select command or data in 4-bit/8-bit bus mode.

RS	R/W	Operation
L	L	Instruction Write operation (MPU writes Instruction code into IR)
L	H	Read Busy Flag (DB7) and address counter (DB0 ~ DB6)
H	L	Data Write operation (MPU writes data into DR)
H	H	Data Read operation (MPU reads data from DR)

Table 1. Various kinds of operations according to RS and R/W bits.

I²C interface

**It just only could write Data or Instruction to ST7032 by the IIC Interface.
It could not read Data or Instruction from ST7032 (except Acknowledge signal).**

SCL: serial clock input

SDA: serial data input

Slaver address could only set to 0111110, no other slaver address could be set

The I²C interface send RAM data and executes the commands sent via the I²C Interface. It could send data bit to the RAM. The I²C Interface is two-line communication between different ICs or modules. The two lines are a Serial Data line (SDA) and a Serial Clock line (SCL). Both lines must be connected to a positive supply via a pull-up resistor. Data transfer may be initiated only when the bus is not busy.

BIT TRANSFER

One data bit is transferred during each clock pulse. The data on the SDA line must remain stable during the HIGH period of the clock pulse because changes in the data line at this time will be interpreted as a control signal. Bit transfer is illustrated in Fig.1.

START AND STOP CONDITIONS

Both data and clock lines remain HIGH when the bus is not busy. A HIGH-to-LOW transition of the data line, while the clock is HIGH is defined as the START condition (S). A LOW-to-HIGH transition of the data line while the clock is HIGH is defined as the STOP condition (P). The START and STOP conditions are illustrated in Fig.2.

SYSTEM CONFIGURATION

The system configuration is illustrated in Fig.3.

- Transmitter: the device, which sends the data to the bus
- Master: the device, which initiates a transfer, generates clock signals and terminates a transfer
- Slave: the device addressed by a master

- Multi-Master: more than one master can attempt to control the bus at the same time without corrupting the message
- Arbitration: procedure to ensure that, if more than one master simultaneously tries to control the bus, only one is allowed to do so and the message is not corrupted
- Synchronization: procedure to synchronize the clock signals of two or more devices.

ACKNOWLEDGE

Acknowledge is not Busy Flag in I2C interface.

Each byte of eight bits is followed by an acknowledge bit. The acknowledge bit is a HIGH signal put on the bus by the transmitter during which time the master generates an extra acknowledge related clock pulse. A slave receiver which is addressed must generate an acknowledge after the reception of each byte. A master receiver must also generate an acknowledge after the reception of each byte that has been clocked out of the slave transmitter. The master transmitter must release the SDA line floating within the acknowledge clock cycle for use by the slave receiver. The device that acknowledges must pull-down the SDA line during the acknowledge clock pulse, so that the SDA line is stable LOW during the HIGH period of the acknowledge related clock pulse (set-up and hold times must be taken into consideration). A master receiver must signal an end-of-data to the transmitter by not generating an acknowledge on the last byte that has been clocked out of the slave. In this event the transmitter must leave the data line HIGH to enable the master to generate a STOP condition. Acknowledgement on the I²C Interface is illustrated in Fig.4.

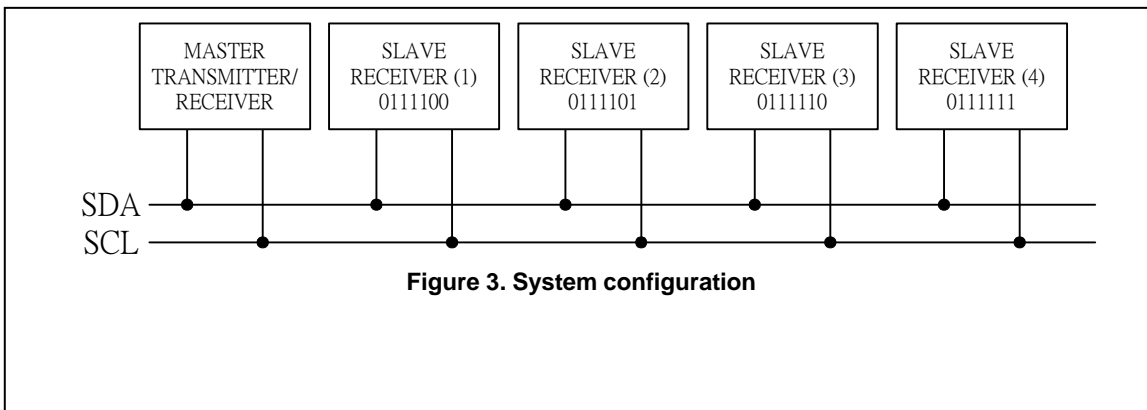
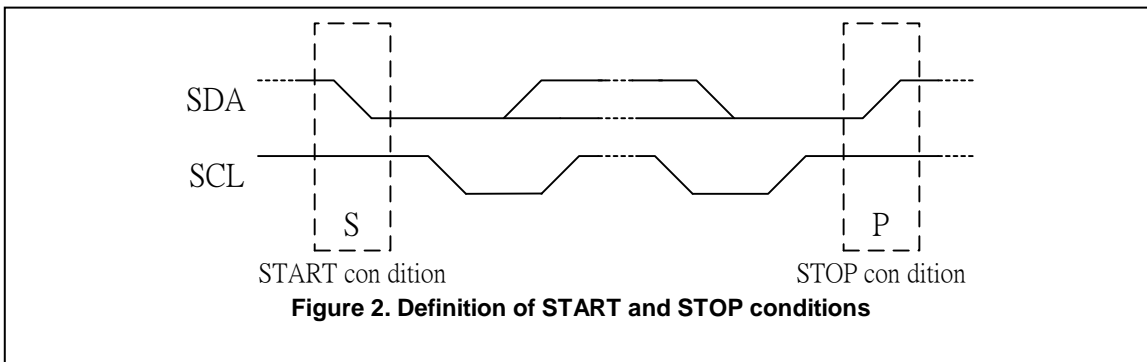
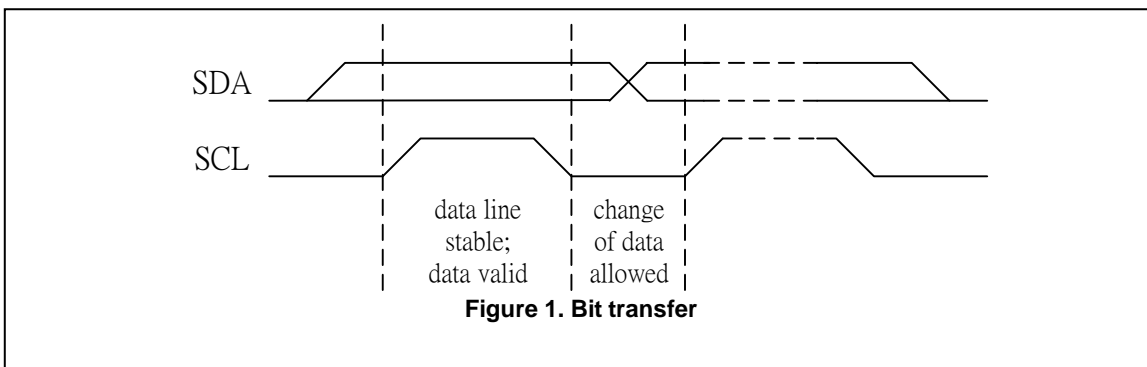

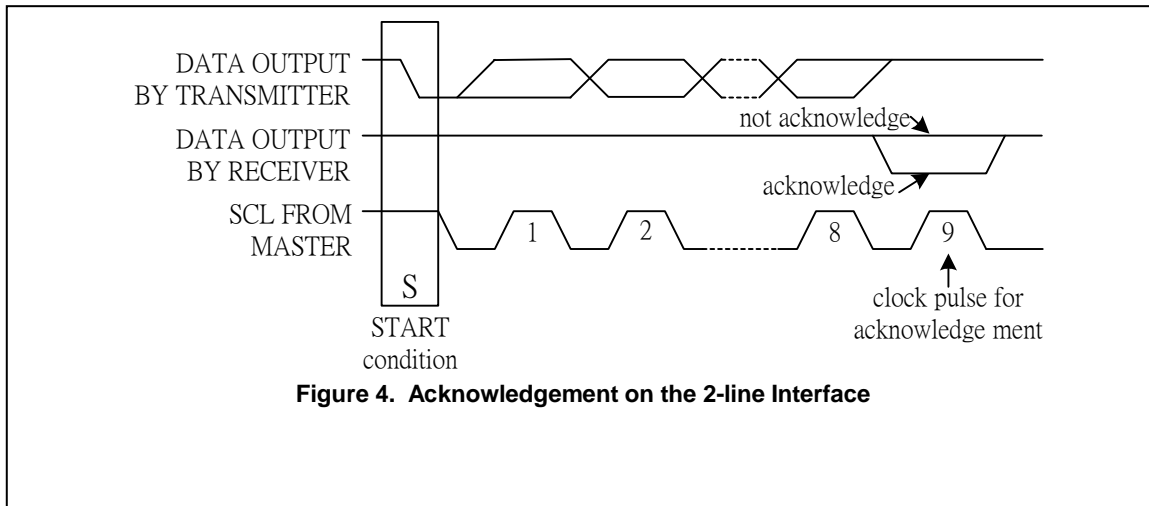

Figure 4. Acknowledgement on the 2-line Interface

I²C Interface protocol

The ST7032 supports command, data write addressed slaves on the bus.

Before any data is transmitted on the I²C Interface, the device, which should respond, is addressed first. Only one 7-bit slave addresses (0111110) is reserved for the ST7032. The R/W is assigned to 0 for Write only.

The I²C Interface protocol is illustrated in Fig.5.

The sequence is initiated with a START condition (S) from the I²C Interface master, which is followed by the slave address. All slaves with the corresponding address acknowledge in parallel, all the others will ignore the I²C Interface transfer. After acknowledgement, one or more command words follow which define the status of the addressed slaves.

A command word consists of a control byte, which defines Co and RS, plus a data byte.

The last control byte is tagged with a cleared most significant bit (i.e. the continuation bit Co). After a control byte with a cleared Co bit, only data bytes will follow. The state of the RS bit defines whether the data byte is interpreted as a command or as RAM data. All addressed slaves on the bus also acknowledge the control and data bytes. After the last control byte, depending on the RS bit setting; either a series of display data bytes or command data bytes may follow. If the RS bit is set to logic 1, these display bytes are stored in the display RAM at the address specified by the data pointer. The data pointer is automatically updated and the data is directed to the intended ST7032i device. If the RS bit of the last control byte is set to logic 0, these command bytes will be decoded and the setting of the device will be changed according to the received commands. Only the addressed slave makes the acknowledgement after each byte. At the end of the transmission the I²C INTERFACE-bus master issues a STOP condition (P).

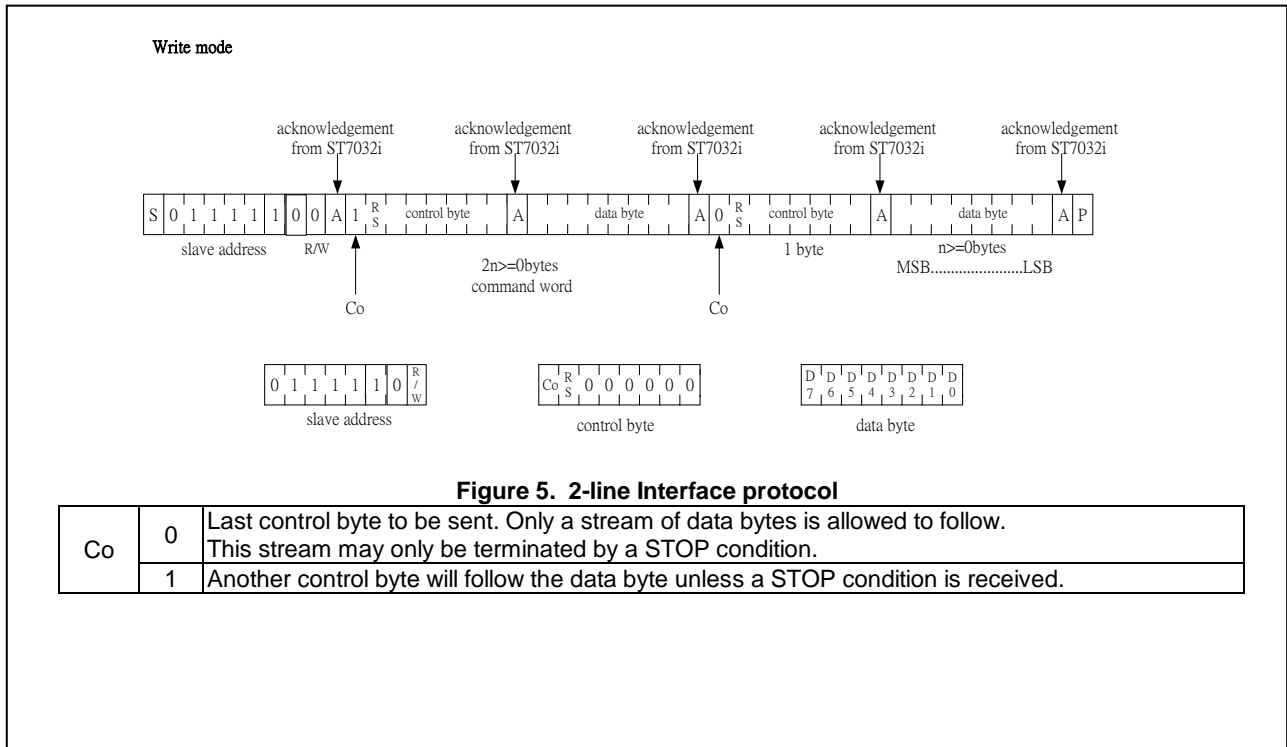

During write operation, two 8-bit registers are used. One is data register (DR), the other is instruction register (IR).

The data register (DR) is used as temporary data storage place for being written into DDRAM/CGRAM/ICON RAM, target RAM is selected by RAM address setting instruction. Each internal operation, writing into RAM, is done automatically. So to speak, after MPU writes data to DR, the data in DR is transferred into DDRAM/CGRAM/ICON RAM automatically.

The Instruction register (IR) is used only to store instruction code transferred from MPU. MPU cannot use it to read instruction data.

To select register, use RS input in I²C interface.

RS	R/W	Operation
L	L	Instruction Write operation (MPU writes Instruction code into IR)
H	L	Data Write operation (MPU writes data into DR)

Table 2. Various kinds of operations according to RS and R/W bits.

● **Busy Flag (BF)**

When BF = "High", it indicates that the internal operation is being processed. So during this time the next instruction cannot be accepted. BF can be read, when RS = Low and R/W = High (Read Instruction Operation), through DB7 port. Before executing the next instruction, be sure that BF is not High.

● **Address Counter (AC)**

Address Counter (AC) stores DDRAM/CGRAM/ICON RAM address, transferred from IR. After writing into (reading from) DDRAM/CGRAM/ICON RAM, AC is automatically increased (decreased) by 1. When RS = "Low" and R/W = "High", AC can be read through DB0 ~ DB6 ports.

● **Display Data RAM (DDRAM)**

Display data RAM (DDRAM) stores display data represented in 8-bit character codes. Its extended capacity is 80 x 8 bits, or 80 characters. The area in display data RAM (DDRAM) that is not used for display can be used as general data RAM. See Figure 7 for the relationships between DDRAM addresses and positions on the liquid crystal display.

The DDRAM address (A_{DD}) is set in the address counter (AC) as hexadecimal.

➤ **1-line display (N = 0) (Figure 8)**

When there are fewer than 80 display characters, the display begins at the head position. For example, if using only the ST7032, 16 characters are displayed. See Figure 8.

When the display shift operation is performed, the DDRAM address shifts. See Figure 9.

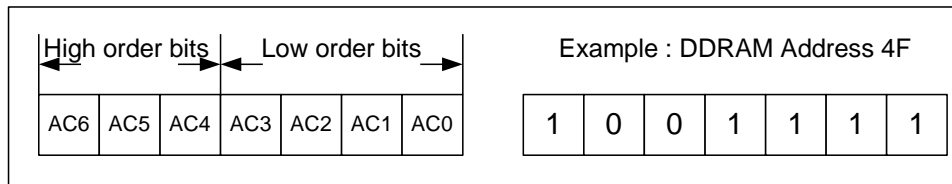

Figure 7. DDRAM Address

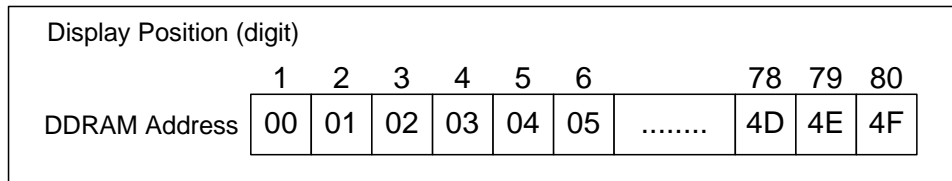

Figure 8. 1-Line Display

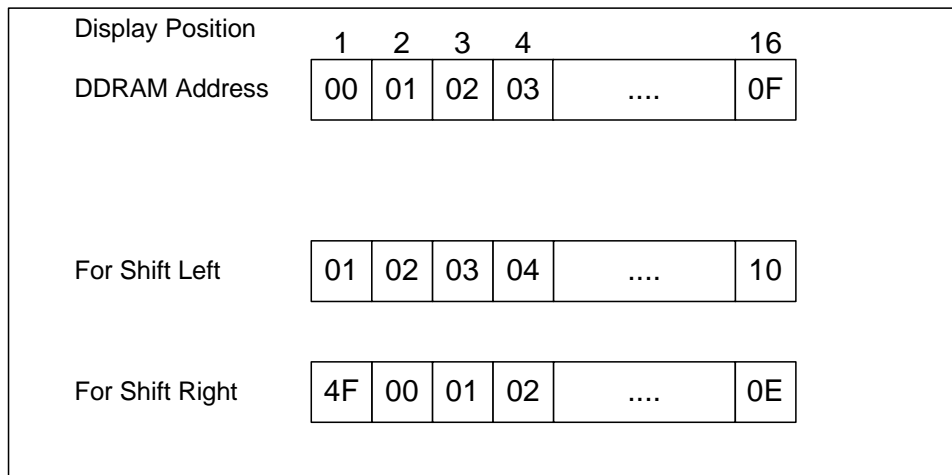

Figure 9. 1-Line by 16-Character Display Example

➤ **2-line display (N = 1) (Figure 10)**

Case 1: When the number of display characters is less than 40 2 lines, the two lines are displayed from the head. Note that the first line end address and the second line start address are not consecutive. See Figure 10.

Display Position	1	2	3	4	5	6		38	39	40
DDRAM Address (hexadecimal)	00	01	02	03	04	05	25	26	27
	40	41	42	43	44	45	65	66	67

Figure 10. 2-Line Display

Case 2: For a 16-character 2-line display See Figure 11.
 When display shift operation is performed, the DDRAM address shifts. See Figure 11.

Display Position	1	2	3	4	5	6	7	8	9	10	11	12	13	14	15	16
DDRAM Address	00	01	02	03	04	05	06	07	08	09	0A	0B	0C	0D	0E	0F
	40	41	42	43	44	45	46	47	48	49	4A	4B	4C	4D	4E	4F
For Shift Left	01	02	03	04	05	06	07	08	09	0A	0B	0C	0D	0E	0F	10
	41	42	43	44	45	46	47	48	49	4A	4B	4C	4D	4E	4F	50
For Shift Right	27	00	01	02	03	04	05	06	07	08	09	0A	0B	0C	0D	0E
	67	40	41	42	43	44	45	46	47	48	49	4A	4B	4C	4D	4E

Figure 11. 2-Line by 16-Character Display Example

- **Character Generator ROM (CGROM)**

The character generator ROM generates 5 x 8 dot character patterns from 8-bit character codes. It can generate 240/250/248/256 5 x 8 dot character patterns (select by OPR1/2 ITO pin). User-defined character patterns are also available by mask-programmed ROM.

- **Character Generator RAM (CGRAM)**

In the character generator RAM, the user can rewrite character patterns by program. For 5 x 8 dots, eight character patterns can be written.

Write into DDRAM the character codes at the addresses shown as the left column of code table (refer to appendix) to show the character patterns stored in CGRAM.

See Table 4 for the relationship between CGRAM addresses and data and display patterns. Areas that are not used for display can be used as general data RAM.

- **ICON RAM**

In the ICON RAM, the user can rewrite icon pattern by program.

There are totally 80 dots for icon can be written.

See Table 5 for the relationship between ICON RAM address and data and the display patterns.

- **Timing Generation Circuit**

The timing generation circuit generates timing signals for the operation of internal circuits such as DDRAM, CGROM and CGRAM. RAM read timing for display and internal operation timing by MPU access are generated separately to avoid interfering with each other. Therefore, when writing data to DDRAM, for example, there will be no undesirable interference, such as flickering, in areas other than the display area. (In I²C interface the reading function is invalid.)

- **LCD Driver Circuit**

LCD Driver circuit has 17 common and 80 segment signals for LCD driving. Data from CGRAM/CGROM/ICON is transferred to 80 bit segment latch serially, and then it is stored to 80 bit shift latch. When each common is selected by 17 bit common register, segment data also output through segment driver from 80 bit segment latch.

- **Cursor/Blink Control Circuit**

It can generate the cursor or blink in the cursor/blink control circuit. The cursor or the blink appears in the digit at the display data RAM address set in the address counter.

Character Code (DDRAM Data)								CGRAM Address						Character Patterns (CGRAM Data)							
b7	b6	b5	b4	b3	b2	b1	b0	b5	b4	b3	b2	b1	b0	b7	b6	b5	b4	b3	b2	b1	b0
0	0	0	0	-	0	0	0	0	0	0	0	0	0	-	-	-	1	1	1	1	1
					0	0	0				0	0	0				0	0	0		
					0	0	0				0	0	0				0	0	0		
					0	0	0				0	0	0				0	0	0		
					0	0	0				0	0	0				0	0	0		
					0	0	0				0	0	0				0	0	0		
					0	0	0				0	0	0				0	0	0		
					0	0	0				0	0	0				0	0	0		
0	0	0	0	-	0	0	1	0	0	1	0	0	0	-	-	-	1	1	1	1	0
					0	0	1				0	0	1				0	0	1		
					0	0	1				0	1	0				0	1	0	1	
					0	0	1				0	1	1				0	1	1	0	
					0	0	1				1	0	0				0	0	0	0	
					0	0	1				1	0	1				0	1	0	0	
					0	0	1				1	1	0				0	0	0	1	
					0	0	1				1	1	1				0	0	0	0	

Table 4. Relationship between CGRAM Addresses, Character Codes (DDRAM) and Character patterns (CGRAM Data)

Notes:

1. Character code bits 0 to 2 correspond to CGRAM address bits 3 to 5 (3 bits: 8 types).
2. CGRAM address bits 0 to 2 designate the character pattern line position. The 8th line is the cursor position and its display is formed by a logical OR with the cursor. Maintain the 8th line data, corresponding to the cursor display position, at 0 as the cursor display. If the 8th line data is 1, 1 bit will light up the 8th line regardless of the cursor presence.
3. Character pattern row positions correspond to CGRAM data bits 0 to 4 (bit 4 being at the left).
4. As shown Table 4, CGRAM character patterns are selected when character code bits 4 to 7 are all 0. However, since character code bit 3 has no effect, the R display example above can be selected by either character code 00H or 08H.
5. "1" for CGRAM data corresponds to display selection and "0" to non-selection, "-" Indicates no effect.
6. Different OPR1/2 ITO option can select different CGRAM size.

When SHLS=1, ICON RAM map refer below table

ICON address	ICON RAM bits							
	D7	D6	D5	D4	D3	D2	D1	D0
00H	-	-	-	S1	S2	S3	S4	S5
01H	-	-	-	S6	S7	S8	S9	S10
02H	-	-	-	S11	S12	S13	S14	S15
03H	-	-	-	S16	S17	S18	S19	S20
04H	-	-	-	S21	S22	S23	S24	S25
05H	-	-	-	S26	S27	S28	S29	S30
06H	-	-	-	S31	S32	S33	S34	S35
07H	-	-	-	S36	S37	S38	S39	S40
08H	-	-	-	S41	S42	S43	S44	S45
09H	-	-	-	S46	S47	S48	S49	S50
0AH	-	-	-	S51	S52	S53	S54	S55
0BH	-	-	-	S56	S57	S58	S59	S60
0CH	-	-	-	S61	S62	S63	S64	S65
0DH	-	-	-	S66	S67	S68	S69	S70
0EH	-	-	-	S71	S72	S73	S74	S75
0FH	-	-	-	S76	S77	S78	S79	S80

When SHLS=0, ICON RAM map refer below table

ICON address	ICON RAM bits							
	D7	D6	D5	D4	D3	D2	D1	D0
00H	-	-	-	S80	S79	S78	S77	S76
01H	-	-	-	S75	S74	S73	S72	S71
02H	-	-	-	S70	S69	S68	S67	S66
03H	-	-	-	S65	S64	S63	S62	S61
04H	-	-	-	S60	S59	S58	S57	S56
05H	-	-	-	S55	S54	S53	S52	S51
06H	-	-	-	S50	S49	S48	S47	S46
07H	-	-	-	S45	S44	S43	S42	S41
08H	-	-	-	S40	S39	S38	S37	S36
09H	-	-	-	S35	S34	S33	S32	S31
0AH	-	-	-	S30	S29	S28	S27	S26
0BH	-	-	-	S25	S24	S23	S22	S21
0CH	-	-	-	S20	S19	S18	S17	S16
0DH	-	-	-	S15	S14	S13	S12	S11
0EH	-	-	-	S10	S9	S8	S7	S6
0FH	-	-	-	S5	S4	S3	S2	S1

Table 5. ICON RAM map

When ICON RAM data is filled the corresponding position displayed is described as the following table.

■ Instructions

There are four categories of instructions that:

- Designate ST7032 functions, such as display format, data length, etc.
- Set internal RAM addresses
- Perform data transfer with internal RAM
- Others

➤ instruction table at “Normal mode”

(When “EXT” option pin connect to VDD, the instruction set follow below table)

Instruction	Instruction Code										Description	Instruction Execution Time			
	RS	R/W	DB7	DB6	DB5	DB4	DB3	DB2	DB1	DB0		OSC=380KHz	OSC=540kHz	OSC=700KHz	
Clear Display	0	0	0	0	0	0	0	0	0	1	Write "20H" to DDRAM. and set DDRAM address to "00H" from AC	1.08 ms	0.76 ms	0.59 ms	
Return Home	0	0	0	0	0	0	0	0	0	1	x	Set DDRAM address to "00H" from AC and return cursor to its original position if shifted. The contents of DDRAM are not changed.	1.08 ms	0.76 ms	0.59 ms
Entry Mode Set	0	0	0	0	0	0	0	0	1	I/D	S	Sets cursor move direction and specifies display shift. These operations are performed during data write and read.	26.3 us	18.5 us	14.3 us
Display ON/OFF	0	0	0	0	0	0	0	1	D	C	B	D=1:entire display on C=1:cursor on B=1:cursor position on	26.3 us	18.5 us	14.3 us
Cursor or Display Shift	0	0	0	0	0	0	1	S/C	R/L	x	x	S/C and R/L: Set cursor moving and display shift control bit, and the direction, without changing DDRAM data.	26.3 us	18.5 us	14.3 us
Function Set	0	0	0	0	0	1	DL	N	x	x	x	DL: interface data is 8/4 bits N: number of line is 2/1	26.3 us	18.5 us	14.3 us
Set CGRAM	0	0	0	1	AC5	AC4	AC3	AC2	AC1	AC0		Set CGRAM address in address counter	26.3 us	18.5 us	14.3 us
Set DDRAM address	0	0	1	AC6	AC5	AC4	AC3	AC2	AC1	AC0		Set DDRAM address in address counter	26.3 us	18.5 us	14.3 us
Read Busy flag and address	0	1	BF	AC6	AC5	AC4	AC3	AC2	AC1	AC0		Whether during internal operation or not can be known by reading BF. The contents of address counter can also be read.	0	0	0
Write data to RAM	1	0	D7	D6	D5	D4	D3	D2	D1	D0		Write data into internal RAM (DDRAM/CGRAM)	26.3 us	18.5 us	14.3 us
Read data from RAM	1	1	D7	D6	D5	D4	D3	D2	D1	D0		Read data from internal RAM (DDRAM/CGRAM)	26.3 us	18.5 us	14.3 us

Note:

Be sure the ST7032 is not in the busy state (BF = 0) before sending an instruction from the MPU to the ST7032. If an instruction is sent without checking the busy flag, the time between the first instruction and next instruction will take much longer than the instruction time itself. Refer to Instruction Table for the list of each instruction execution time.

➤ **instruction table at “Extension mode”**

(when “EXT” option pin connect to VSS, the instruction set follow below table)

Instruction	Instruction Code										Description	Instruction Execution Time			
	RS	R/W	DB7	DB6	DB5	DB4	DB3	DB2	DB1	DB0		OSC=380KHz	OSC=540kHz	OSC=700KHz	
Clear Display	0	0	0	0	0	0	0	0	0	1	Write "20H" to DDRAM. and set DDRAM address to "00H" from AC	1.08 ms	0.76 ms	0.59 ms	
Return Home	0	0	0	0	0	0	0	0	0	1	x	Set DDRAM address to "00H" from AC and return cursor to its original position if shifted. The contents of DDRAM are not changed.	1.08 ms	0.76 ms	0.59 ms
Entry Mode Set	0	0	0	0	0	0	0	0	1	I/D	S	Sets cursor move direction and specifies display shift. These operations are performed during data write and read.	26.3 us	18.5 us	14.3 us
Display ON/OFF	0	0	0	0	0	0	0	1	D	C	B	D=1:entire display on C=1:cursor on B=1:cursor position on	26.3 us	18.5 us	14.3 us
Function Set	0	0	0	0	1	DL	N	DH	*0	IS	DL: interface data is 8/4 bits N: number of line is 2/1 DH: double height font IS: instruction table select	26.3 us	18.5 us	14.3 us	
Set DDRAM address	0	0	1	AC6	AC5	AC4	AC3	AC2	AC1	AC0	Set DDRAM address in address counter	26.3 us	18.5 us	14.3 us	
Read Busy flag and address	0	1	BF	AC6	AC5	AC4	AC3	AC2	AC1	AC0	Whether during internal operation or not can be known by reading BF. The contents of address counter can also be read.	0	0	0	
Write data to RAM	1	0	D7	D6	D5	D4	D3	D2	D1	D0	Write data into internal RAM (DDRAM/CGRAM/ICONRAM)	26.3 us	18.5 us	14.3 us	
Read data from RAM	1	1	D7	D6	D5	D4	D3	D2	D1	D0	Read data from internal RAM (DDRAM/CGRAM/ICONRAM)	26.3 us	18.5 us	14.3 us	

Note * : this bit is for test command , and must always set to “0”

Instruction table 0(IS=0)

Cursor or Display Shift	0	0	0	0	0	1	S/C	R/L	x	x	S/C and R/L: Set cursor moving and display shift control bit, and the direction, without changing DDRAM data.	26.3 us	18.5 us	14.3 us
Set CGRAM	0	0	0	1	AC5	AC4	AC3	AC2	AC1	AC0	Set CGRAM address in address counter	26.3 us	18.5 us	14.3 us

Instruction table 1(IS=1)

Internal OSC frequency	0	0	0	0	0	1	BS	F2	F1	F0	BS=1:1/4 bias BS=0:1/5 bias F2~0: adjust internal OSC frequency for FR frequency.	26.3 us	18.5 us	14.3 us
Set ICON address	0	0	0	1	0	0	AC3	AC2	AC1	AC0	Set ICON address in address counter.	26.3 us	18.5 us	14.3 us
Power/ICON control/Contrast set	0	0	0	1	0	1	Ion	Bon	C5	C4	Ion: ICON display on/off Bon: set booster circuit on/off C5,C4: Contrast set for internal follower mode.	26.3 us	18.5 us	14.3 us
Follower control	0	0	0	1	1	0	Fon	Rab2	Rab1	Rab0	Fon: set follower circuit on/off Rab2~0: select follower amplified ratio.	26.3 us	18.5 us	14.3 us
Contrast set	0	0	0	1	1	1	C3	C2	C1	C0	Contrast set for internal follower mode.	26.3 us	18.5 us	14.3 us

■ Instruction Description

- **Clear Display**

RS	R/W	DB7	DB6	DB5	DB4	DB3	DB2	DB1	DB0
0	0	0	0	0	0	0	0	0	1

Clear all the display data by writing "20H" (space code) to all DDRAM address, and set DDRAM address to "00H" into AC (address counter). Return cursor to the original status, namely, bring the cursor to the left edge on first line of the display. Make entry mode increment (I/D = "1").

- **Return Home**

RS	R/W	DB7	DB6	DB5	DB4	DB3	DB2	DB1	DB0
0	0	0	0	0	0	0	0	1	X

Return Home is cursor return home instruction. Set DDRAM address to "00H" into the address counter. Return cursor to its original site and return display to its original status, if shifted. Contents of DDRAM do not change.

- **Entry Mode Set**

RS	R/W	DB7	DB6	DB5	DB4	DB3	DB2	DB1	DB0
0	0	0	0	0	0	0	1	I/D	S

Set the moving direction of cursor and display.

- **I/D : Increment / decrement of DDRAM address (cursor or blink)**
 When I/D = "High", cursor/blink moves to right and DDRAM address is increased by 1.
 When I/D = "Low", cursor/blink moves to left and DDRAM address is decreased by 1.
 * CGRAM operates the same as DDRAM, when read from or write to CGRAM.
- **S: Shift of entire display**
 When DDRAM read (CGRAM read/write) operation or S = "Low", shift of entire display is not performed. If S = "High" and DDRAM write operation, shift of entire display is performed according to I/D value (I/D = "1": shift left, I/D = "0" : shift right).

S	I/D	Description
H	H	Shift the display to the left
H	L	Shift the display to the right

● Display ON/OFF

RS	R/W	DB7	DB6	DB5	DB4	DB3	DB2	DB1	DB0
0	0	0	0	0	0	1	D	C	B

Control display/cursor/blink ON/OFF 1 bit register.

- **D : Display ON/OFF control bit**
When D = "High", entire display is turned on.
When D = "Low", display is turned off, but display data is remained in DDRAM.
- **C : Cursor ON/OFF control bit**
When C = "High", cursor is turned on.
When C = "Low", cursor is disappeared in current display, but I/D register remains its data.
- **B : Cursor Blink ON/OFF control bit**
When B = "High", cursor blink is on, that performs alternate between all the high data and display character at the cursor position.
When B = "Low", blink is off.

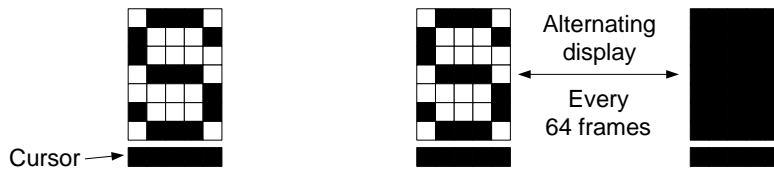

● Cursor or Display Shift

RS	R/W	DB7	DB6	DB5	DB4	DB3	DB2	DB1	DB0
0	0	0	0	0	1	S/C	R/L	X	X

- **S/C: Screen/Cursor select bit**
When S/C="High", Screen is controlled by R/L bit.
When S/C="Low", Cursor is controlled by R/L bit.
- **R/L: Right/Left**
When R/L="High", set direction to right.
When R/L="Low", set direction to left.
Without writing or reading of display data, shift right/left cursor position or display. This instruction is used to correct or search display data. During 2-line mode display, cursor moves to the 2nd line after 40th digit of 1st line. Note that display shift is performed simultaneously in all the line. When displayed data is shifted repeatedly, each line shifted individually. When display shift is performed, the contents of address counter are not changed.

S/C	R/L	Description	AC Value
L	L	Shift cursor to the left	AC=AC-1
L	H	Shift cursor to the right	AC=AC+1
H	L	Shift display to the left. Cursor follows the display shift	AC=AC
H	H	Shift display to the right. Cursor follows the display shift	AC=AC

● **Function Set**

RS	R/W	DB7	DB6	DB5	DB4	DB3	DB2	DB1	DB0
0	0	0	0	1	DL	N	DH	0	IS

➤ **DL : Interface data length control bit**

When DL = "High", it means 8-bit bus mode with MPU.

When DL = "Low", it means 4-bit bus mode with MPU. So to speak, DL is a signal to select 8-bit or 4-bit bus mode.

When in 4-bit bus mode, it needs to transfer 4-bit data by two times.

➤ **N : Display line number control bit**

When N = "High", 2-line display mode is set.

When N = "Low", it means 1-line display mode.

➤ **DH : Double height font type control bit**

When DH = " High " and N= "Low", display font is selected to double height mode(5x16 dot),RAM address can only use 00H~27H.

When DH= "High" and N= "High", it is forbidden.

When DH = " Low ", display font is normal (5x8 dot).

N	DH	EXT option pin connect to high		EXT option pin connect to low	
		Display Lines	Character Font	Display Lines	Character Font
L	L	1	5x8	1	5x8
L	H	1	5x8	1	5x16
H	L	2	5x8	2	5x8
H	H	2	5x8	Forbidden	

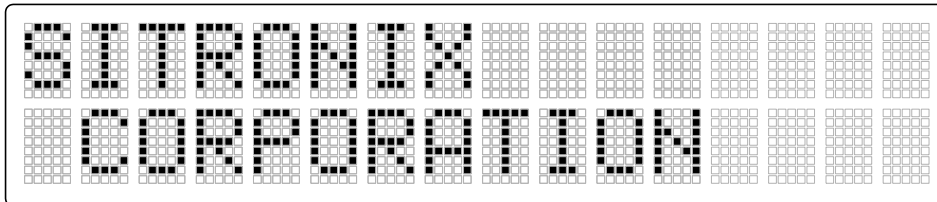

2 line mode normal display (DH=0/N=1)

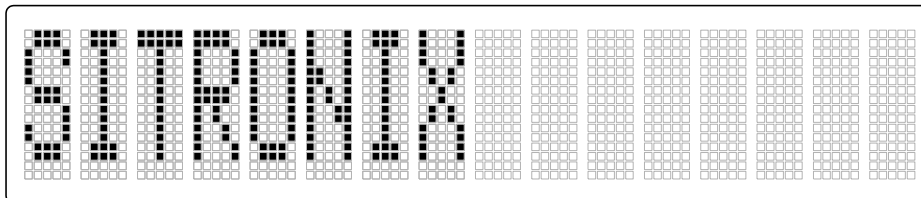

1 line mode with double height font (DH=1/N=0)

➤ **IS : normal/extension instruction select**

When IS=" High", extension instruction be selected (refer extension instruction table)

When IS=" Low", normal instruction be selected (refer normal instruction table)

- **Set CGRAM Address**

RS	R/W	DB7	DB6	DB5	DB4	DB3	DB2	DB1	DB0
0	0	0	1	AC5	AC4	AC3	AC2	AC1	AC0

Set CGRAM address to AC.

This instruction makes CGRAM data available from MPU.

- **Set DDRAM Address**

RS	R/W	DB7	DB6	DB5	DB4	DB3	DB2	DB1	DB0
0	0	1	AC6	AC5	AC4	AC3	AC2	AC1	AC0

Set DDRAM address to AC.

This instruction makes DDRAM data available from MPU.

When 1-line display mode (N = 0), DDRAM address is from "00H" to "4FH".

In 2-line display mode (N = 1), DDRAM address in the 1st line is from "00H" to "27H", and DDRAM address in the 2nd line is from "40H" to "67H".

- **Read Busy Flag and Address**

RS	R/W	DB7	DB6	DB5	DB4	DB3	DB2	DB1	DB0
0	1	BF	AC6	AC5	AC4	AC3	AC2	AC1	AC0

When BF = "High", indicates that the internal operation is being processed. So during this time the next instruction cannot be accepted.

The address Counter (AC) stores DDRAM/CGRAM addresses, transferred from IR.

After writing into (reading from) DDRAM/CGRAM, AC is automatically increased (decreased) by 1.

● Write Data to CGRAM,DDRAM or ICON RAM

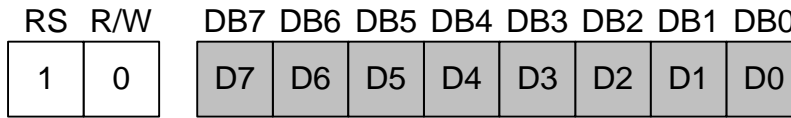

Write binary 8-bit data to **CGRAM, DDRAM or ICON RAM**

The selection of RAM from DDRAM, CGRAM or ICON RAM, is set by the previous address set instruction : DDRAM address set, CGRAM address set, ICON RAM address set. RAM set instruction can also determine the AC direction to RAM.

After write operation, the address is automatically increased/decreased by 1, according to the entry mode.

● Read Data from CGRAM,DDRAM or ICON RAM

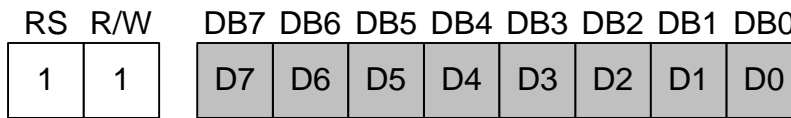

Read binary 8-bit data from DDRAM/CGRAM/ICON RAM

The selection of RAM is set by the previous address set instruction. If address set instruction of RAM is not performed before this instruction, the data that read first is invalid, because the direction of AC is not determined. If you read RAM data several times without RAM address set instruction before read operation, you can get correct RAM data from the second, but the first data would be incorrect, because there is no time margin to transfer RAM data.

※Read data must be “set address” before this instruction.

● **Bias selection/Internal OSC frequency adjust**

RS	R/W	DB7	DB6	DB5	DB4	DB3	DB2	DB1	DB0
0	0	0	0	0	1	BS	F2	F1	F0

➤ **BS: bias selection**

When BS="High", the bias will be 1/4

When BS="Low", the bias will be 1/5

BS will be invalid when external bias resistors are used (OPF1=1, OPF2=1)

➤ **F2,F1,F0 : Internal OSC frequency adjust**

When CLS connect to high, that instruction can adjust OSC and Frame frequency.

Internal frequency adjust			Frame frequency (Hz) (2 line mode)	
F2	F1	F0	VDD = 3.0 V	VDD = 5.0 V
0	0	0	122	120
0	0	1	131	133
0	1	0	144	149
0	1	1	161	167
1	0	0	183	192
1	0	1	221	227
1	1	0	274	277
1	1	1	347	347

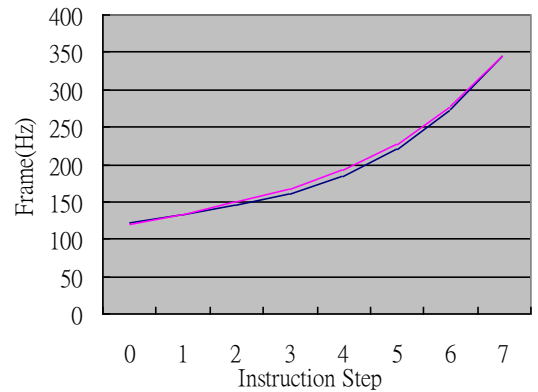

● **Set ICON RAM address**

RS	R/W	DB7	DB6	DB5	DB4	DB3	DB2	DB1	DB0
0	0	0	1	0	0	AC3	AC2	AC1	AC0

Set ICON RAM address to AC.

This instruction makes ICON data available from MPU.

When IS=1 at Extension mode,

The ICON RAM address is from "00H" to "0FH".

● **Power/ICON control/Contrast set(high byte)**

RS	R/W	DB7	DB6	DB5	DB4	DB3	DB2	DB1	DB0
0	0	0	1	0	1	ION	BON	C5	C4

➤ **Ion: set ICON display on/off**

When Ion = "High", ICON display on.

When Ion = "Low", ICON display off.

➤ **Bon: switch booster circuit**

Bon can only be set when internal follower is used (OPF1=0, OPF2=0).

When Bon = "High", booster circuit is turn on.

When Bon = "Low", booster circuit is turn off.

➤ **C5,C4 : Contrast set(high byte)**

C5,C4,C3,C2,C1,C0 can only be set when internal follower is used (OPF1=0,OPF2=0).They can more precisely adjust the input reference voltage of V0 generator. The details please refer to the supply voltage for LCD driver.

- **Follower control**

RS	R/W	DB7	DB6	DB5	DB4	DB3	DB2	DB1	DB0
0	0	0	1	1	0	F _{ON}	Rab 2	Rab 1	Rab 0

- **Fon: switch follower circuit**

Fon can only be set when internal follower is used (OPF1=0,OPF2=0).

When Fon = "High", internal follower circuit is turn on.

When Fon = "Low", internal follower circuit is turn off.

- **Rab2,Rab1,Rab0 : V0 generator amplified ratio**

Rab2,Rab1,Rab0 can only be set when internal follower is used (OPF1=0,OPF2=0).They can adjust the amplified ratio of V0 generator. The details please refer to the supply voltage for LCD driver.

- **Contrast set(low byte)**

RS	R/W	DB7	DB6	DB5	DB4	DB3	DB2	DB1	DB0
0	0	0	1	1	1	C3	C2	C1	C0

- **C3,C2,C1,C0:Contrast set(low byte)**

C5,C4,C3,C2,C1,C0 can only be set when internal follower is used (OPF1=0,OPF2=0).They can more precisely adjust the input reference voltage of V0 generator. The details please refer to the supply voltage for LCD driver.

■ Reset Function

Initializing by Internal Reset Circuit

An internal reset circuit automatically initializes the ST7032 when the power is turned on. The following instructions are executed during the initialization. The busy flag (BF) is kept in the busy state (BF = 1) until the initialization ends. The busy state lasts for 40 ms after VDD rises to stable.

1. Display clear
2. Function set:
 - DL = 1; 8-bit interface data
 - N = 0; 1-line display
 - DH=0; normal 5x8 font
 - IS=0; use instruction table 0
3. Display on/off control:
 - D = 0; Display off
 - C = 0; Cursor off
 - B = 0; Blinking off
4. Entry mode set:
 - I/D = 1; Increment by 1
 - S = 0; No shift
5. Internal OSC frequency
 - (F2,F1,F0)=(1,0,0)
6. ICON control
 - Ion=0; ICON off
7. Power control
 - BS=0; 1/5bias
 - Bon=0; booster off
 - Fon=0; follower off
 - (C5,C4,C3,C2,C1,C0)=(1,0,0,0,0,0)
 - (Rab2,Rab1,Rab0)=(0,1,0)

Note:

If the electrical characteristics conditions listed under the table Power Supply Conditions Using Internal Reset Circuit are not met, the internal reset circuit will not operate normally and will fail to initialize the ST7032.

When internal Reset Circuit not operate, ST7032 can be reset by XRESET pin from MPU control signal.

■ Initializing by Instruction

- 8-bit Interface (fosc=380KHz)

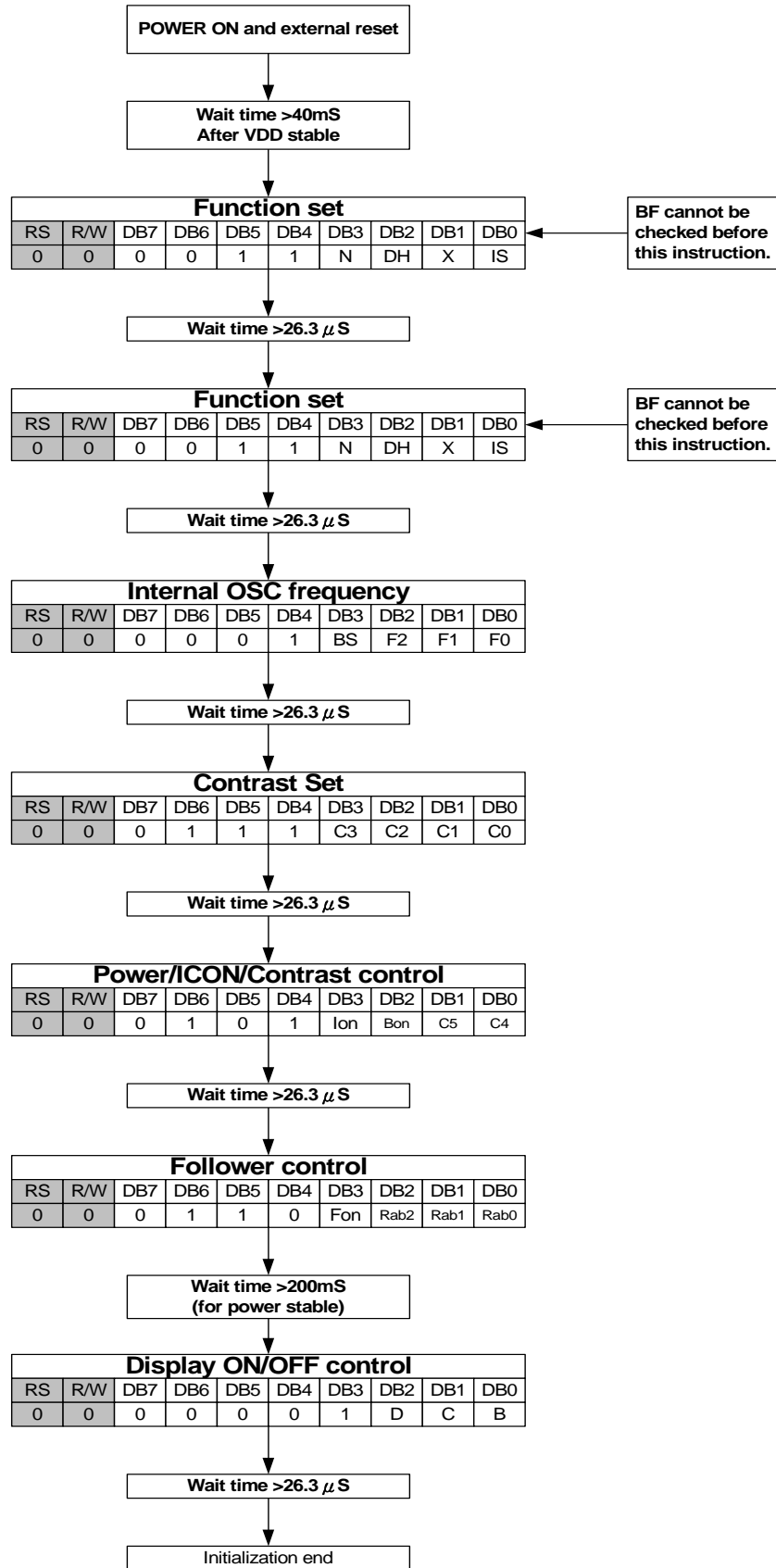

➤ **Initial Program Code Example For 8051 MPU(8 Bit Interface):**

```

;-----
INITIAL_START:
    CALL  HARDWARE_RESET
    CALL  DELAY40mS
    MOV   A,#38H           ;FUNCTION SET
    CALL  WRINS_NOCHK     ;8 bit,N=1,5*7dot
    CALL  DELAY30uS
    MOV   A,#39H           ;FUNCTION SET
    CALL  WRINS_NOCHK     ;8 bit,N=1,5*7dot,IS=1
    CALL  DELAY30uS
    MOV   A,#14H          ;Internal OSC frequency adjustment
    CALL  WRINS_CHK
    CALL  DELAY30uS
    MOV   A,#78H          ; Contrast control
    CALL  WRINS_CHK
    CALL  DELAY30uS
    MOV   A,#5EH          ;Power/ICON/Contrast control
    CALL  WRINS_CHK
    CALL  DELAY30uS
    MOV   A,#6AH          ;Follower control
    CALL  WRINS_CHK
    CALL  DELAY200mS      ;for power stable
    MOV   A,#0CH          ;DISPLAY ON
    CALL  WRINS_CHK
    CALL  DELAY30uS
    MOV   A,#01H          ;CLEAR DISPLAY
    CALL  WRINS_CHK
    CALL  DELAY2mS
    MOV   A,#06H          ;ENTRY MODE SET
    CALL  WRINS_CHK      ;CURSOR MOVES TO RIGHT
    CALL  DELAY30uS

```

```

;-----
MAIN_START:
    XXXX
    XXXX
    XXXX
    XXXX

```

```

;-----
WRINS_CHK:
    CALL  CHK_BUSY
WRINS_NOCHK:
    CLR   RS               ;EX:Port 3.0
    CLR   RW               ;EX:Port 3.1
    SETB  E                ;EX:Port 3.2
    MOV   P1,A             ;EX:Port 1=Data Bus
    CLR   E
    MOV   P1,#FFH         ;For Check Busy Flag
    RET

```

```

;-----
CHK_BUSY:                                ;Check Busy Flag
    CLR   RS
    SETB  RW
    SETB  E
    JB    P1.7,$
    CLR   E
    RET

```

● 4-bit Interface (fosc=380KHz)

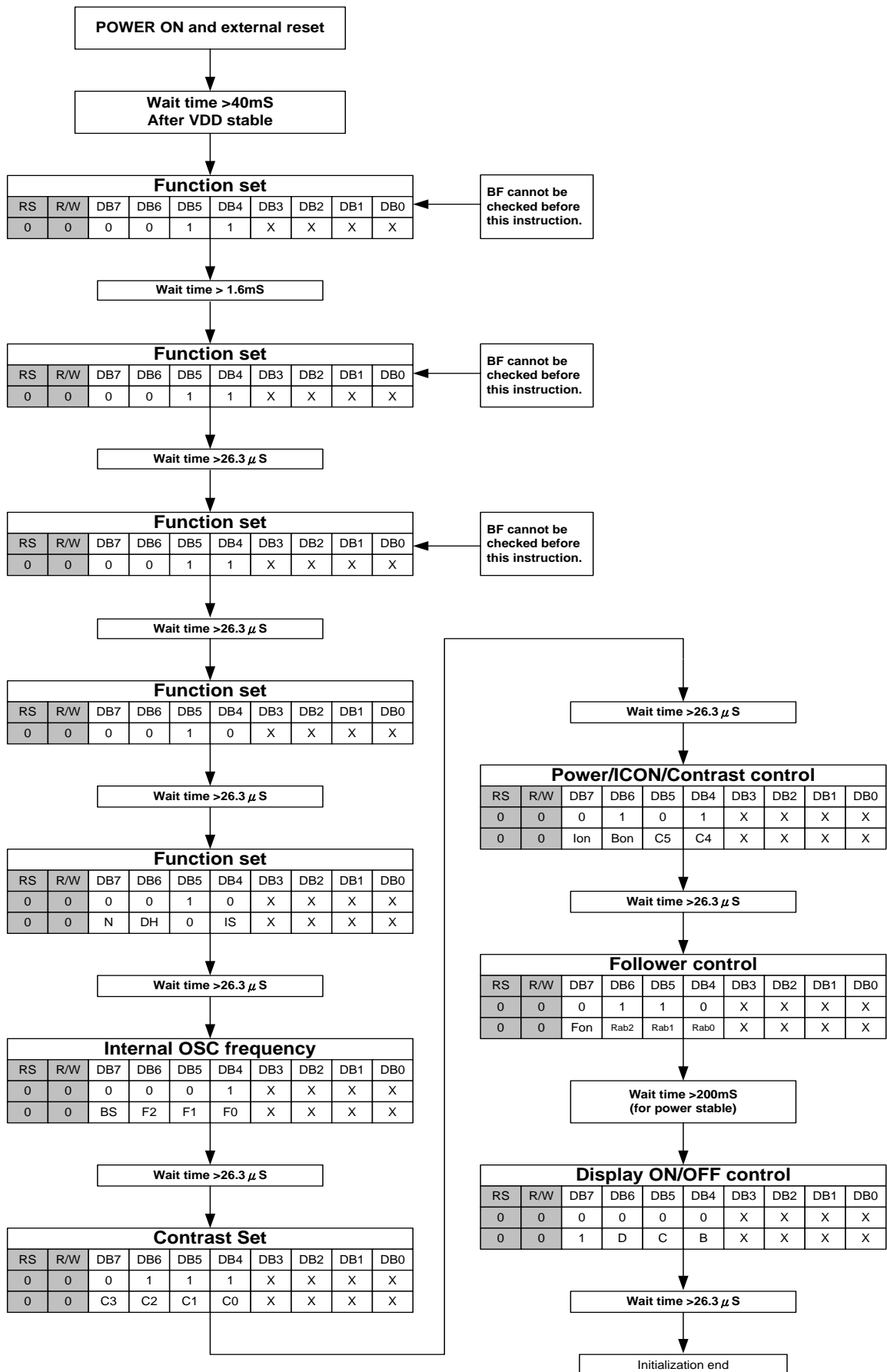

➤ Initial Program Code Example For 8051 MPU(4 Bit Interface):

```

;-----
INITIAL_START:
    CALL  HARDWARE_RESET
    CALL  DELAY40mS
    MOV   A,#38H           ;FUNCTION SET
    CALL  WRINS_ONCE      ;8 bit, 5*7 dot
    CALL  DELAY2mS

    MOV   A,#38H           ;FUNCTION SET
    CALL  WRINS_ONCE      ;8 bit, 5*7 dot
    CALL  DELAY30uS

    MOV   A,#38H           ;FUNCTION SET
    CALL  WRINS_ONCE      ;8 bit, 5*7 dot
    CALL  DELAY30uS

    CALL  CHK_BUSY
    MOV   A,#28H           ;FUNCTION SET
    CALL  WRINS_ONCE      ; 4 bit, 5*7 dot
    CALL  DELAY30uS

    MOV   A,#29H           ;FUNCTION SET
    CALL  WRINS_CHK       ; 4 bit N = 1, 5*7 dot
    CALL  DELAY30uS      ; IS = 1

    MOV   A,#14H           ;Internal OSC
    CALL  WRINS_CHK
    CALL  DELAY30uS

    MOV   A,#78H           ;Contrast set
    CALL  WRINS_CHK
    CALL  DELAY30uS

    MOV   A,#5EH           ;Power/ICON/Contrast
    CALL  WRINS_CHK
    CALL  DELAY30uS

    MOV   A,#6AH           ;Follower control
    CALL  WRINS_CHK
    CALL  DELAY200mS     ;For power stable

    MOV   A,#0CH           ;DISPLAY ON
    CALL  WRINS_CHK
    CALL  DELAY30uS

    MOV   A,#01H           ;CLEAR DISPLAY
    CALL  WRINS_CHK
    CALL  DELAY2mS

    MOV   A,#06H           ;ENTRY MODE SET
    CALL  WRINS_CHK
    CALL  DELAY30uS

;-----
MAIN_START:
    XXXX
    XXXX
    XXXX
    .

```

```

.
.
.
;-----
WRINS_CHK:
    CALL  CHK_BUSY
WRINS_NOCHK:
    PUSH  A
    ANL  A,#F0H
    CLR  RS           ;EX:Port 3.0
    CLR  RW           ;EX:Port 3.1
    SETB E           ;EX:Port 3.2
    MOV  P1,A        ;EX:Port1=Data Bus
    CLR  E
    POP  A
    SWAP A
WRINS_ONCE:
    ANL  A,#F0H
    CLR  RS
    CLR  RW
    SETB E
    MOV  P1,A
    CLR  E
    MOV  P1,#FFH;For Check Bus Flag
    RET

;-----
CHK_BUSY:           ;Check Busy Flag
    PUSH  A
    MOV  P1,#FFH
$1
    CLR  RS
    SETB RW
    SETB E
    MOV  A,P1
    CLR  E
    MOV  P1,#FFH
    CLR  RS
    SETB RW
    SETB E
    NOP
    CLR  E
    JB   A.7,$1
    POP  A
    RET

```

- Serial interface & IIC interface (fosc = 380KHz)

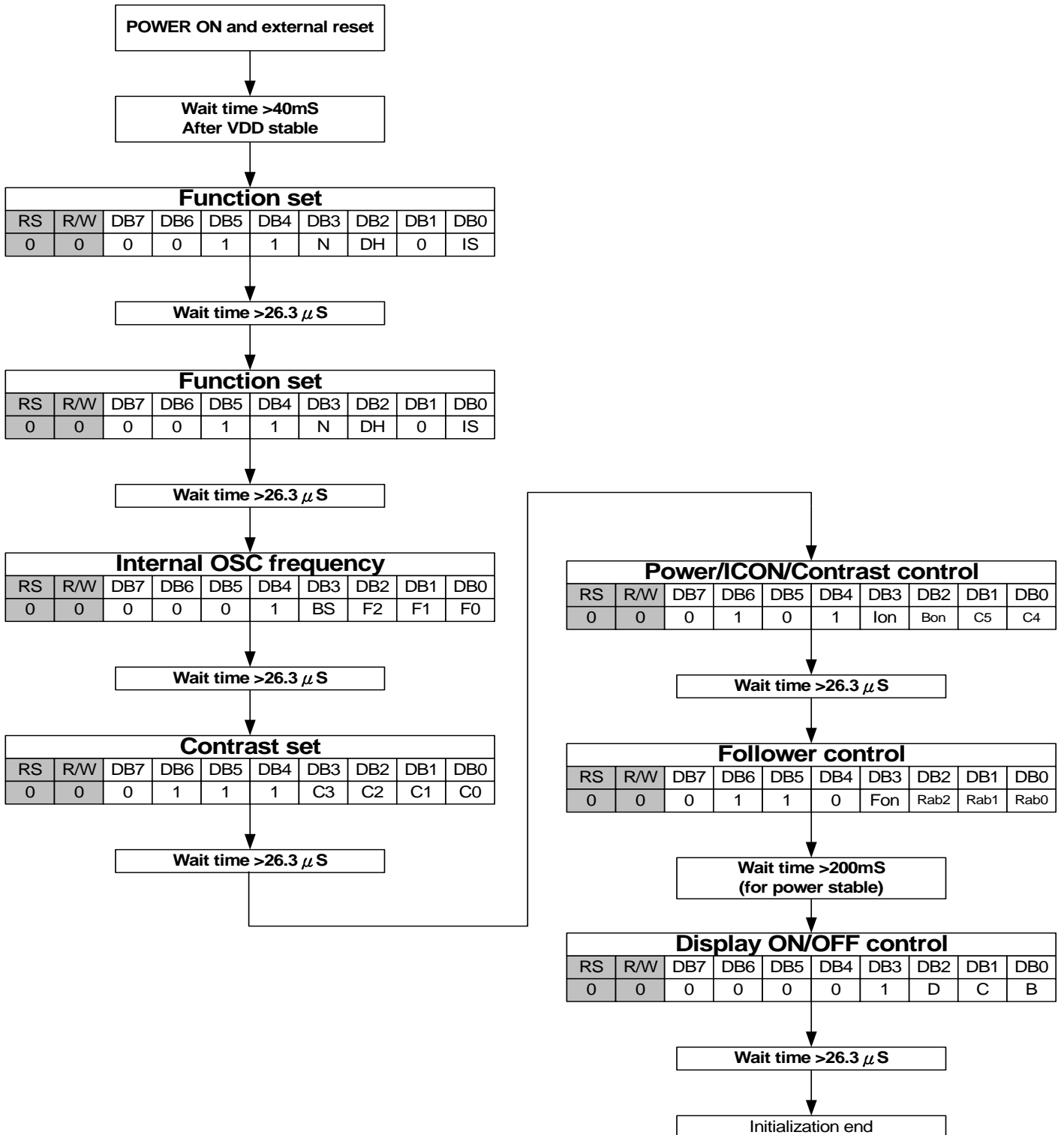

➤ **Initial Program Code Example For 8051 MPU(Serial Interface):**

INITIAL_START:

```

CALL  HARDWARE_RESET
CALL  DELAY40mS
MOV   A,#38H           ;FUNCTION SET
CALL  WRINS_NOCHK     ;8 bit,N=1,5*7dot
CALL  DELAY30uS
MOV   A,#39H           ;FUNCTION SET
CALL  WRINS_NOCHK     ;8 bit,N=1,5*7dot,IS=1
CALL  DELAY30uS
MOV   A,#14H          ;Internal OSC frequency adjustment
CALL  WRINS_NOCHK
CALL  DELAY30uS
MOV   A,#78H          ;Contrast set
CALL  WRINS_NOCHK
CALL  DELAY30uS
MOV   A,#5EH          ;Power/ICON/Contrast control
CALL  WRINS_NOCHK
CALL  DELAY30uS
MOV   A,#6AH          ;Follower control
CALL  WRINS_NOCHK
CALL  DELAY200mS      ;for power stable
MOV   A,#0CH          ;DISPLAY ON
CALL  WRINS_NOCHK
CALL  DELAY30uS
MOV   A,#01H          ;CLEAR DISPLAY
CALL  WRINS_NOCHK
CALL  DELAY2mS
MOV   A,#06H          ;ENTRY MODE SET
CALL  WRINS_NOCHK    ;CURSOR MOVES TO RIGHT
CALL  DELAY30uS

```

MAIN_START:

```

XXXX
XXXX
XXXX
XXXX
.
.
.

```

WRINS_NOCHK:

```

PUSH  1
MOV   R1,#8
CLR   RS
$1
RLC   A
MOV   SI,C
SET   SCL
NOP
CLR   SCL
DJNZ  R1,$1
POP   1

CALL  DLY1.5mS
RET

```

■ Interfacing to the MPU

The ST7032 can send data in two 4-bit operations/one 8-bit operation, serial 1 bit operation or fast I²C operation, thus allowing interfacing with 4-bit, 8-bit or I²C MPU.

- **For 4-bit interface data, only four bus lines (DB4 to DB7) are used for transfer.** Bus lines DB0 to DB3 are disabled. The data transfer between the ST7032 and the MPU is completed after the 4-bit data has been transferred twice. As for the order of data transfer, the four high order bits (for 8-bit operation, DB4 to DB7) are transferred before the four low order bits (for 8-bit operation, DB0 to DB3). The busy flag must be checked (one instruction) after the 4-bit data has been transferred twice. Two more 4-bit operations then transfer the busy flag and address counter data.

➤ Example of busy flag check timing sequence

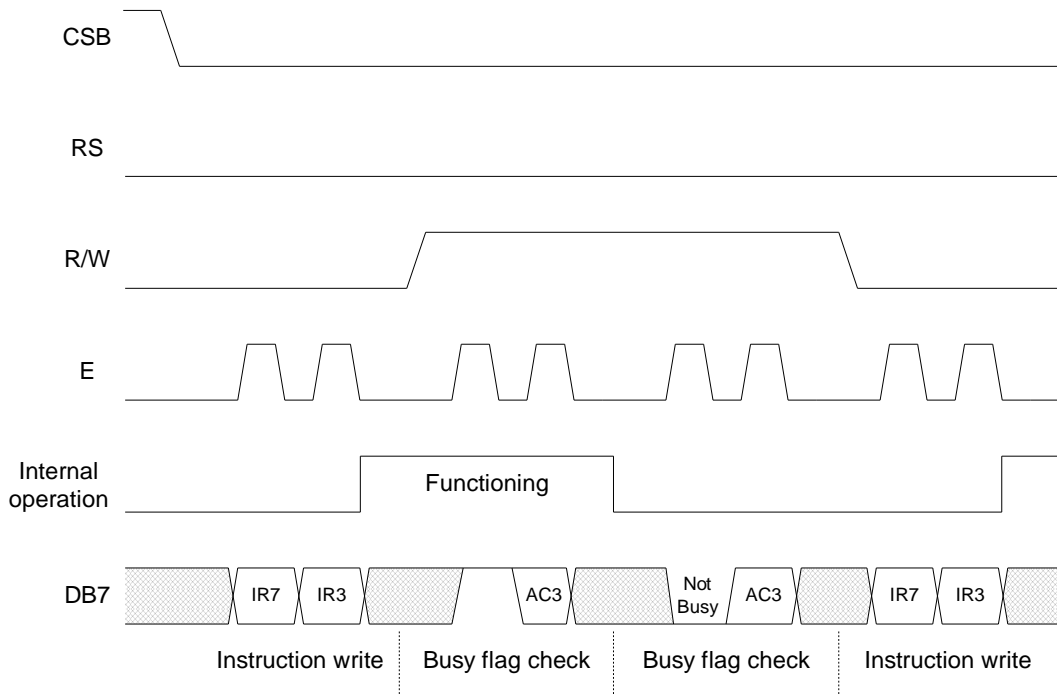

➤ Intel 8051 interface(4 Bit)

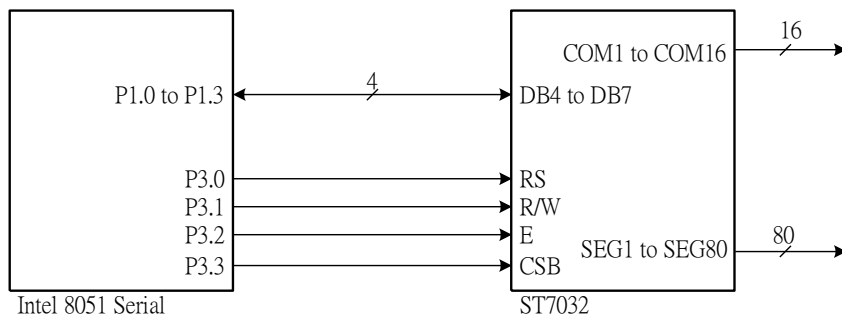

- For 8-bit interface data, all eight bus lines (DB0 to DB7) are used.

➤ Example of busy flag check timing sequence

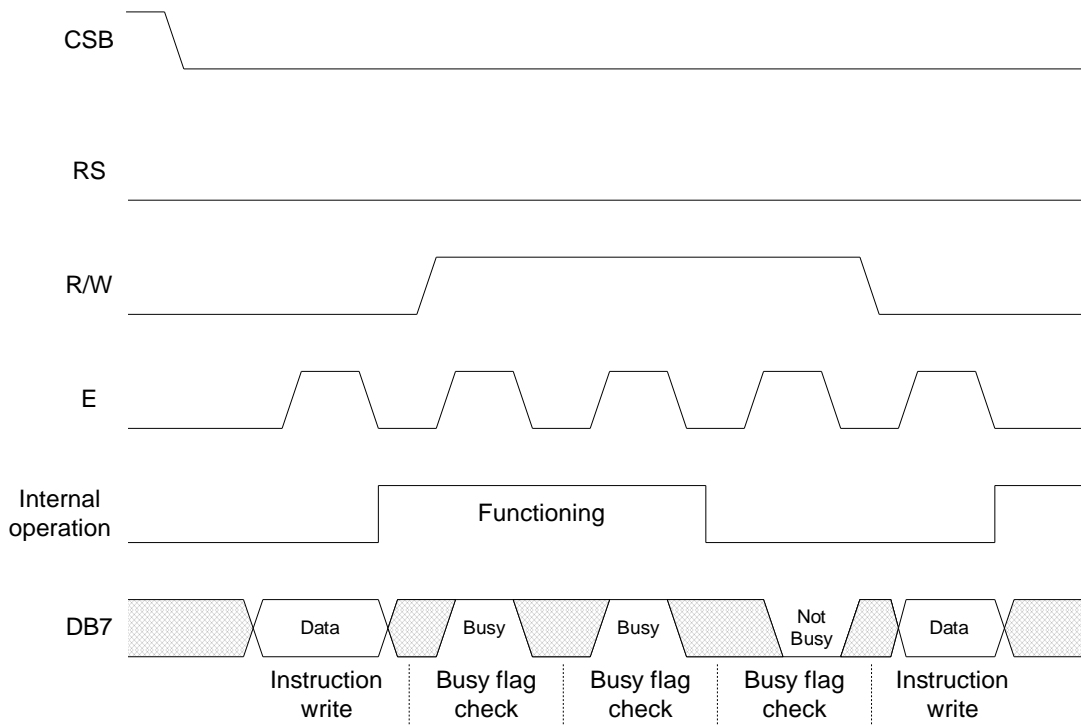

➤ Intel 8051 interface(8 Bit)

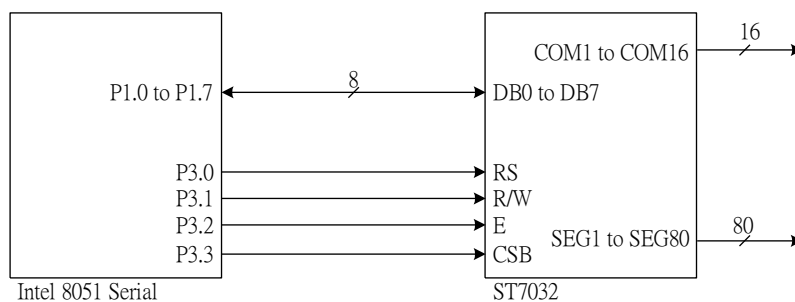

- For serial interface data, only two bus lines (DB6 to DB7) are used.

➤ Example of timing sequence

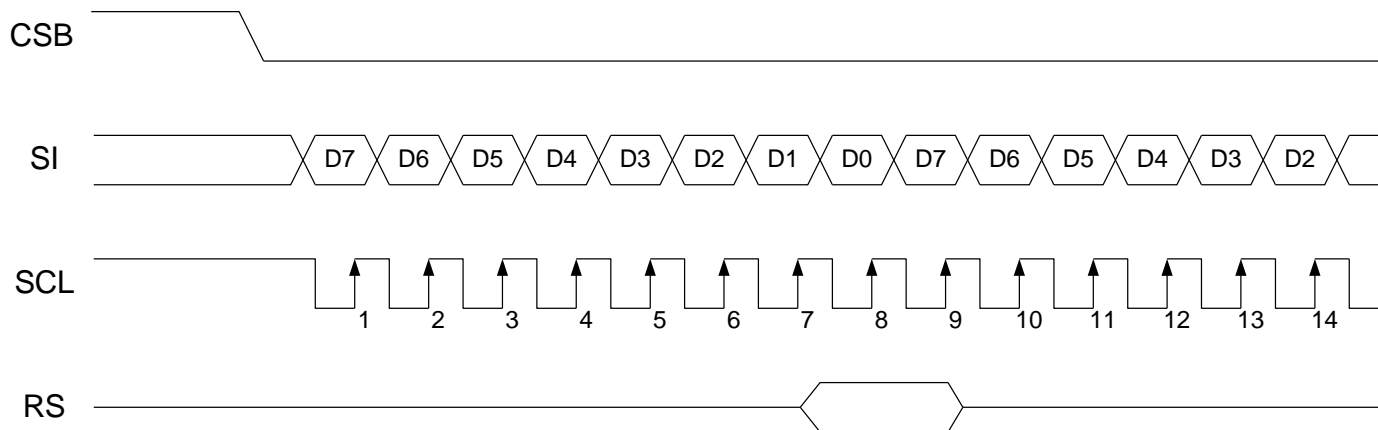

Note: The falling edge must cause on CSB before the serial clock (SCL) active.

➤ Intel 8051 interface(Serial)

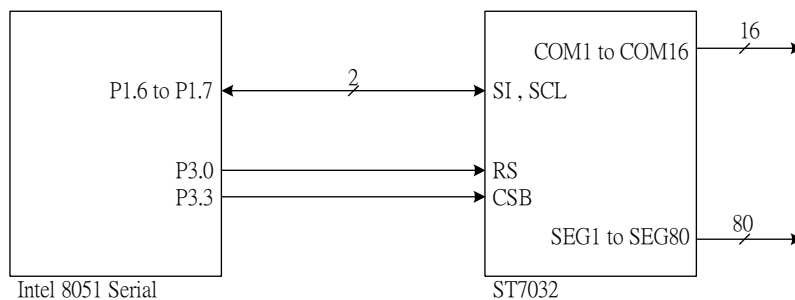

- For I²C interface data, only two bus lines (DB6 to DB7) are used.

➤ Example of timing sequence

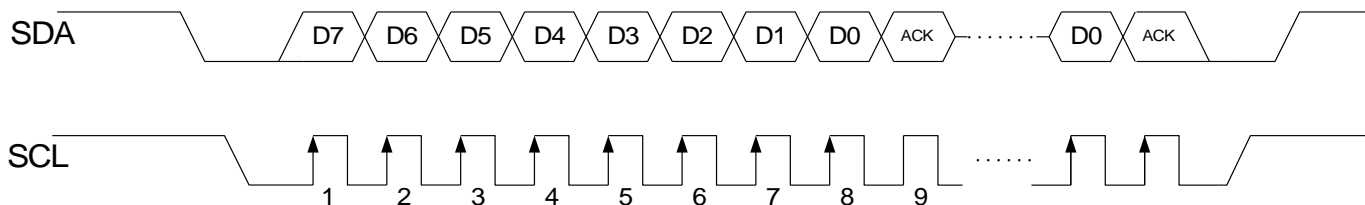

➤ Intel 8051 interface(I²C)

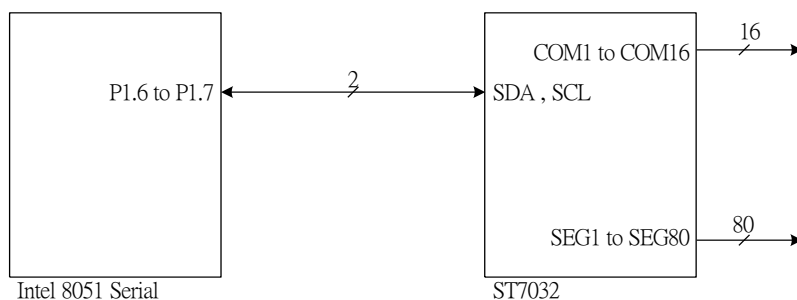

Supply Voltage for LCD Drive

- When external bias resistors are used
(OPF1=1,OPF2=1)

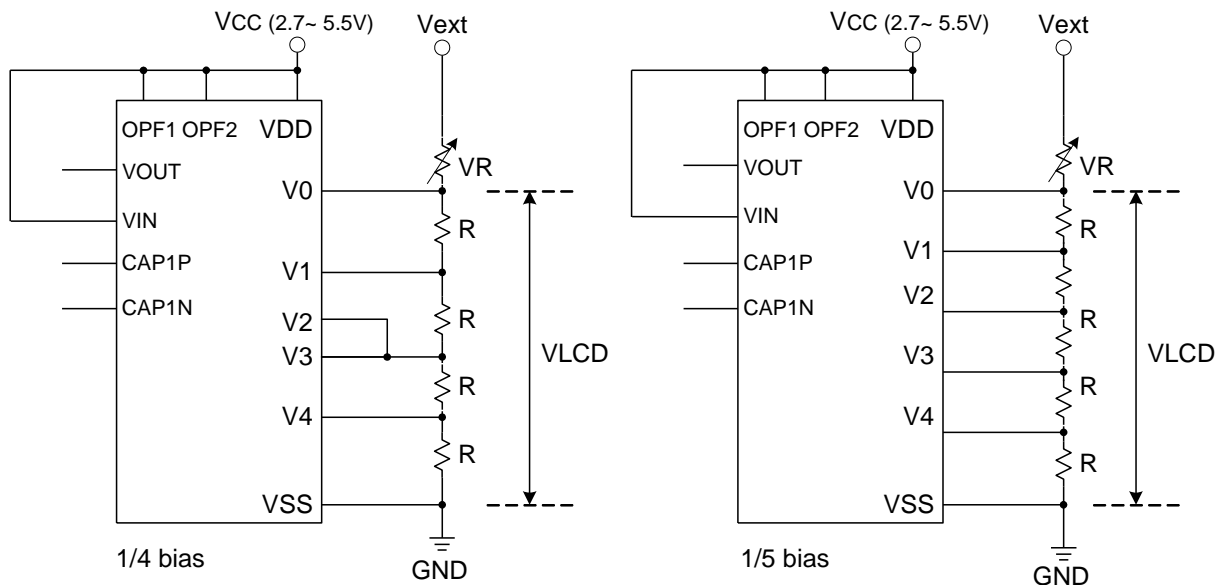

- When built-in bias resistors(9.6KΩ) are used
(OPF1=1,OPF2=0)

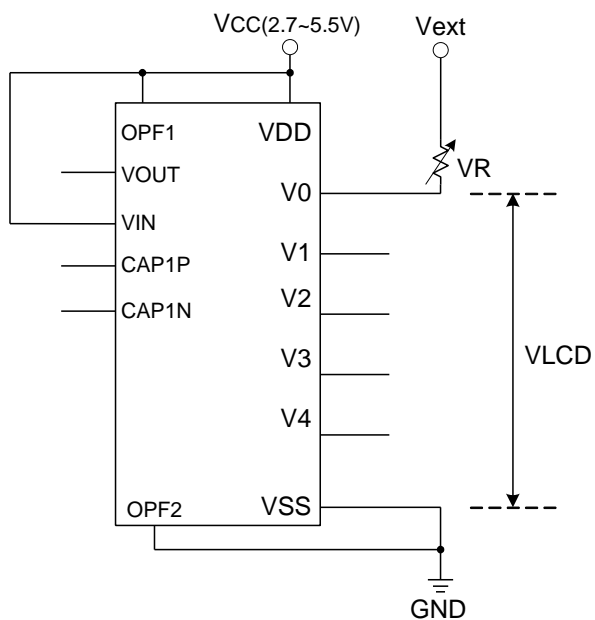

- When built-in bias resistors(3.3KΩ) are used
(OPF1=0,OPF2=1)

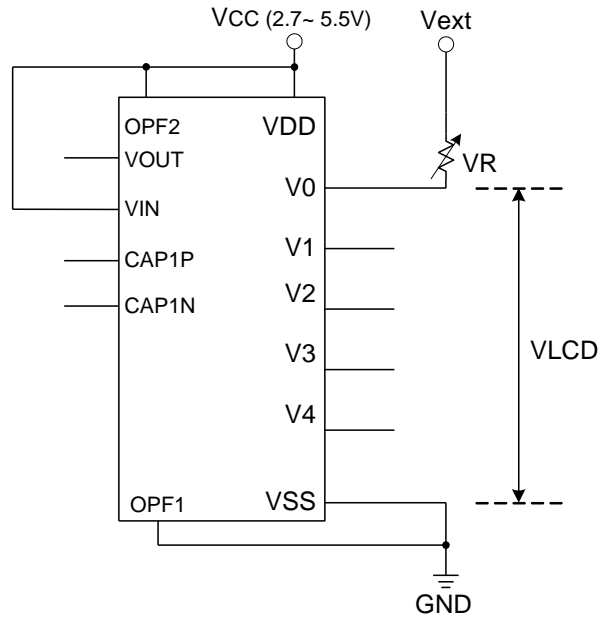

- When built-in voltage followers with external Vout are used
(OPF1=0,OPF2=0 and instruction setting Bon=0,Fon=1)

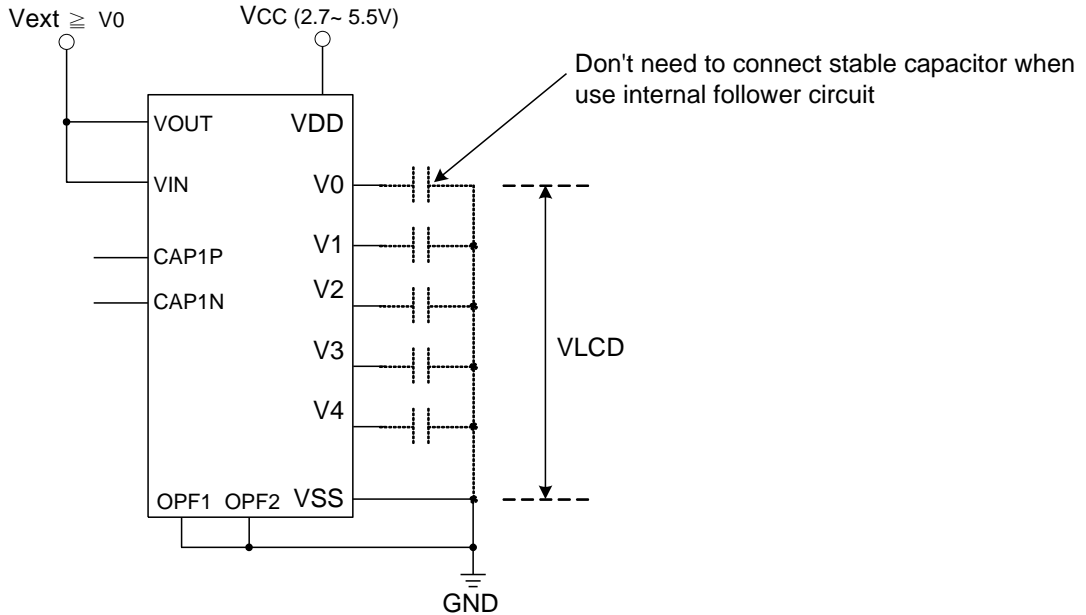

- When built-in booster and voltage followers are used(OPF1=0,OPF2=0)

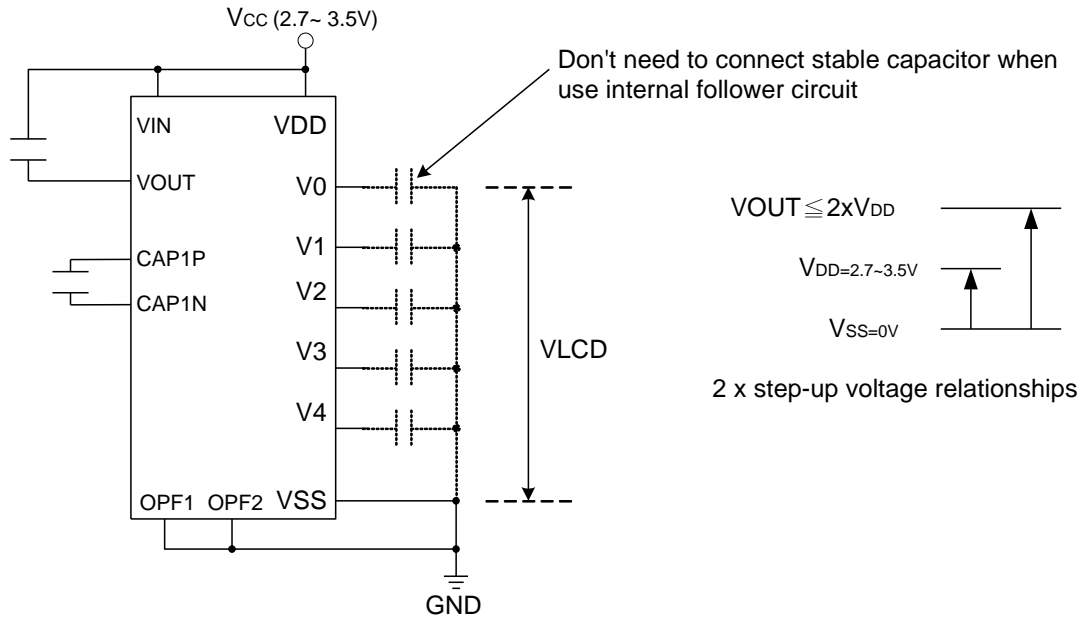

Note:

Ensure V0 level stable, that must let $|V_{out}-V_0|$ over 0.5V(if panel size over 4.5",the $|V_{out}-V_0|$ propose over 0.8V).

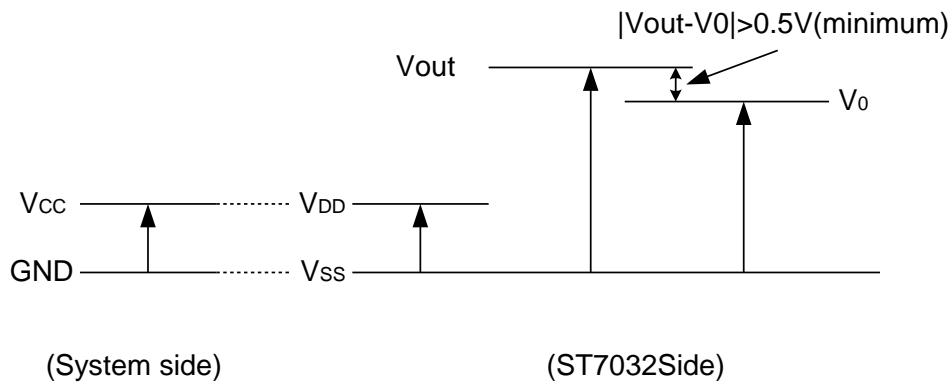

➤ V0 voltage follower value calculation

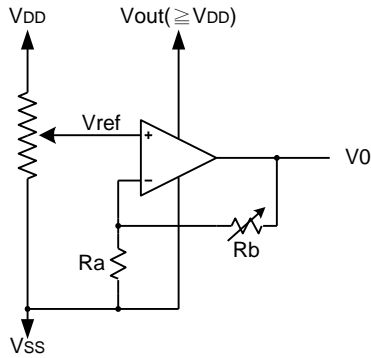

$$V0 = (1 + \frac{Rb}{Ra}) * Vref$$

$$\text{While } Vref = VDD * (\frac{\alpha + 36}{100})$$

C5	C4	C3	C2	C1	C0	α
0	0	0	0	0	0	0
0	0	0	0	0	1	1
0	0	0	0	1	0	2
⋮						⋮
1	1	1	1	0	1	61
1	1	1	1	1	0	62
1	1	1	1	1	1	63

Rab2	Rab1	Rab0	1+Rb/Ra
0	0	0	1
0	0	1	1.25
0	1	0	1.5
0	1	1	1.8
1	0	0	2
1	0	1	2.5
1	1	0	3
1	1	1	3.75

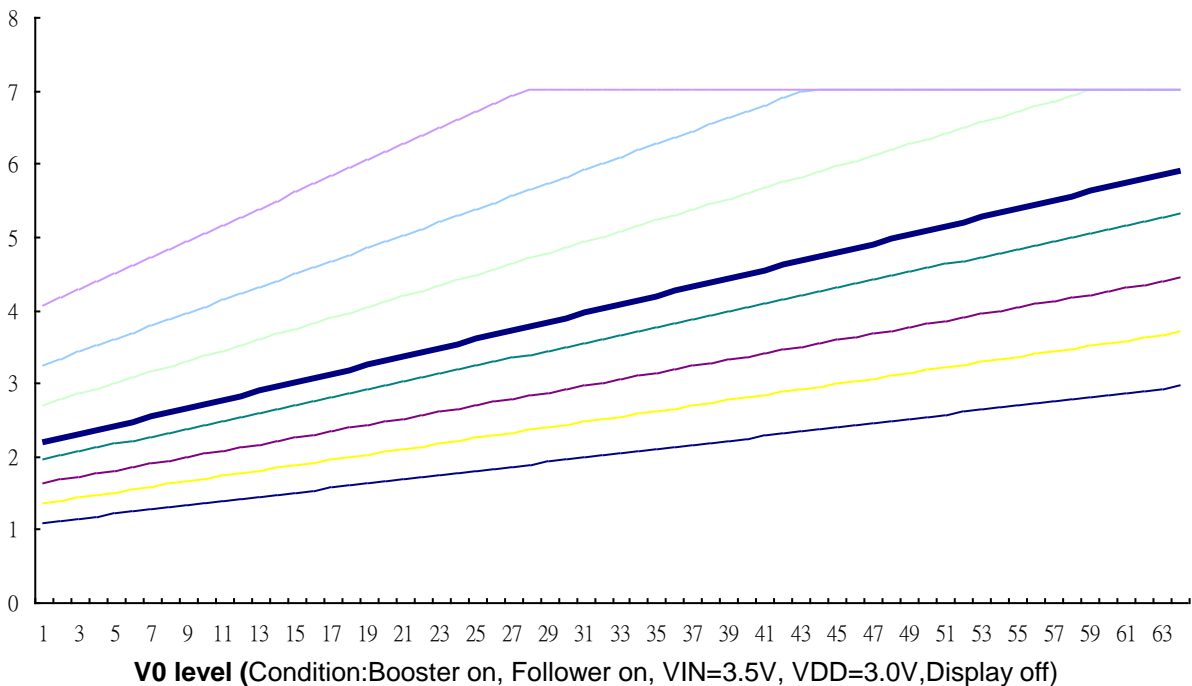

The recommended curve: follower = 04H

Notes:

1. $Vout \geq V0 \geq V1 \geq V2 \geq V3 \geq V4 \geq Vss$ must be maintained.
2. If the calculation value of V0 is higher than Vout, the real V0 value will saturate to Vout.
3. internal built-in booster can only be used when OPF1=0,OPF2=0.

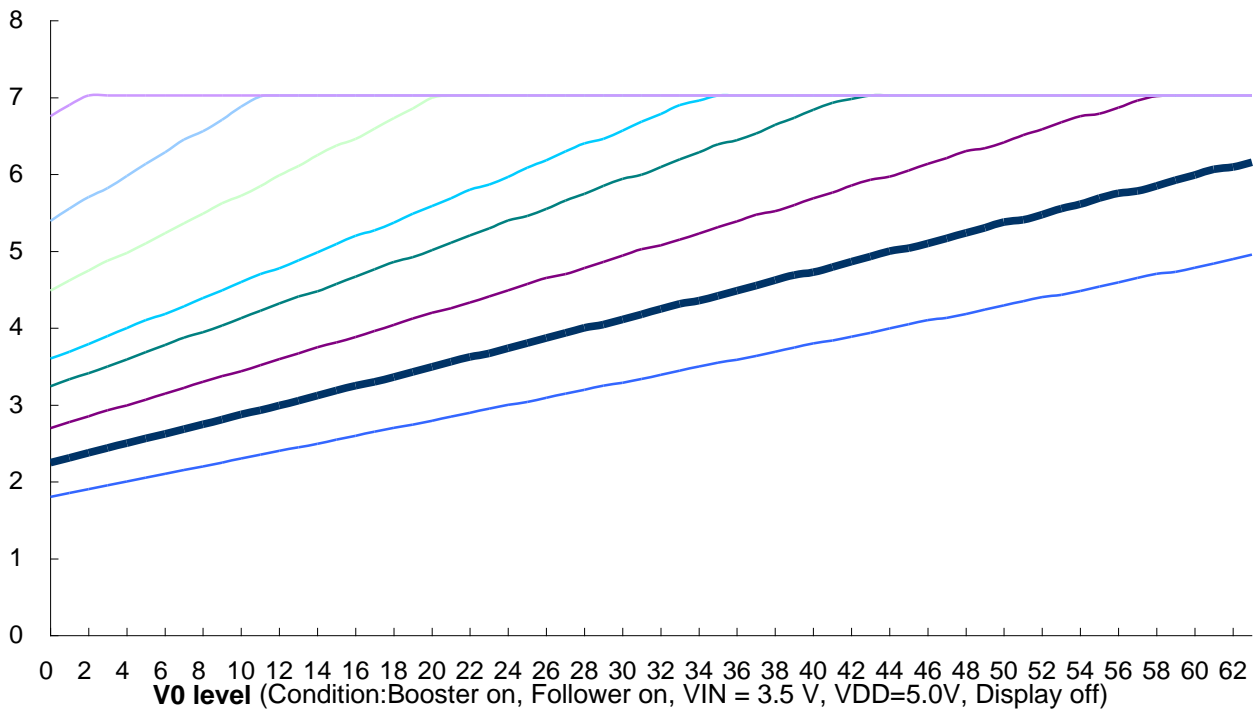

The recommended curve: follower = 01H

Notes:

1. $V_{out} \geq V_0 \geq V_1 \geq V_2 \geq V_3 \geq V_4 \geq V_{SS}$ must be maintained.
2. If the calculation value of V_0 is higher than V_{out} , the real V_0 value will saturate to V_{out} .
3. internal built-in booster can only be used when $OPF1=0, OPF2=0$.

AC Characteristics

68 Interface

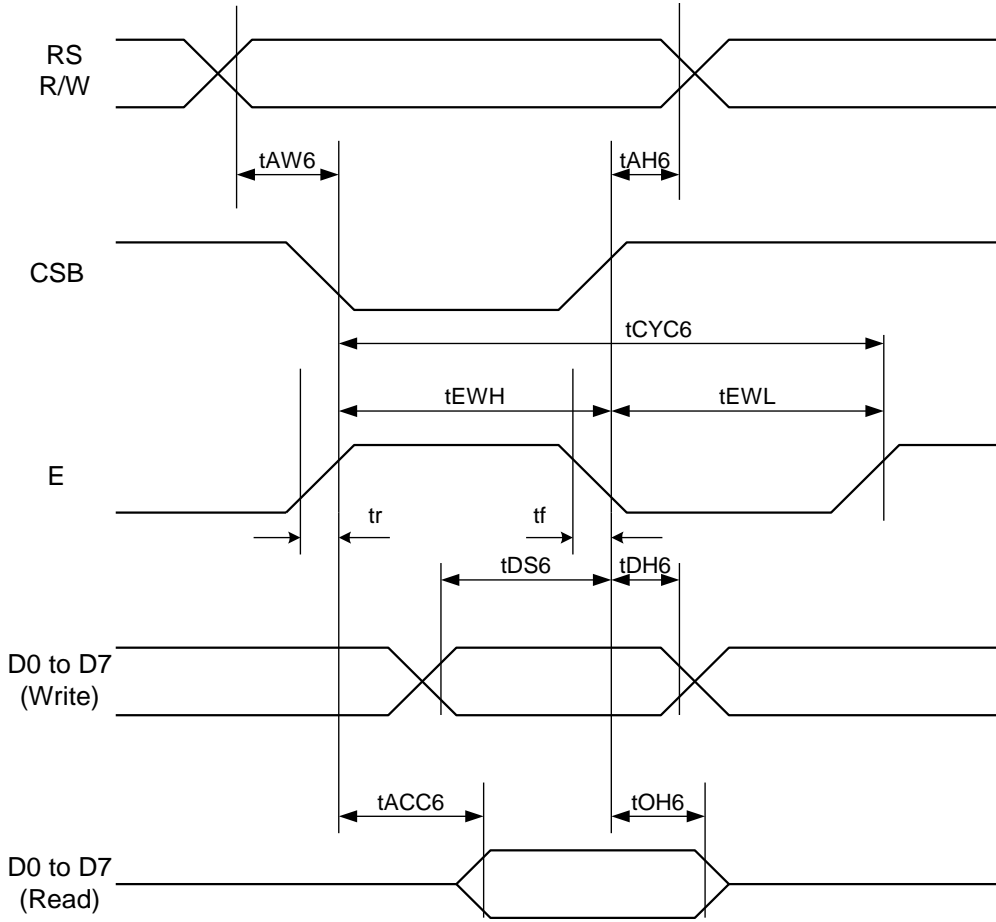

($T_a = 25^\circ\text{C}$)

Item	Signal	Symbol	Condition	VDD=2.7 to 4.5V Rating		VDD=4.5 to 5.5V Rating		Units
				Min.	Max.	Min.	Max.	
Address hold time	RS	t_{AH6}	—	20	-	20	-	ns
Address setup time	RS	t_{AW6}		20	-	20	-	
System cycle time	RS	t_{CYC6}	—	400	-	280	-	ns
Data setup time	D0 to D7	t_{DS6}	—	100	-	80	-	ns
Data hold time	D0 to D7	t_{DH6}		40	-	20	-	
Access time	D0 to D7	t_{ACC6}	CL = 100 pF	-	500	-	400	ns
Output disable time	D0 to D7	t_{OH6}		300	-	150	-	
Enable Rise/Fall time	E	t_r, t_f	—	-	20	-	20	ns
Enable H pulse time	E	t_{EWH}	—	200	-	120	-	ns
Enable L pulse time	E	t_{EWL}	—	150	-	130	-	ns

Note: All timing is specified using 20% and 80% of VDD as the reference.

● Serial Interface

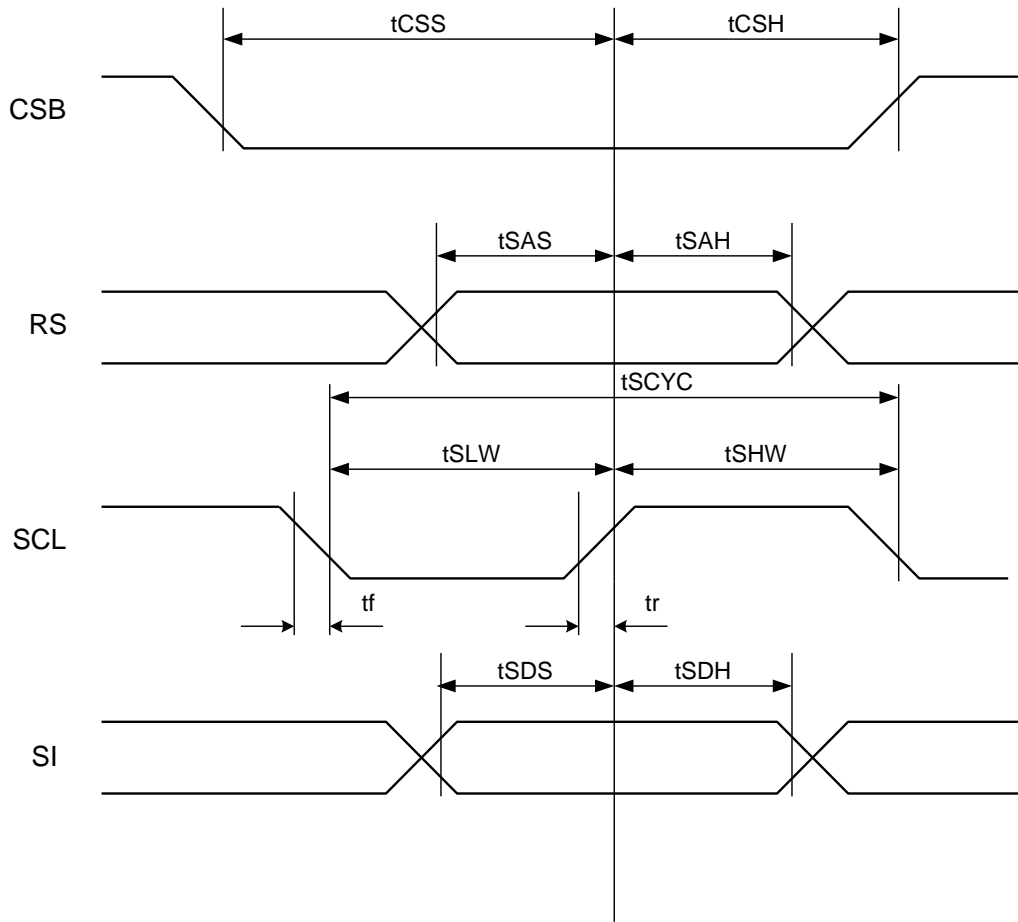

(Ta = 25°C)

Item	Signal	Symbol	Condition	VDD=2.7 to 4.5V Rating		VDD=4.5 to 5.5V Rating		Units
				Min.	Max.	Min.	Max.	
Serial Clock Period	SCL	tSCYC	—	200	-	100	-	ns
SCL "H" pulse width		tSHW		20	-	20	-	
SCL "L" pulse width		tSLW		160	-	120	-	
SCL Rise/Fall time	SCL	tr,tf	—	-	20	-	20	ns
Address setup time	RS	tsAS	—	10	-	10	-	ns
Address hold time		tsAH		250	-	150	-	
Data setup time	SI	tSDS	—	10	-	10	-	ns
Data hold time		tSDH		10	-	20	-	
CS-SCL time	CS	tcSS	—	20	-	20	-	ns
		tcSH		350	-	200	-	

*1 All timing is specified using 20% and 80% of VDD as the standard.

● I2C interface

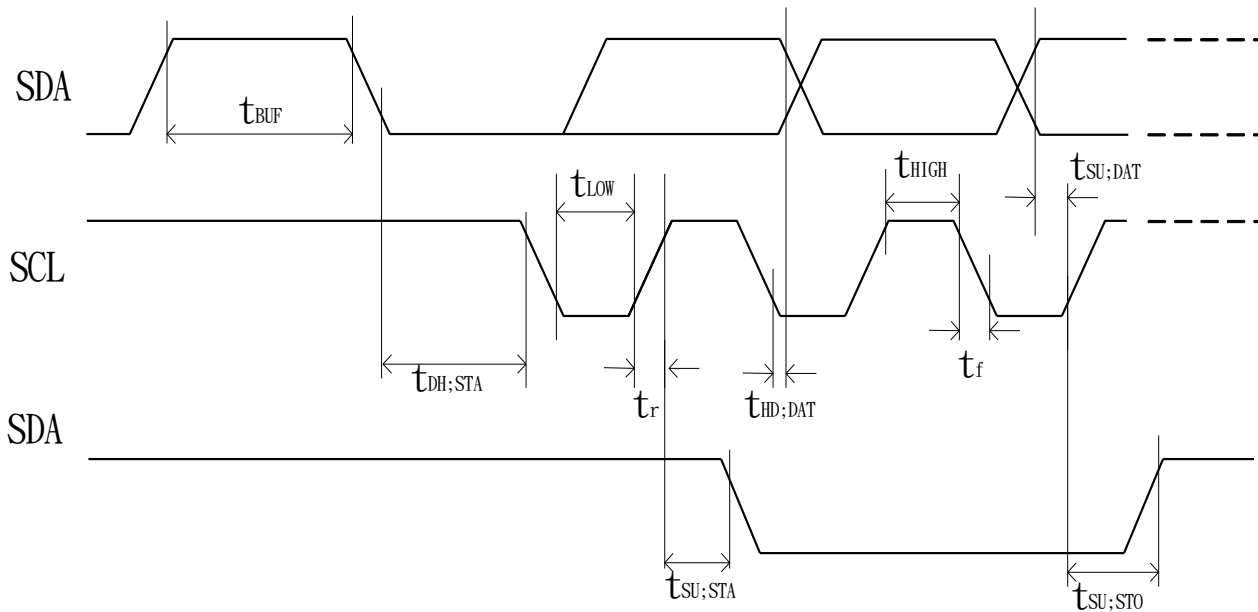

(Ta = 25°C)

Item	Signal	Symbol	Condition	VDD=2.7 to 4.5V Rating		VDD=4.5 to 5.5V Rating		Units
				Min.	Max.	Min.	Max.	
SCL clock frequency	SCL	f_{SCLK}	—	DC	400	DC	400	KHz
SCL clock low period		t_{LOW}	—	1.3	—	1.3	—	us
SCL clock high period		t_{HIGH}	—	0.6	—	0.6	—	us
Data set-up time	SI	$t_{SU;DAT}$	—	180	—	100	—	ns
Data hold time		$t_{HD;DAT}$	—	0	0.9	0	0.9	us
SCL,SDA rise time	SCL, SDA	t_r	—	$20+0.1C_b$	300	$20+0.1C_b$	300	ns
SCL,SDA fall time		t_f	—	$20+0.1C_b$	300	$20+0.1C_b$	300	
Capacitive load represent by each bus line		C_b	—	—	400	—	400	pf
Setup time for a repeated START condition	SI	$t_{SU;STA}$	—	0.6	—	0.6	—	us
Start condition hold time		$t_{HD;STA}$	—	0.6	—	0.6	—	us
Setup time for STOP condition		$t_{SU;STO}$	—	0.6	—	0.6	—	us
Bus free time between a Stop and START condition	SCL	t_{BUF}	—	1.3	—	1.3	—	us

● Internal Power Supply Reset

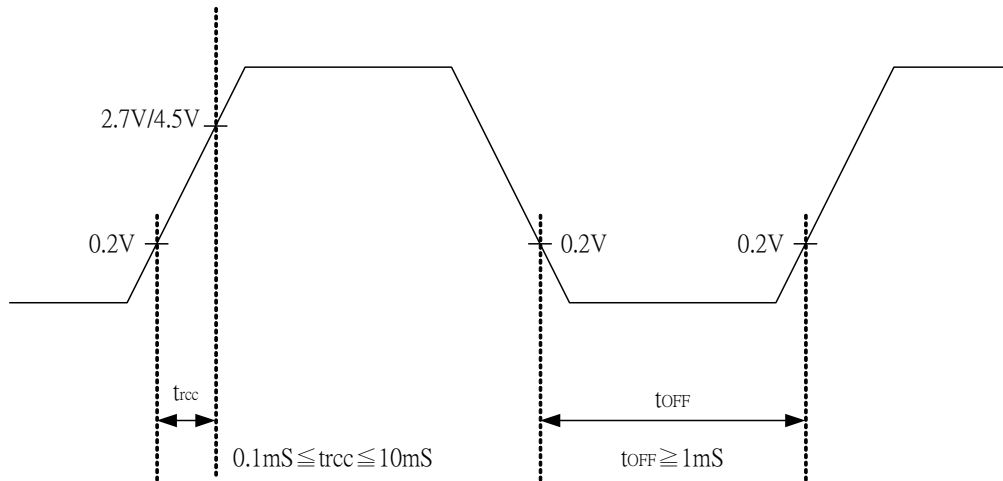

Notes:

- ◆ t_{off} compensates for the power oscillation period caused by momentary power supply oscillations.
- ◆ Specified at 4.5V for 5V operation, and at 2.7V for 3V operation.
- ◆ If 2.7V/4.5V is not reached during 3V/5V operation, internal reset circuit will not operate normally.

● Hardware reset(XRESET)

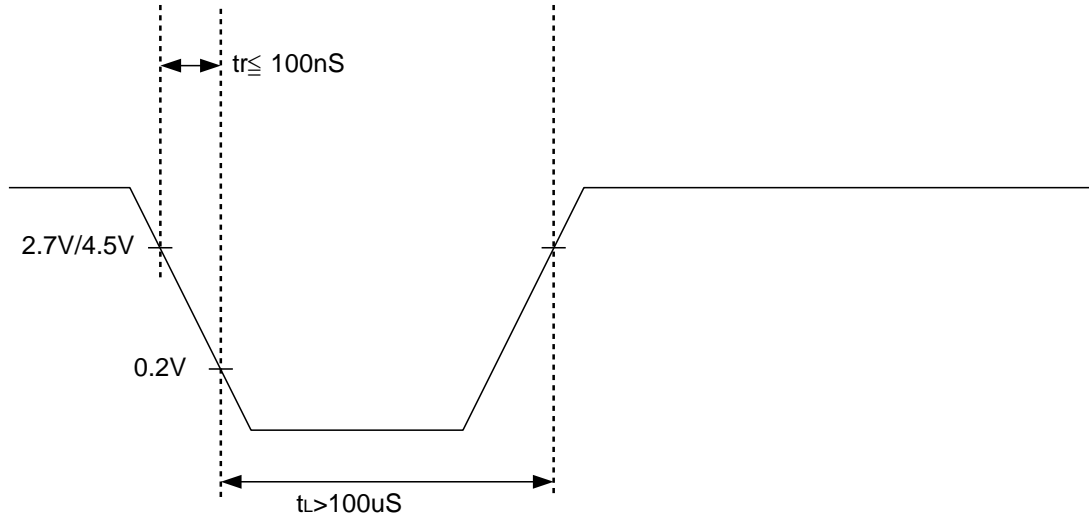

■ Absolute Maximum Ratings

Characteristics	Symbol	Value
Power Supply Voltage	VDD	-0.3 to +6.0
LCD Driver Voltage	V _{LCD}	7.0- V _{SS} to -0.3+V _{SS}
Input Voltage	V _{IN}	-0.3 to VDD+0.3
Operating Temperature	T _A	-30°C to + 85°C
Storage Temperature	T _{STO}	-65°C to + 150°C

Notes:

1. Stresses exceed the Absolute Limiting Values listed above may cause permanent damage to IC. These values are stresses only. IC should be operated under DC/AC Characteristics condition for normal operation. If this condition is not met, IC operation may be error and the reliability may be deteriorated.
2. Parameters are valid over operating temperature range unless otherwise specified. All voltages are with respect to VSS unless otherwise noted.
3. Semiconductor devices are sensitive to light and this IC is not designed to meet light protection requirements. Therefore, in order to prevent this IC from malfunctioning due to light, caution should be taken to avoid exposure of this IC to any light source during normal operation.

■ DC Characteristics

(TA = 25°C , VDD = 2.7 V – 4.5 V)

Symbol	Characteristics	Test Condition	Min.	Typ.	Max.	Unit
VDD	Operating Voltage	-	2.7	-	4.5	V
V _{LCD}	LCD Voltage	V ₀ -V _{SS}	2.7	-	7.0	V
V _{IN}	Power Supply	-	-	-	3.5	V
I _{CC}	Power Supply Current	VDD=3.0V (Use internal booster/follower circuit)	-	160	230	uA
V _{IH1}	Input High Voltage (Except OSC1)	-	1.9	-	VDD	V
V _{IL1}	Input Low Voltage (Except OSC1)	-	- 0.3	-	0.8	V
V _{IH2}	Input High Voltage (OSC1)	-	0.7 VDD	-	VDD	V
V _{IL2}	Input Low Voltage (OSC1)	-	-	-	0.2 VDD	V
V _{OH1}	Output High Voltage (DB0 - DB7)	I _{OH} = -1.0mA	0.75 VDD	-	-	V
V _{OL1}	Output Low Voltage (DB0 - DB7)	I _{OL} = 1.0mA	-	-	0.8	V
V _{OH2}	Output High Voltage (Except DB0 - DB7)	I _{OH} = -0.04mA	0.8 VDD	-	VDD	V
V _{OL2}	Output Low Voltage (Except DB0 - DB7)	I _{OL} = 0.04mA	-	-	0.2 VDD	V
R _{COM}	Common Resistance	V _{LCD} = 4V, I _d = 0.05mA	-	2	20	KΩ
R _{SEG}	Segment Resistance	V _{LCD} = 4V, I _d = 0.05mA	-	2	30	KΩ
I _{LEAK}	Input Leakage Current	V _{IN} = 0V to VDD	-1	-	1	μA
I _{PUP}	Pull Up MOS Current	VDD = 3V	20	30	40	μA
f _{OSC}	Oscillation frequency	VDD = 3V, 1/17duty	350	540	1100	KHz

■ DC Characteristics

(TA = 25°C, VDD = 4.5 V - 5.5 V)

Symbol	Characteristics	Test Condition	Min.	Typ.	Max.	Unit
VDD	Operating Voltage	-	4.5	-	5.5	V
V _{LCD}	LCD Voltage	V ₀ -V _{ss}	2.7	-	7.0	V
V _{IN}	Power Supply	-	-	-	3.5	V
I _{CC}	Power Supply Current	VDD=5.0V (Use internal booster/follower circuit)	-	240	340	uA
V _{IH1}	Input High Voltage (Except OSC1)	-	2.7	-	VDD	V
V _{IL1}	Input Low Voltage (Except OSC1)	-	-0.3	-	0.8	V
V _{IH2}	Input High Voltage (OSC1)	-	0.7 VDD	-	VDD	V
V _{IL2}	Input Low Voltage (OSC1)	-	-	-	1.0	V
V _{OH1}	Output High Voltage (DB0 - DB7)	I _{OH} = -1.0mA	3.8	-	VDD	V
V _{OL1}	Output Low Voltage (DB0 - DB7)	I _{OL} = 1.0mA	-	-	0.8	V
V _{OH2}	Output High Voltage (Except DB0 - DB7)	I _{OH} = -0.04mA	0.8 VDD	-	VDD	V
V _{OL2}	Output Low Voltage (Except DB0 - DB7)	I _{OL} = 0.04mA	-	-	0.2 VDD	V
R _{COM}	Common Resistance	V _{LCD} = 4V, I _d = 0.05mA	-	2	20	KΩ
R _{SEG}	Segment Resistance	V _{LCD} = 4V, I _d = 0.05mA	-	2	30	KΩ
I _{LEAK}	Input Leakage Current	V _{IN} = 0V to VDD	-1	-	1	μA
I _{PUP}	Pull Up MOS Current	VDD = 5V	65	95	125	μA
f _{OSC}	Oscillation frequency	VDD = 5V, 1/17duty	350	540	1100	KHz

■ LCD Frame Frequency

- 1/16 Duty(ST7066U normal mode); Assume the oscillation frequency is 540KHZ, 1 clock cycle = 1.85us, 1/16 duty; 1/5 bias, 1 frame = 1.85us x 200 x 16 = 5.92ms=168.9Hz(SHLC and SHLS connect to High)

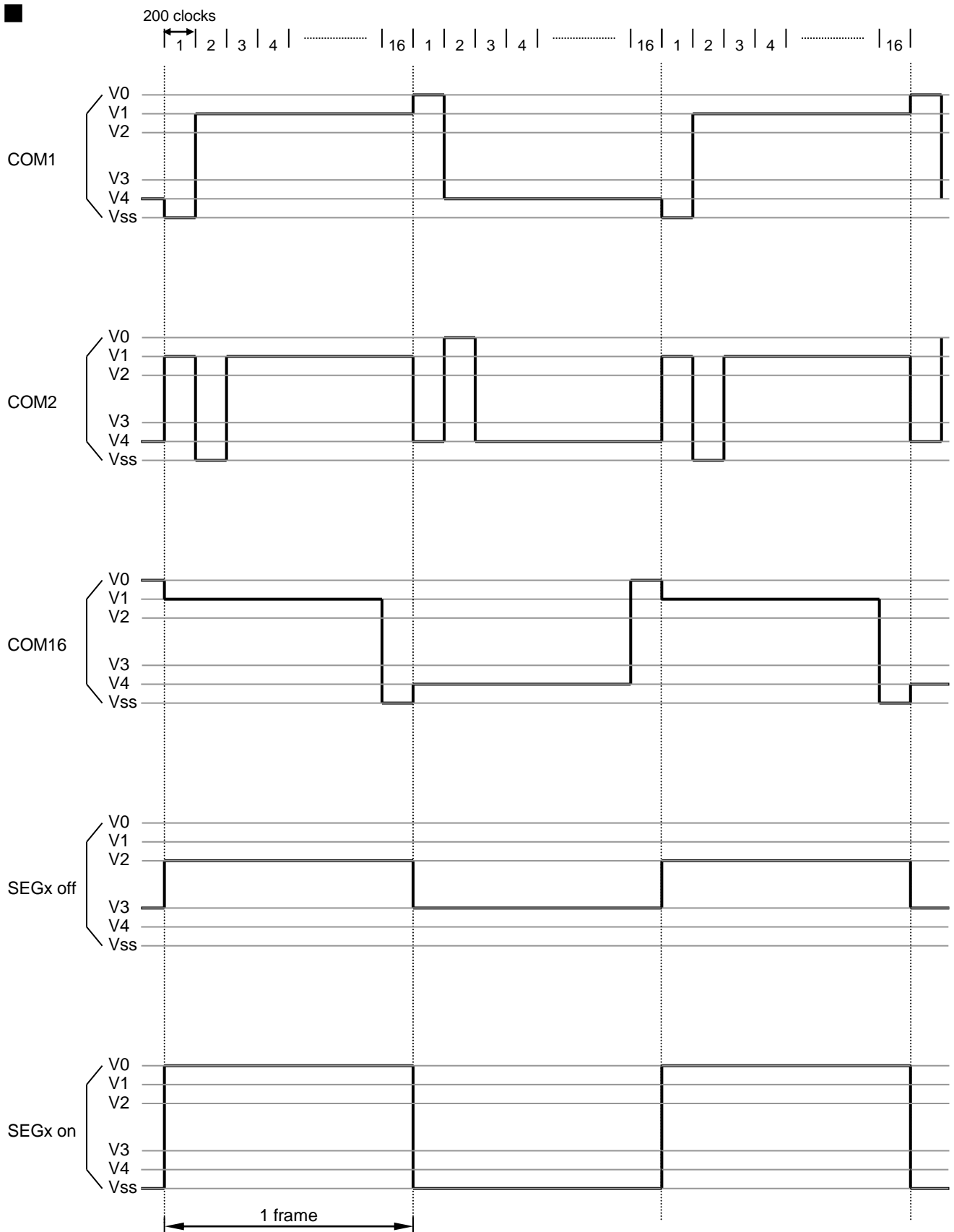

- 1/17 Duty(Extension mode); Assume the oscillation frequency is 540KHZ, 1 clock cycle time = 1.85us, 1/17 duty; 1/5 bias, 1 frame = 1.85us x 200 x 17 = 6.29ms=159Hz(SHLC and SHLS connect to High)

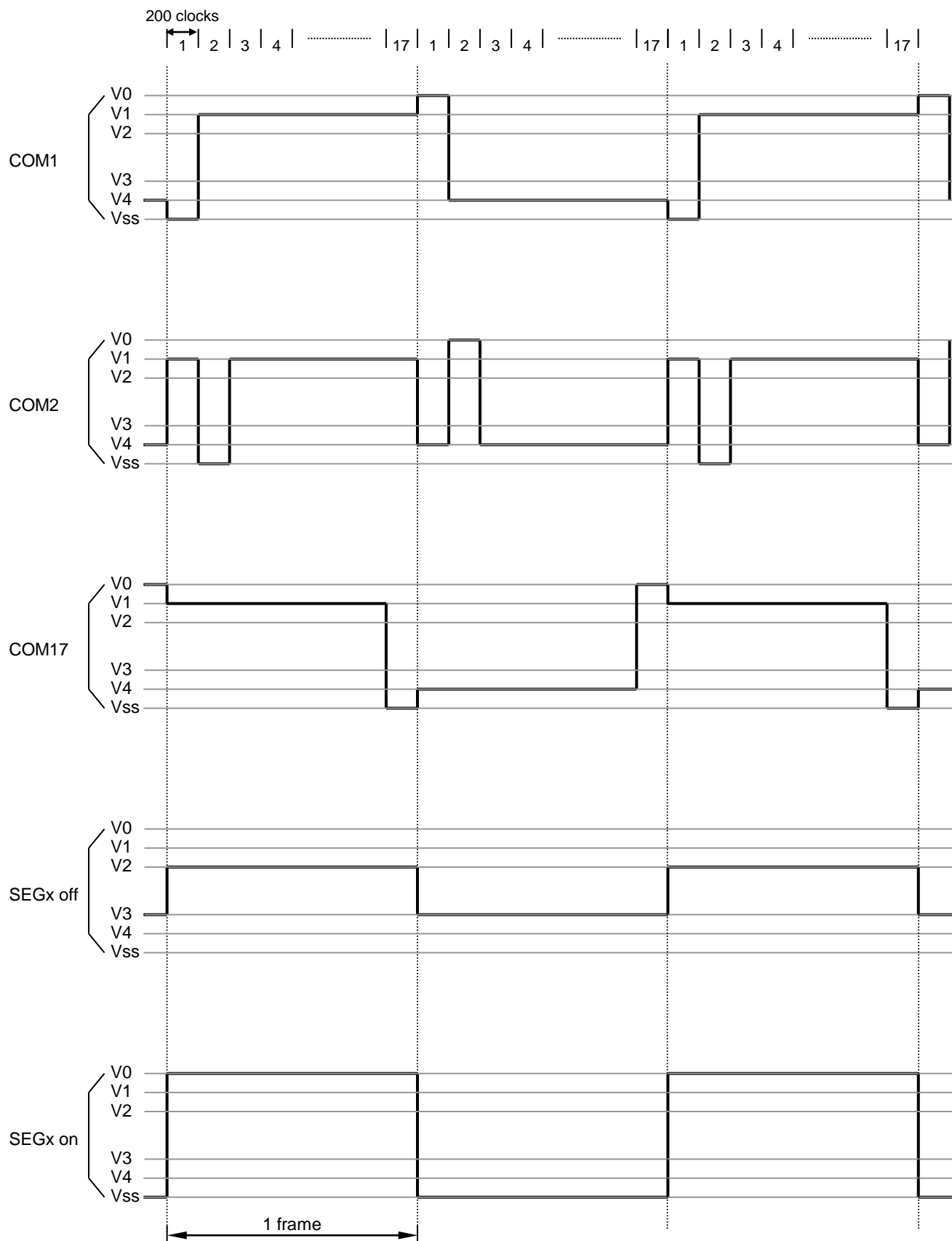

- 1/8 Duty(ST7066U normal mode); Assume the oscillation frequency is 540KHZ, 1 clock cycle time = 1.85us, 1/8 duty; 1/4 bias,1 frame = 1.85us x 400 x 8 = 5.92ms=168.9Hz(SHLC and SHLS connect to

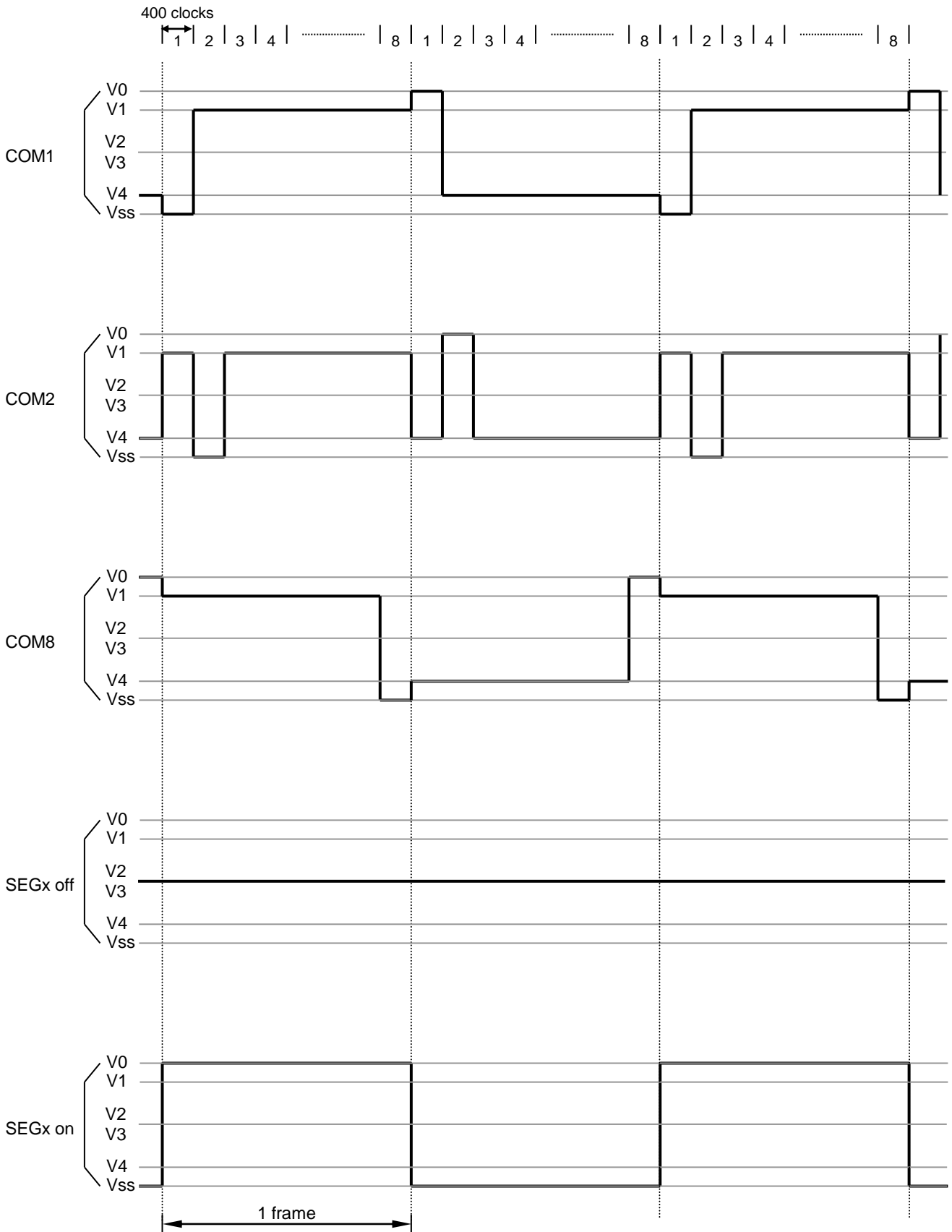

High)

- 1/9 Duty(Extension mode); Assume the oscillation frequency is 540KHZ, 1 clock cycle time = 1.85us, 1/9 duty; 1/4 bias, 1 frame = 1.85us x 400 x 9 = 6.66ms=150Hz(SHLC and SHLS connect to High)

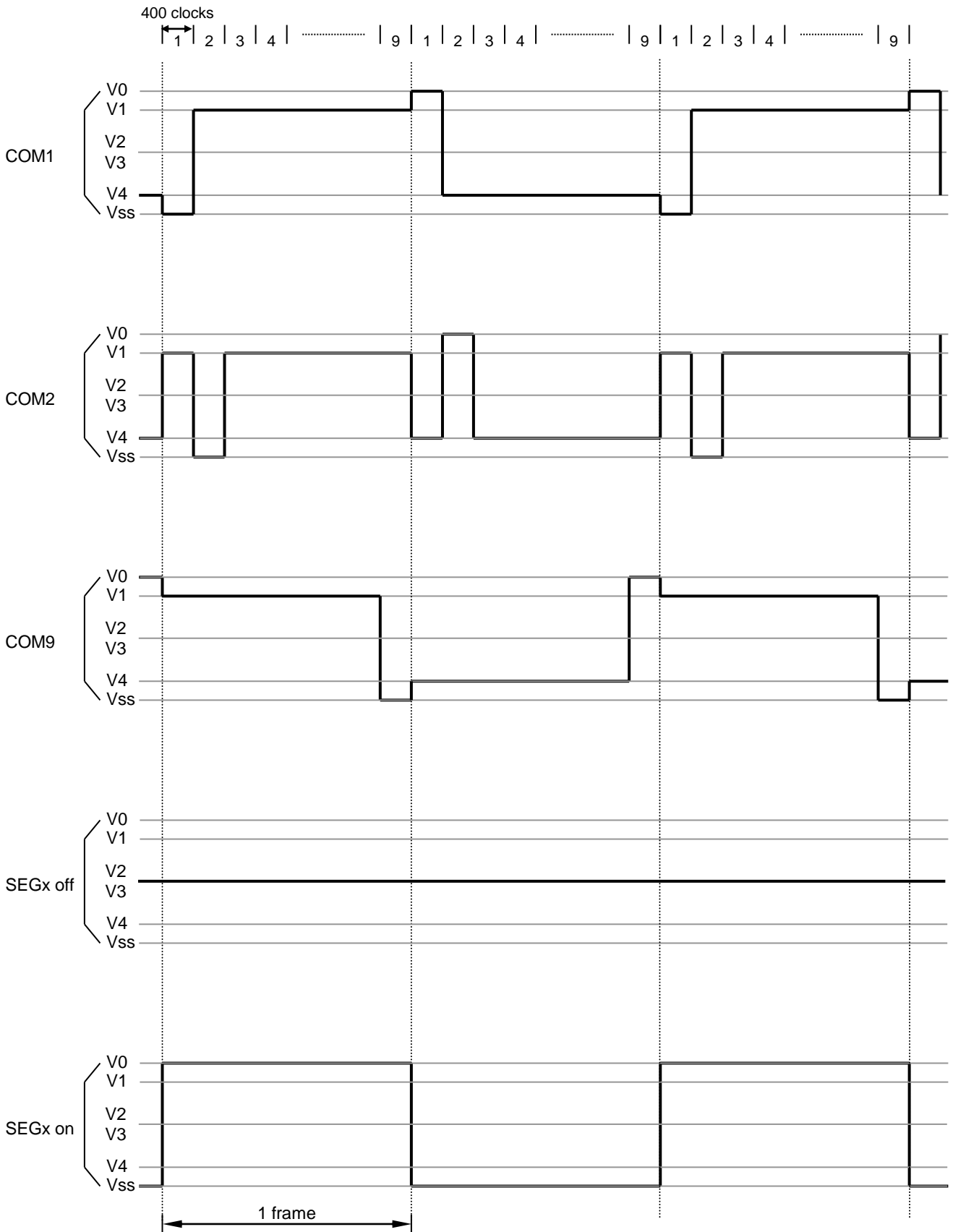

I/O Pad Configuration

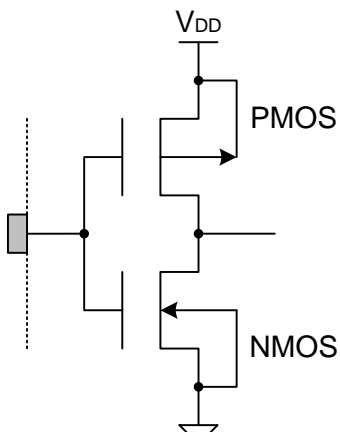

Input PAD (No Pull-Up)

XRESET, E, RS, R/W,
CSB, PSB, OPFx, OPRx,
SHLx, CLS, EXT, PSI2B

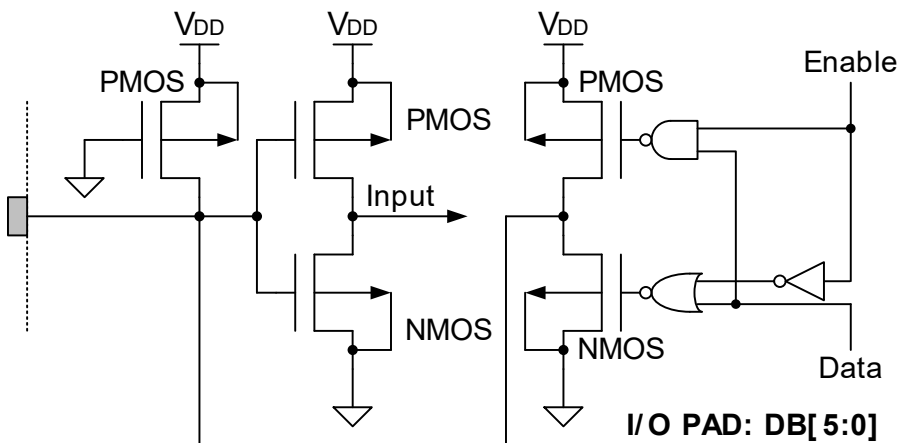

I/O PAD: DB[5:0]

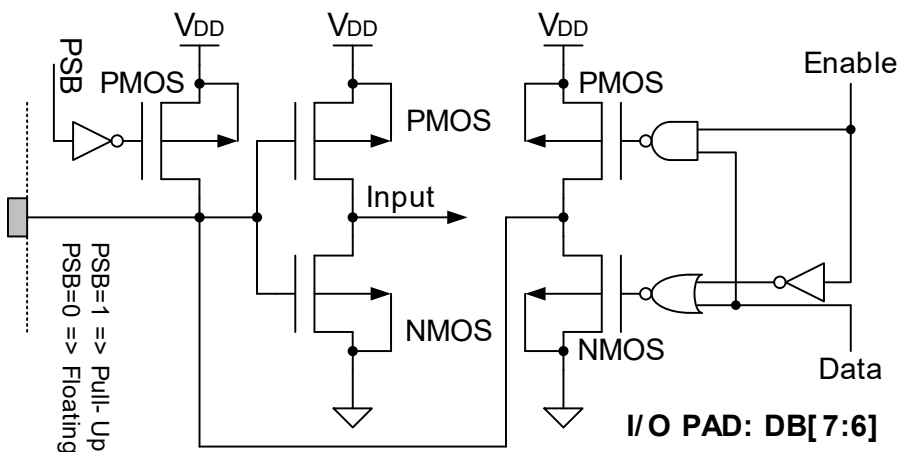

PSB=1 => Pull-Up
PSB=0 => Floating

I/O PAD: DB[7:6]

■ LCD and ST7032 Connection

SHLC/SHLS ITO option pin can select at different direction for LCD panel

- Com normal direction/Seg normal direction



2Line x 16 Characters,SHLC=1,SHLS=1

- Com normal direction/Seg reverse direction



2Line x 16 Characters,SHLC=1,SHLS=0

- Com reverse direction/Seg normal direction



2Line x 16Characters,SHLC=0,SHLS=1

- Com reverse direction/Seg reverse direction



2Line x 16Characters,SHLC=0,SHLS=0

■ **Application Circuit(ST7066U normal mode)**

- Use internal resistor(9.6K ohm) and contrast adjust with external VR.
- Booster always off.
- Has 240 character of CGROM and 8 characters of CGRAM
- Internal oscillator.

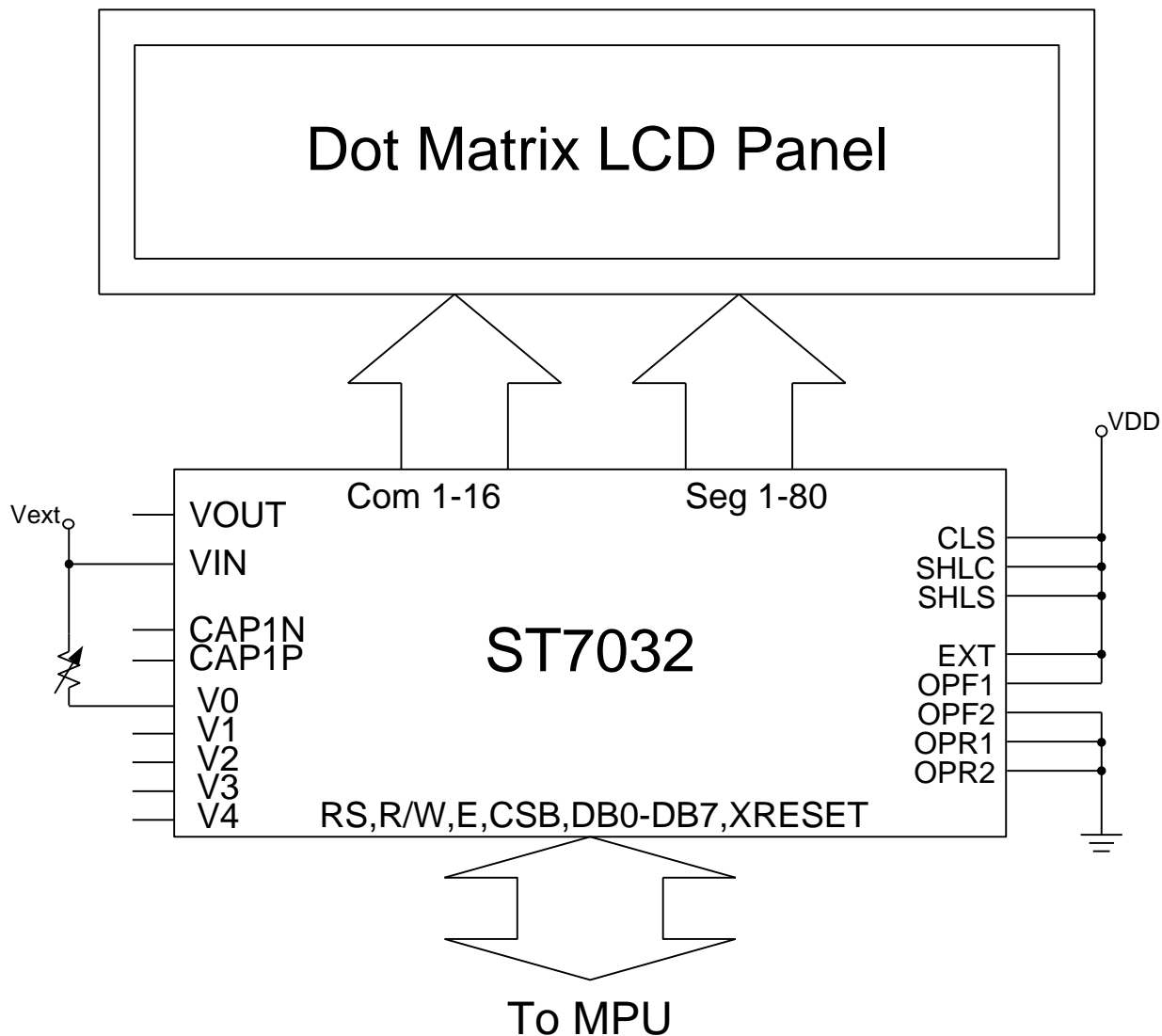

■ **Application Circuit(Extension mode)**

- Use internal follower circuit.
- Booster has 2 times pump.
- Has 240 character of CGROM and 8 characters of CGRAM
- Internal oscillator

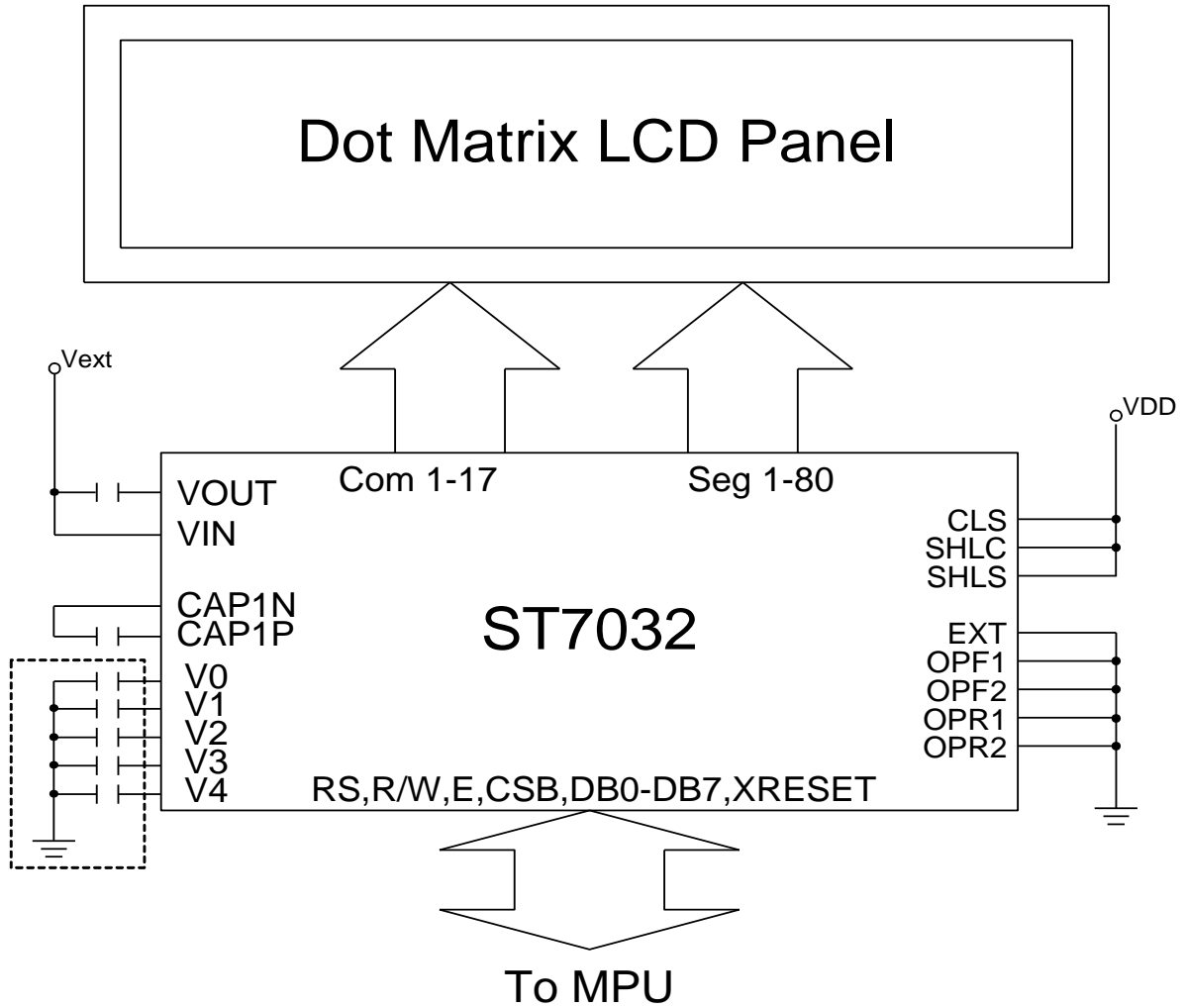

- When the heavy load is applied, the dotted line part could be added.

Application Circuit(for glass layout)

- ST7032 over Glass,6800 serial 8bit interface, with booster and follower circuit on

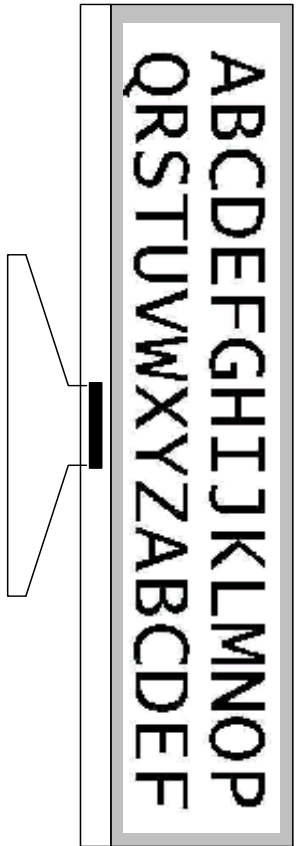

ST7032 over Glass

Pin connection:

- EXT=0
- OPR1=0
- OPR2=0
- SHLC=0
- SHLS=1
- OPF1=0
- OPF2=0
- CLS=1
- 6800 serial 8bit interface
- Vout=VIN(max 3.5V) x 2
- C1 connect 0.1uf~1uf(SMD)
- C2 connect 0.47uf~2.2uf(SMD)

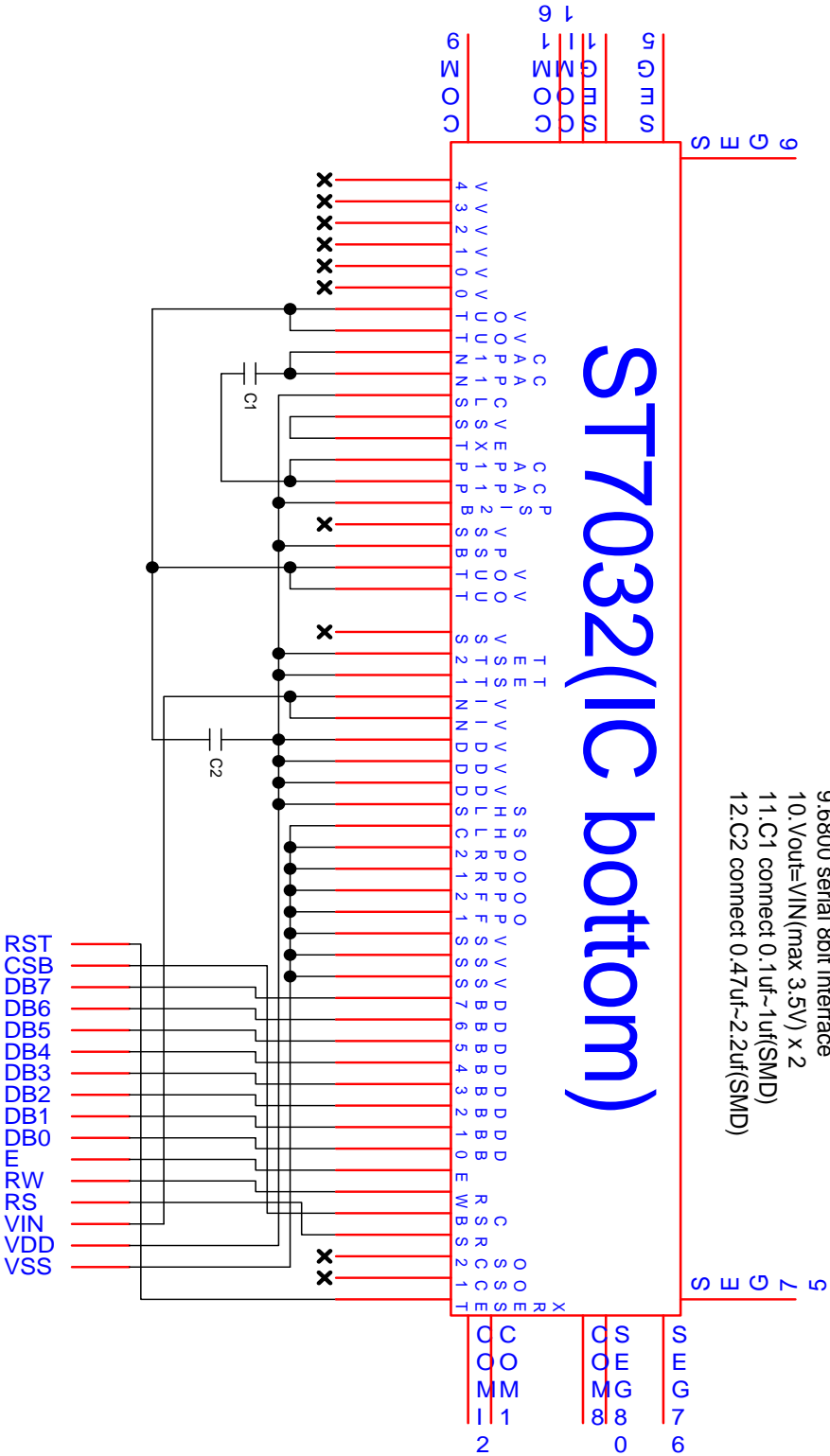

- ST7032 over Glass, 6800 serial 4bit interface, with booster and follower circuit on

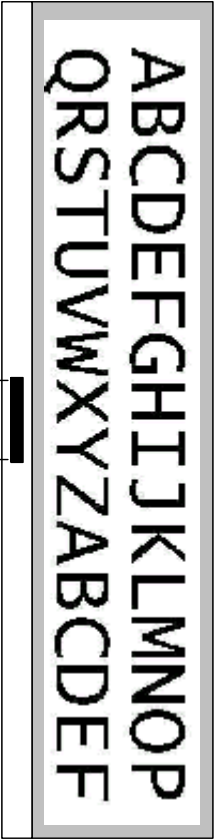

ST7032 over Glass

Pin connection:

- EXT=0
- OPR1=0
- OPR2=0
- SHLC=0
- SHLS=1
- OPF1=0
- OPF2=0
- CLS=1
- 6800 serial 4bit interface
- Vout=VIN(max 3.5V) x 2
- C1 connect 0.1uf~1uf(SMD)
- C2 connect 0.47uf~2.2uf(SMD)

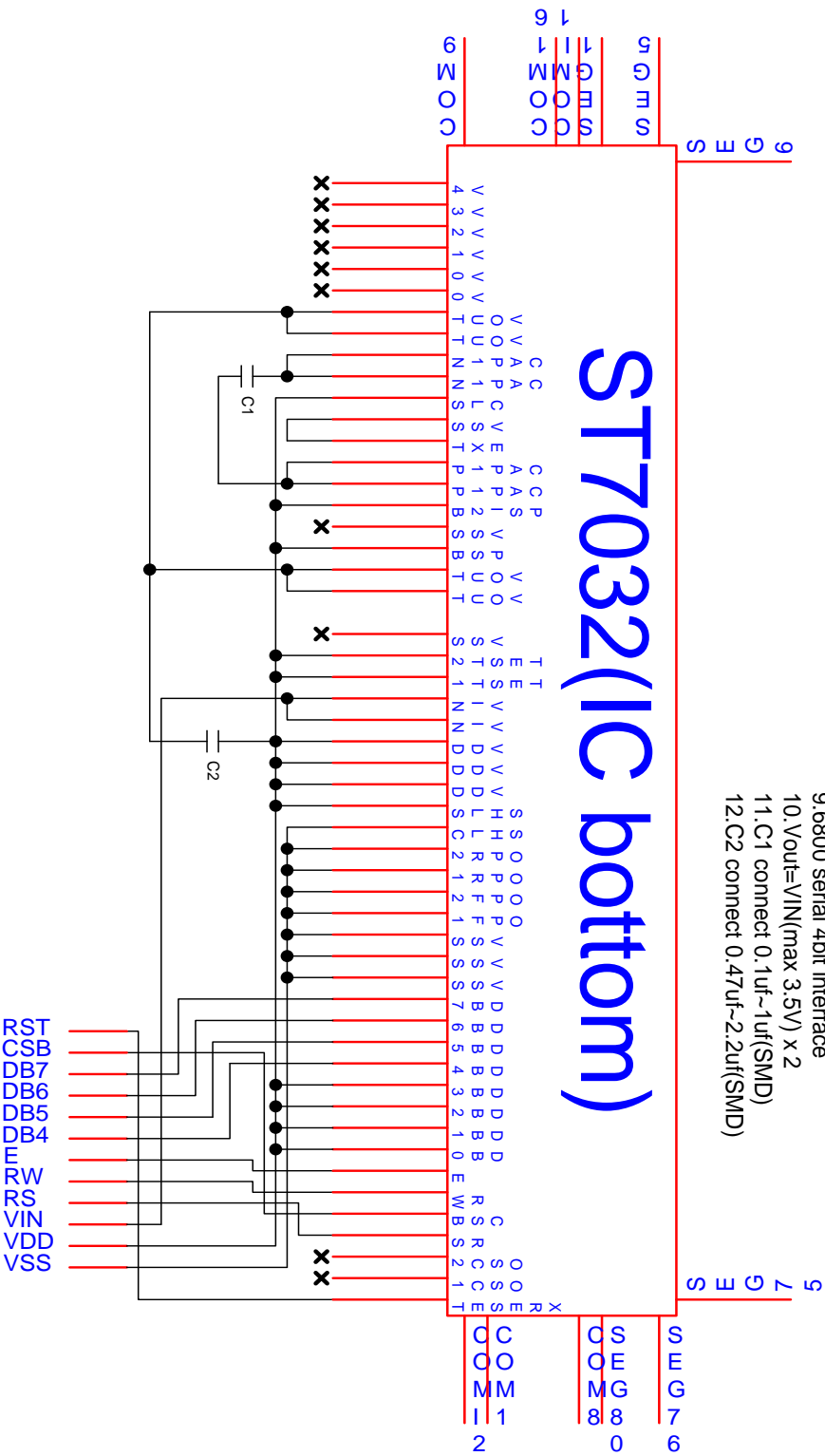

- ST7032 under Glass, serial interface, with booster and follower circuit on

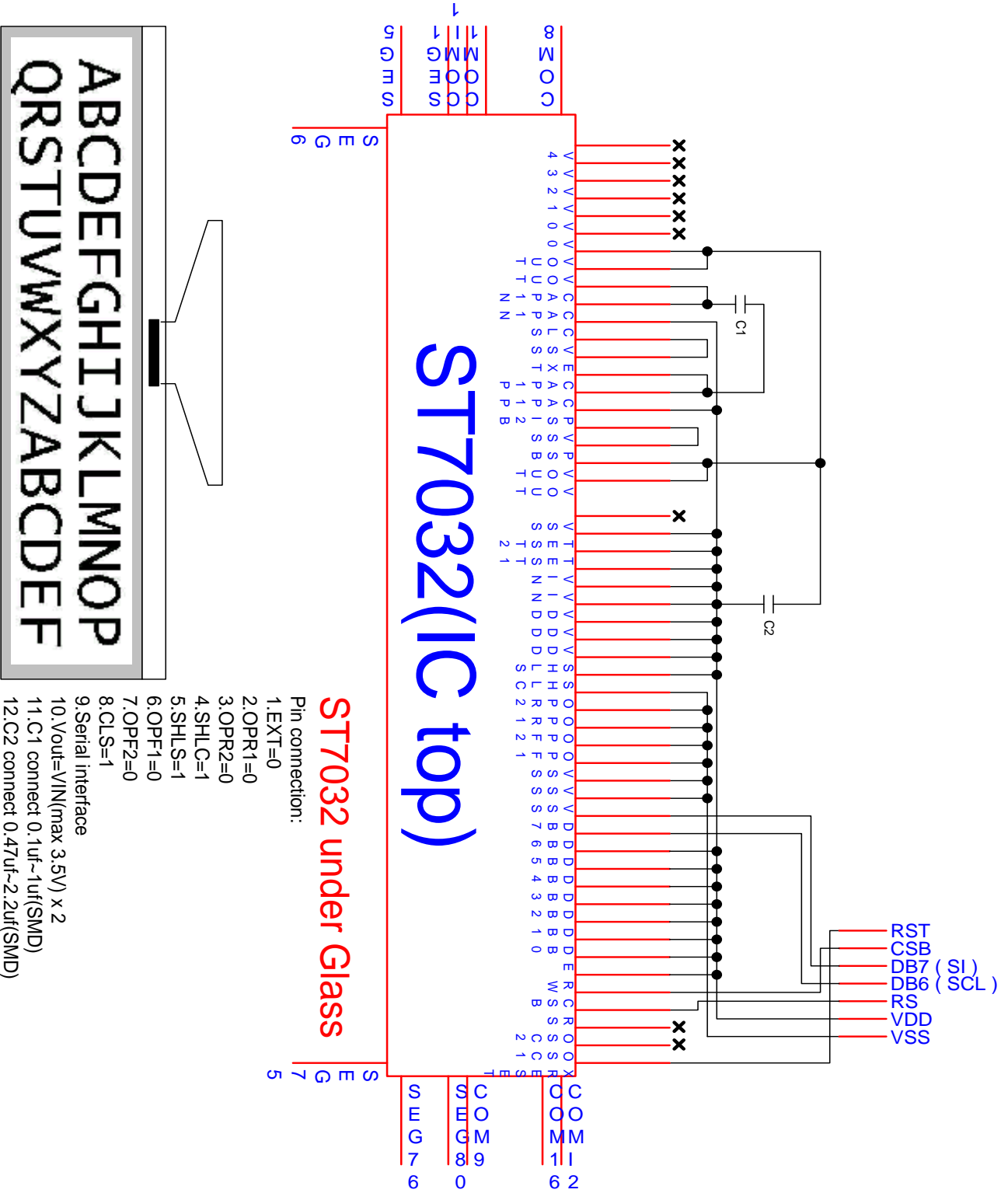

- ST7032i under Glass, IIC interface, with booster and follower circuit on

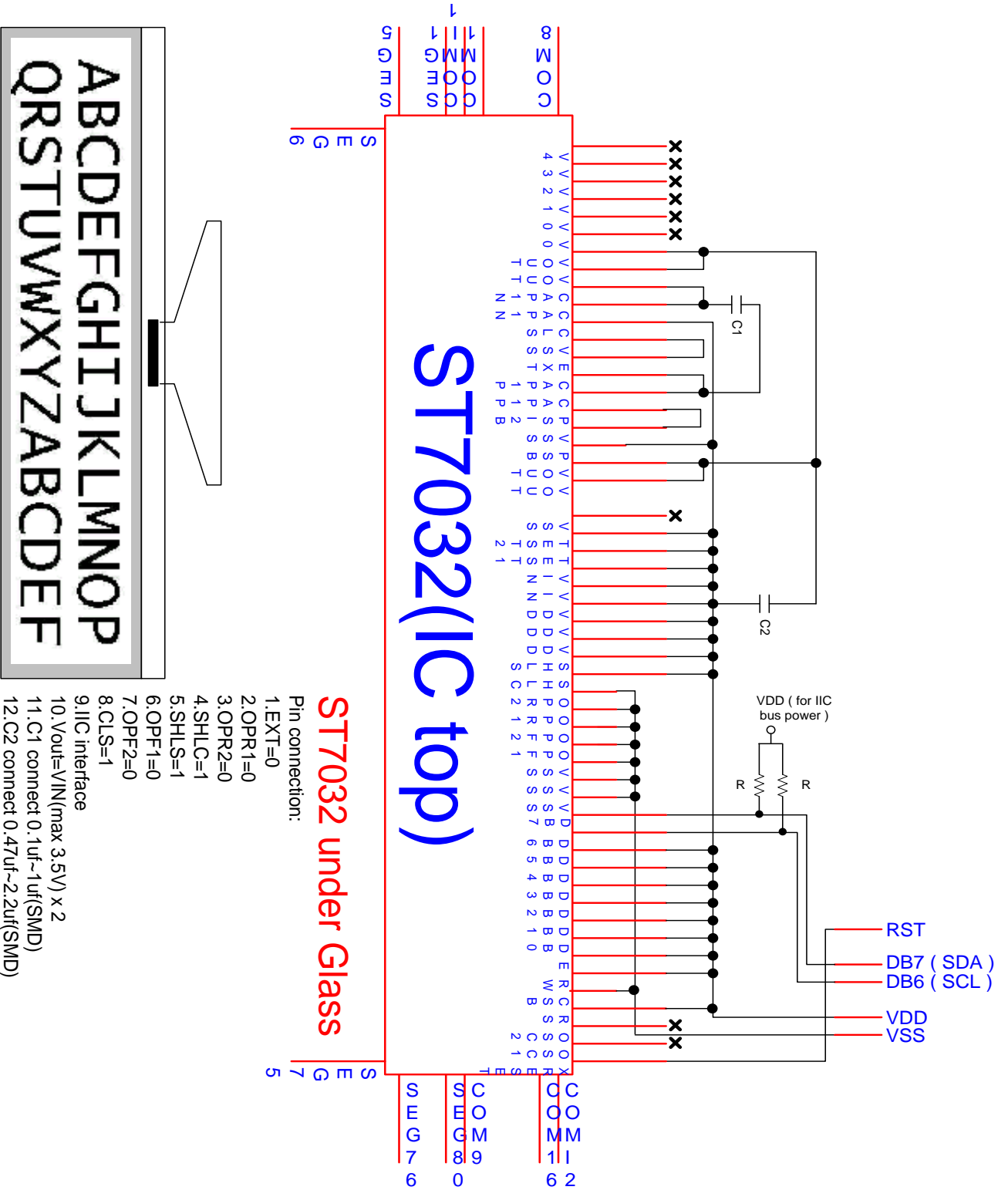

Table A1. Correspondence between Character Codes and Character Patterns
ST7032-0D (ITO option OPR1=1, OPR2=1)

b7-b4 b3-b0	0000	0001	0010	0011	0100	0101	0110	0111	1000	1001	1010	1011	1100	1101	1110	1111
0000	0	1	2	3	4	5	6	7	8	9	.	/	:	;	<	=
0001	J	T	!	l	A	0	a	9	0	e	a	7	F	4	3	
0010	o	s	"	z	B	R	b	n	e	E	T	f	U	X	6	*
0011	P	n	#	3	C	S	c	s	6	6	l	0	T	E	0	
0100	q	m	*	4	D	T	d	t	6	6	v	1	H	R	0	
0101	f	a	%	5	E	U	e	u	6	6	.	r	6	1	6	0
0110	k	0	@	6	F	V	f	v	6	0	7	n	2	3	*	U
0111	*	A	^	7	G	W	g	w	6	0	7	#	X	7	R	X
1000	6	E	C	8	H	X	h	x	6	9	4	0	8	U	6	*
1001	m	n	>	9	I	Y	i	y	6	0	6	7	J	l	1	2
1010	n	z	*	0	J	Z	j	z	6	0	6	m	N	U	6	2
1011	L	P	+	1	K	L	k	l	1	R	*	7	E	0	6	*
1100	U	0	.	2	L	M	l	l	1	R	*	0	0	0	0	*
1101	.	V	-	=	N	O	n	o	1	6	a	X	6	0	6	*
1110	0	0	.	>	N	O	n	o	1	6	a	X	6	0	6	*
1111	0	0	/	?	O		o	e	6	6	0	U	0	6	0	

Table A2. Select display pattern in CGRAM or CGROM (use OPR1, OPR2)

b7-b4 b3-b0	0000	0001	...	b7-b4 b3-b0	0000	0001	...	b7-b4 b3-b0	0000	0001	...	b7-b4 b3-b0	0000	0001	...
	0000		...		0000		...		0000		...		0000		...
	0001		...		0001		...		0001		...		0001		...
	0010		...		0010		...		0010		...		0010		...
	0011		...		0011		...		0011		...		0011		...
	0100		...		0100		...		0100		...		0100		...
	0101		...		0101		...		0101		...		0101		...
	0110		...		0110		...		0110		...		0110		...
	0111		...		0111		...		0111		...		0111		...
	1000		...		1000		...		1000		...		1000		...
	1001		...		1001		...		1001		...		1001		...
	1010		...		1010		...		1010		...		1010		...
	1011		...		1011		...		1011		...		1011		...
	1100		...		1100		...		1100		...		1100		...
	1101		...		1101		...		1101		...		1101		...
	1110		...		1110		...		1110		...		1110		...
	1111		...		1111		...		1111		...		1111		...

OPR2,OPR1=(0,0) OPR2,OPR1=(0,1) OPR2,OPR1=(1,0) OPR2,OPR1=(1,1)

Table A3. Correspondence between Character Codes and Character Patterns

ST7032-0F

b7-b4 b3-b0	0000	0001	0010	0011	0100	0101	0110	0111	1000	1001	1010	1011	1100	1101	1110	1111
0000	CG RAM (1)															
0001	(2)															
0010	(3)															
0011	(4)															
0100	(5)															
0101	(6)															
0110	(7)															
0111	(8)															
1000	(1)															
1001	(2)															
1010	(3)															
1011	(4)															
1100	(5)															
1101	(6)															
1110	(7)															
1111	(8)															

Table A4. Select display pattern in CGRAM or CGROM (use OPR1, OPR2)

b7-b4 b3-b0	0000	0001	...	b7-b4 b3-b0	0000	0001	...	b7-b4 b3-b0	0000	0001	...	b7-b4 b3-b0	0000	0001	...	
0000	Replaced By CGRAM Pattern		...	0000	Replaced By CGRAM Pattern		...	0000	Replaced By CGRAM Pattern		...	0000	CG RAM (1)		...	
0001			...	0001			...	0001			...	0001	(2)		...	
0010			...	0010			...	0010			...	0010	(3)		...	
0011			...	0011			...	0011			...	0011	(4)		...	
0100			...	0100			...	0100			...	0100	(5)		...	
0101			...	0101			...	0101			...	0101	(6)		...	
0110			...	0110			...	0110		(7)		...	0110	(7)		...
0111			...	0111			...	0111		(8)		...	0111	(8)		...
1000		Replaced By CGRAM Pattern		...		1000	(1)			...	1000	(1)		...	1000	(1)
1001			...	1001	(2)		...	1001	(2)		...	1001	(2)		...	
1010			...	1010	(3)		...	1010	(3)		...	1010	(3)		...	
1011			...	1011	(4)		...	1011	(4)		...	1011	(4)		...	
1100			...	1100	(5)		...	1100	(5)		...	1100	(5)		...	
1101			...	1101	(6)		...	1101	(6)		...	1101	(6)		...	
1110			...	1110	(7)		...	1110	(7)		...	1110	(7)		...	
1111			...	1111	(8)		...	1111	(8)		...	1111	(8)		...	

OPR2,OPR1=(0,0)

OPR2,OPR1=(0,1)

OPR2,OPR1=(1,0)

OPR2,OPR1=(1,1)